



CHUGACH
POWERING ALASKA'S FUTURE



Electric Service Requirements 2015 Edition

CHUGACH ELECTRIC ASSOCIATION, INC.
Anchorage, Alaska
May 9, 2023

TO: Victor Fosberg, Lead Electrical Inspector, MOA Development Services

THROUGH: Mike Miller, VP, Engineering 

FROM: William Ryan, Planning and Standards EIT 

SUBJECT: **Amendment & Clarification to 2015 Electric Service Requirements – Regarding Residential Service Disconnects, Farm Panels, and Approved Equipment Lists**

In response to changes in the 2020 National Electrical Code (NEC) and local amendments adopted by the Municipality of Anchorage (MOA), Chugach Electrical Association, Inc. (Chugach) is issuing the following amendments and clarifications to the Electric Service Requirements 2015 Edition (ESR). These changes are effective to the publication date shown on this memo.

1. Delete ESR Appendices (pages 202 – 209) “Service Equipment Quick Reference Guides”. Chugach does not maintain a list of approved service equipment. New, modified, or replaced service equipment must meet the requirements of the NEC and ESR as written and amended.
2. Rescind all previous memos and communications from Chugach and Municipal Light & Power (ML&P) regarding approved lists of service equipment and approvals of individual equipment that do not conform with the ESR. New, modified, or replaced service equipment must meet the requirements of the NEC and ESR as written and amended.
3. Replace ESR Section 306.2(d) with the following language “A circuit breaker or switch shall not be used as a meter disconnect or main service disconnect within a “Main Distribution Panel” (MDP) other than a switchboard service section.”
4. Delete ESR Section 306.7(1)
5. Replace ESR Sections 307.29 and 601.13 with the following language “Self-contained metering panels shall not contain bus space for more than 4 two-pole (phase to phase) branch circuit breakers on the load side of the meter disconnect.”

NEW SERVICE PROCEDURE CHECKLIST

The following represents a checklist of the basic procedures required to complete the Utility service application. Please consult the checklist below to make certain all the applicable items have been completed.

1. **Electrical Service Extension Request:** For ML&P service, complete the ML&P Electrical Service Extension Request form; this is the first step in upgrading or installing a service. The extension request form is available on the ML&P web site www.mlandp.com/redesign/new_construction.htm. The extension request can be filled out and submitted to ML&P online. The Electrical Service Extension Request requires a signature page to be completed and sent to ML&P's Line Extension Coordinator (See Directory) for processing. It can also be faxed, E-mailed, or mailed; or you may fill one out in person at the main administration office.

For Chugach service, the building owner, or authorized representative must complete the Application for Service (residential and business application forms are available at www.chugachelectric.com) and bring it to Member Services at 5601 Electron Drive between the hours of 8:00 a.m. to 5:00 p.m., Monday through Friday.

2. **Service Location:** You must provide to the Utility: 1) a site plan showing the proposed service location and location of other utilities; 2) the building outline; 3) any future building(s); 4) the property layout and site elevations; and 5) landscaping plans.
3. **Electrical Drawings:** For all commercial services and residential services over eight (8) units, you must provide the Utility with a complete set of MOA approved electrical drawings which include service entrance equipment and distribution panel information. Outside of the MOA inspection area, MOA approvals do not apply.
4. **Load Estimates:** For all services, you must provide the Utility with an estimate of the electrical demand load, based on the total connected load. Commercial services will require the electrical load information as furnished by the customer's engineer and approved by the MOA. Outside of the MOA inspection area, MOA approvals do not apply.

Once the above items are completed, the Utility can begin the necessary design.

5. **Permit and Inspection:** Contact the Municipality of Anchorage Development Services Department (See Directory) for procedures on obtaining the required permit and electrical inspection of your service entrance equipment. Outside of the MOA inspection area, contact the State of Alaska for inspection of non-residential and multi-family residential larger than duplexes.
6. **New Accounts:** You must establish an account with the Utility through the Customer Service Department (See Directory) for each new meter.
7. **Payments and Fees:** If required, it may be necessary to pay a deposit or fee to the Utility for such items as temporary services, trenching, concrete cutting and repair, and steam thawing.
8. **Construction Schedule:** Contact the Utility's Line Extension or Project Coordinator (See Directory) after the service entrance has been inspected for scheduling information.

Once items five through eight have been completed, the Utility crews can begin service construction.

**MUNICIPAL LIGHT & POWER
and
CHUGACH ELECTRIC ASSOCIATION**

ELECTRIC SERVICE REQUIREMENTS

**INFORMATION FOR USE BY CUSTOMERS,
ARCHITECTS, ENGINEERS, CONTRACTORS,
ELECTRICIANS, AND THOSE ENGAGED IN THE
PLANNING AND CONSTRUCTION OF
ELECTRIC SERVICE AND METER INSTALLATIONS**

**2015 EDITION
(Revised 6/2015)**

This book is also available on the utility websites:

www.mlandp.com under the "New Construction" tab

*www.chugachelectric.com under the Customer Service tab
"For Your Home" or "For Your Business"*

INTRODUCTION

Municipal Light & Power (ML&P) and Chugach Electric Association (Chugach) assembled this book to assist customers, architects, engineers, and electrical contractors in planning for and obtaining electric service to new or remodeled installations.

The information presented is intended to supplement the requirements of the National Electrical Code and all other applicable federal, state, and municipal codes, regulations, and ordinances.

This 2015 edition of the Electric Service Requirements book supersedes all previous editions and revisions.

ML&P and Chugach strive to serve their customers promptly and satisfactorily by enhancing the electric service connection process and will gladly give attention to any questions regarding the requirements in this book.

Mark Johnston
Acting General Manager
Municipal Light & Power

Bradley Evans
Chief Executive Officer
Chugach Electric Association

MUNICIPAL LIGHT & POWER DEPARTMENT DIRECTORY

1200 East 1st Avenue
Anchorage, Alaska 99501
(907) 279-7671 (24 hrs)

Line Extension Coordinator (new service applications)
7:30 a.m. to 4:00 p.m., Monday through Friday
(907) 263-5212

Customer Service Division (billing and account information)
8:00 a.m. to 5:30 p.m., Monday through Friday
(907) 263-5340

Engineering Division
7:00 a.m. to 3:30 p.m., Monday through Friday
(907) 263-5228 or (907) 263-5229

Operations Division
7:00 a.m. to 3:30 p.m., Monday through Friday
(907) 263-5279

Metering Section
7:00 a.m. to 3:30 p.m., Monday through Friday
(907) 263-5252

CHUGACH ELECTRIC ASSOCIATION DEPARTMENT DIRECTORY

Street Address: 5601 Electron Drive, Anchorage, AK 99518
Mailing Address: P.O. Box 196300, Anchorage, AK 99519-6300
www.chugachelectric.com
Telephone (907) 563-7494
Toll Free Number (800) 478-7494
8:00 a.m. - 5:00 p.m., Monday through Friday

Member Services/Customer Service

Residential and commercial connects, disconnects, new services, account information, billing and payment options, capital credits, information, new applications and other customer services
Lobby Hours, 8:00 a.m. - 5:00 p.m., Monday through Friday
(907) 563-7366

Credits and Collections:

8:00 a.m. - 5:00 p.m., Monday through Friday
(907) 563-5060

Engineering Department

8:00 a.m. - 5:00 p.m., Monday through Friday
(907) 762-4453 or Fax (907) 762-4693

Engineering Project Coordinator

Extension of new primary electric facilities to customer's property (for facilities requiring more than a service hook-up)
8:00 a.m. - 5:00 p.m., Monday through Friday
(907) 762-4631

CHUGACH ELECTRIC ASSOCIATION DEPARTMENT DIRECTORY

Land Services

Easements, encroachments, plat review

8:00 a.m. - 5:00 p.m., Monday through Friday

(907) 762-4781

Construction & Maintenance

Electric facility clearance- information, meter base locations, repairs, relocates, removals or upgrades, over-sized load moves, field disconnects, and damage done by Chugach crews

8:00 a.m. - 4:30 p.m., Monday through Friday

(907) 762-4370 or (907) 762-7655

Outage Hot Line

8:00 a.m. - 5:00 p.m., Monday through Friday

(907) 762-7888

(800) 478-7494 After-Hours

Power Theft Hot Line

(907) 762-4731

Danger Tree Hot Line

(907) 762-7227 (24-Hour Voice Mail Message Box)

ADDITIONAL IMPORTANT TELEPHONE NUMBERS

Municipality of Anchorage, Development Services, Building Safety:

General Information and Permits	343-8211
To request an inspection for a project with a permit	343-8300
To fax a request for an inspection for a project with a permit	249-7777
Inspection Help Line	343-8300
Lead Electrical Inspector	343-8316

Alaska Digline - Anchorage and Statewide: 811

The Alaska Digline will notify the following:

Aircraft Services International Group
Alaska Communications AC
Alaska DOT/PF Anchorage Street Lights
Alaska Fiber Star
Alaska Native Medical Center
Alaska Railroad Corp.
Alyeska Pipeline Co.
Anchorage School District
Anchorage Water & Wastewater
AT&T Alascom
Aurora Gas LLC
Chugach Electric Association
ConocoPhillips Alaska, Inc.
Cook Inlet Pipeline Co.

Doyon Utilities, LLC
ENSTAR Natural Gas
GCI - General Communication
Hilcorp Alaska LLC
JBER – Port of Anchorage
Matanuska Telephone Assn.
MOA Signal & Street Maintenance
Municipal Light & Power
Port of Anchorage
Ted Stevens International Airport
TelAlaska Inc.
Tesoro Alaska
United Utilities, Inc.

SERVICE AREAS ANCHORAGE BOWL

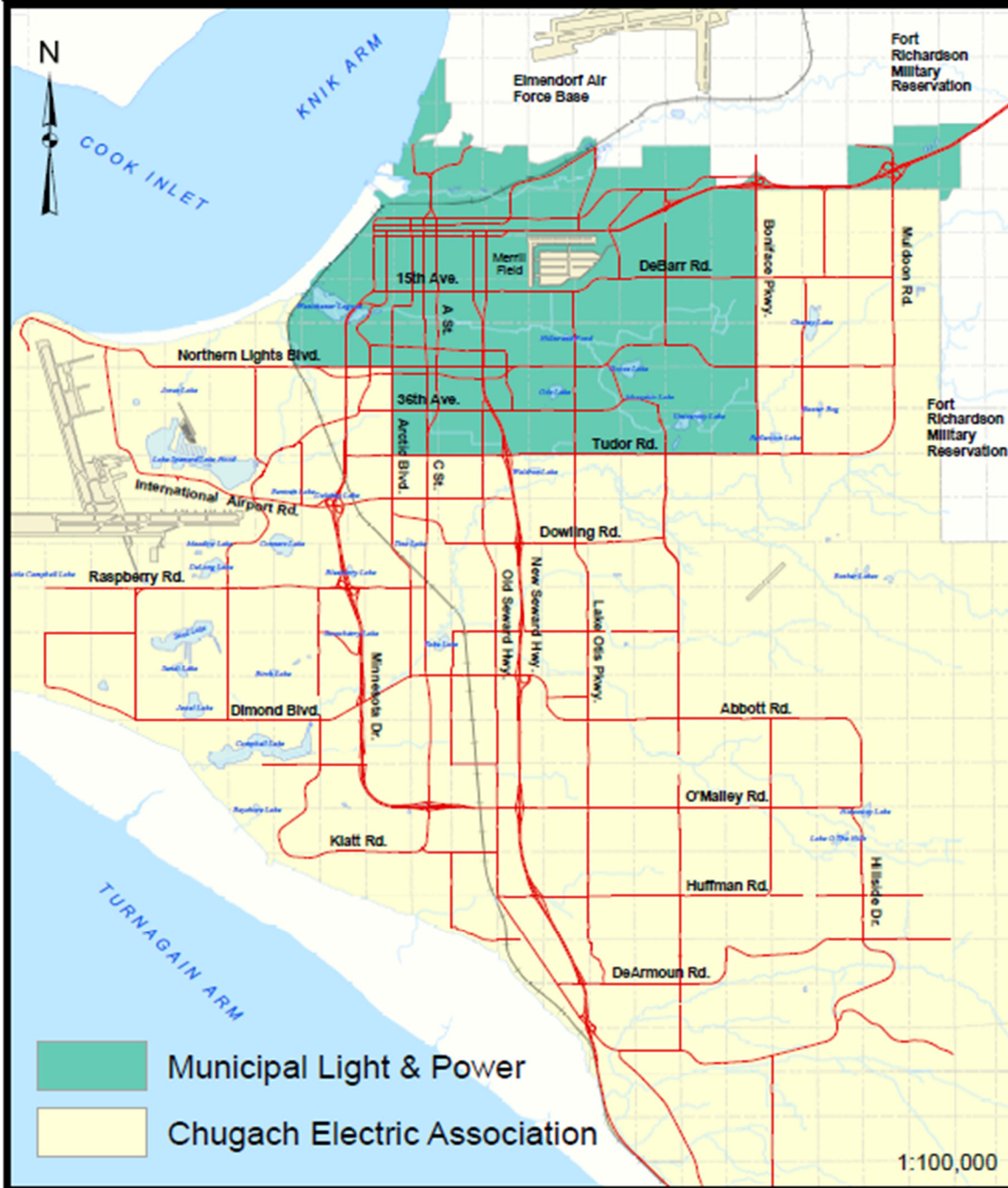

CHUGACH SERVICE AREA OUTSIDE ANCHORAGE BOWL

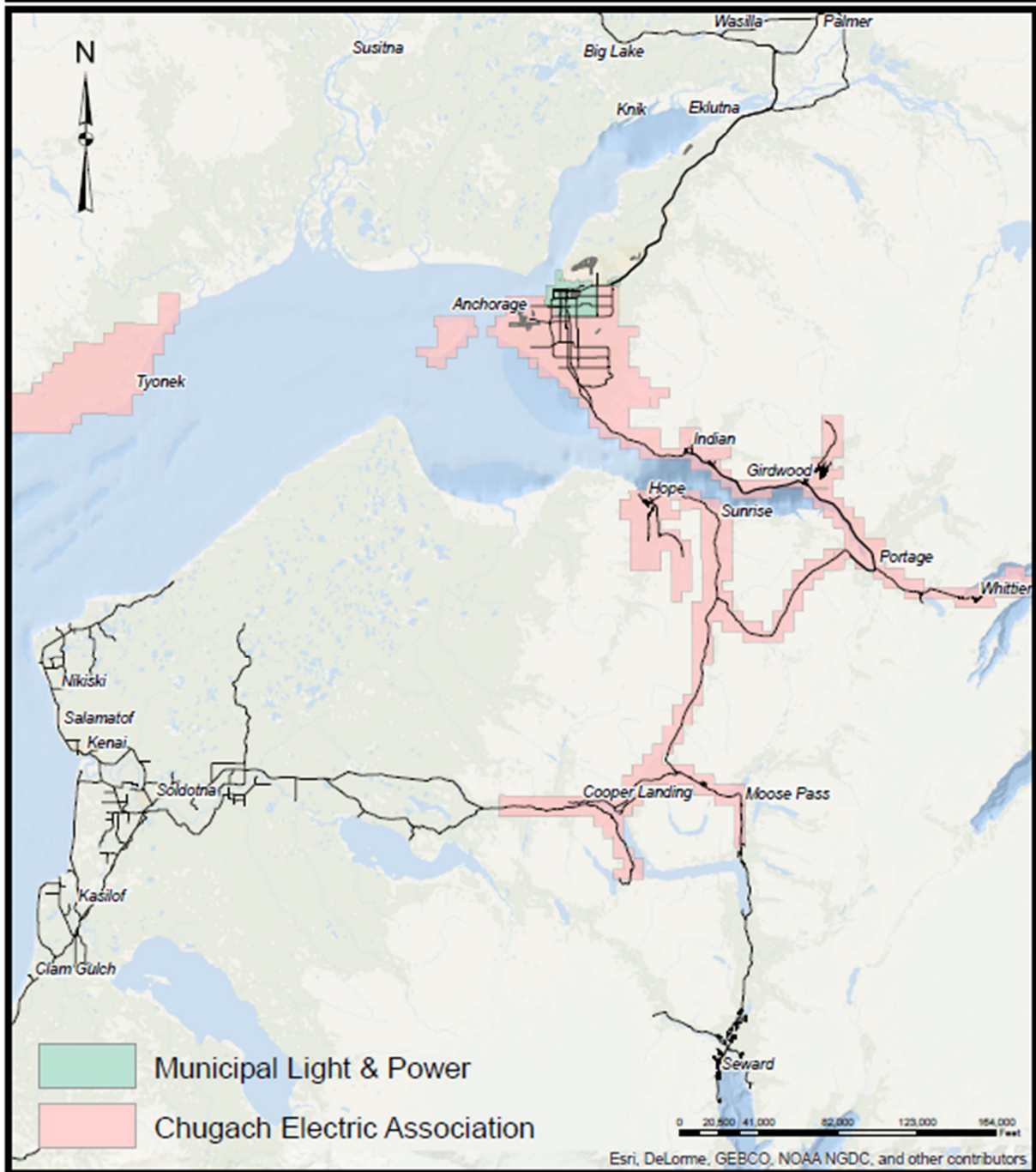

Table of Contents

SECTION 100 – GENERAL INFORMATION	1
101 Purpose	1
102 Changes in Requirements.....	1
103 Utility Service Area	1
104 Codes and Ordinances	1
105 Disconnection.....	2
106 Service Complaints	2
107 Coordination Responsibilities.....	2
SECTION 200 - SERVICE	3
201 Character of Service.....	3
202 Types of Service.....	3
203 Application for Service	4
204 Service Feasibility.....	5
205 Electric Service Extensions to Permanent Facilities.....	6
206 Electric Service Extensions to Temporary Facilities.....	7
207 Easements.....	8
208 Customer Facilities.....	8
209 Service Conductor Connection.....	9
210 Service Facilities on Customer's Premises.....	10
211 Undesirable Service Characteristics	11
212 Electrical Generators and Transfer Equipment.....	11
213 Customer Sub-Metering for Resale of Electricity.....	13
214 Interconnection and NET Metering	13
SECTION 300 – METERING AND SERVICE EQUIPMENT.....	14
301 Scope	14
302 Metering and Service Equipment Location	15

303	Metering and Service Equipment Requirements, General	18
304	Grounding and Bonding Requirements.....	23
305	Sealing and Locking Requirements.....	24
306	Service and Meter Disconnect Requirements	25
307	Self-Contained Metering Requirements, General.....	31
308	Multiple Metering Requirements, General.....	33
308	Multiple Metering Requirements, General.....	34
309	CT Rated Metering Requirements, General.....	37
309	CT Rated Metering Requirements, General.....	38
310	Switchboard Service Section Requirements, General	42
311	High Voltage (Primary) Metering Requirements, General	46
312	Load Control and Pulse Metering	47
313	Meter Testing.....	47
314	Fire Alarm and Fire Pump Equipment.....	48
315	Unusual Conditions.....	48
SECTION 400 – INSPECTIONS		50
401	General Information.....	50
402	Electric Service Inspection Requirements	50
403	How and When to Call for Inspection.....	50
SECTION 500 - INSTALLATION GUIDELINES & SPECIFICATIONS.....		52
501	Overhead Services to Buildings or Structures.....	52
502	Overhead Services Attached to Poles	56
503	Overhead Temporary Construction Service	60
504	Overhead Conductor Clearances.....	64
505	Underground Temporary Construction Service.....	66
506	Underground Service, Wall-Mounted, Up To 200 Amps	68
507	Underground Service, Post-Mounted, Up To 800 Amps.....	70
508	Commercial Hinged-Top Service Pedestal.....	74

509	Multiple Metering, Residential, 6-Meter Maximum	78
510-A	Multiple Metering, Commercial, 6-Meter Maximum, Modular	82
510-B	Multiple Metering, Commercial, 6-Meter Maximum, Top-Bussed	86
511	Multiple Metering, Self-Contained and CT Rated	90
512	Multiple Metering, Wall-Mounted Style, 7-Meter Minimum	94
513	Multiple Metering, Switchboard Style, 7-Meter Minimum	98
514	Single-Phase CT Service, Wall-Mounted, 201 Amps to 800 Amps.....	102
515	Three-Phase CT Service, Wall-Mounted, 201 Amps to 800 Amps.....	106
516	Three-Phase CT Service, Wall-Mounted, 801 Amps to 2,500 Amps.....	110
517	Switchboard Service Sections, 201 Amps to 4,000 Amps.....	116
518	Emergency/Standby Systems (Generators).....	120
519	Meter Socket Connection Diagrams.....	124
520	Service Riser Conduit Requirements.....	126
521	Working Space and Clearance Requirements.....	130
SECTION 600 - SERVICE EQUIPMENT SPECIFICATIONS.....		132
601	Residential Combination Meter Panel and Service Disconnect	132
602	Combination Safety Socket Panel with Test-Block Bypass and Service Disconnect.....	134
603	Self-Contained Meters Installed in Switchboards.....	138
604	Commercial Hinged-Top Service Pedestal.....	142
605	CT Rated Meter Socket	146
606	Combination Residential Multi-Meter Panels, 6-Meter Maximum.....	148
607	Clearances for Residential Multi-Metering Installations.....	150
608	Combination Disconnect Device and Terminating Enclosure.....	152
609	Wall-Mounted Pull Box with Terminating Facilities.....	154
610	Single-Phase CT Mounting Base.....	156
611	Single-Phase CT Mounting Base with Integral Lugs.....	160
612	Three-Phase CT Mounting Base.....	162
613	Three-Phase CT Mounting Base with Integral Lugs.....	166

614	CT Cabinet, Wall-Mounted, 201 Amps to 800 Amps	168
615	CT Cabinet, Wall-Mounted, 801 Amps to 2,500 Amps	170
616	Standard Switchboard Service Section with CT Compartment.....	174
617	Standard Switchboard Service Section with CT Compartment and Filler Panel.....	176
618	Switchboard Service Section 15-inch Hinged Meter Panel	178
619	Outdoor Enclosures for Switchboards	180
620	CT Compartment for Switchboards, 201 Amps to 1,000 Amps	182
621	CT Compartment for Switchboards, 1,001 Amps to 3,000 Amps	184
622	CT Compartment for Switchboards, 3,001 Amps to 4,000 Amps	186
623	Removable Bus Link and CT Support with 4-inch Bus.....	188
624	Removable Bus Link and CT Support with 5-inch Bus.....	190
625	Combination Switchboard Service Section and Pull Section.....	192
626	Underground Service Termination - Switchboard Service Section	194
627	Underground Service Terminating Facilities in Pull Boxes or Pull Sections.....	196
SECTION 700 - PAD MOUNT TRANSFORMER SPECIFICATIONS		200
700	ML&P Construction Standard EC11	200
APPENDICES		202
Meter Socket Quick Reference Guide - Self-Contained Single-Phase		202
For all Underground Residential Services rated up to 100 amps.....		202
For all Underground Residential Services rated up to 200 amps.....		203
For all Commercial, Industrial, and Non-Residential Services.....		204
For All Services Rated 201 Amps and Above.....		207
CT Cabinet Quick Reference Guide - Single-Phase		208
CT Cabinet Quick Reference Guide - Three-Phase		209
Glossary		210
EUSERC/ELECTRONIC SERVICE REQUIREMENTS DRAWING CROSS REFERENCE		218
INDEX.....		219

Service Installation Summary

Following is a list of service configurations and the corresponding sections of this book that are most applicable. This service installation summary is not comprehensive and all applicable requirements and specifications from other sections of this book remain in effect for all service projects.

Overhead Service, Temporary, Single Meter

Section 302	Section 601 - Residential
Section 303	Section 602 - Commercial
Section 503	

Overhead Service, Permanent, Single Meter

Section 302	Section 502
Section 303	Section 601 - Residential
Section 501	Section 602 - Commercial

Underground Service, Temporary, Single Meter

Section 302	Section 520
Section 303	Section 601 - Residential
Section 505	Section 602 - Commercial

Underground Service, Permanent, Single Meter

Section 302	Section 520
Section 303	Section 601 - Residential
Section 506	Section 602 - Commercial

Multiple Metering, Residential, 6 Meters or Less

Section 302	Section 308	Section 606 - Residential
Section 303	Section 509	
Section 307	Section 520	

Multiple Metering, Residential, 7 Meters or More

Section 302	Section 307	Section 520
Section 303	Section 308	Section 607
Section 306	Section 512	Section 608

Multiple Metering, Commercial, 6 Meters or Less, Wall-Mounted

Section 302	Section 307	Section 510-B	Section 609
Section 303	Section 308	Section 520	
Section 306	Section 510-A	Section 602	

Service Installation Summary

Multiple Metering, Commercial, 7 Meters or More, Wall-Mounted

Section 302	Section 307	Section 520
Section 303	Section 308	Section 602
Section 306	Section 512	Section 608

Multiple Metering, Commercial, 7 Meters or More, Switchboard Style

Section 302	Section 307	Section 513	Section 625
Section 303	Section 308	Section 520	Section 626
Section 306	Section 310	Section 603	

CT Metering, Single-Phase, Wall-Mounted, 201 Amps to 800 Amps

Section 302	Section 309	Section 605
Section 303	Section 514	Section 610/611
Section 306	Section 520	Section 614

CT Metering, Three-Phase, Wall-Mounted, 201 Amps to 800 Amps

Section 302	Section 309	Section 605
Section 303	Section 515	Section 612/613
Section 306	Section 520	Section 614

CT Metering, Three-Phase, Wall-Mounted, 801 Amps to 2,500 Amps

Section 302	Section 309	Section 605
Section 303	Section 516	Section 615
Section 306	Section 520	Section 623

CT Metering, Three-Phase, Switchboard Style, 201 Amps to 4,000 Amps

Section 302	Section 310	Section 616/617	Section 620/621/622
Section 303	Section 517	Section 618	Section 623/624
Section 306	Section 520	Section 619	Section 625/626

Emergency/Standby Generators and Transfer Equipment

Section 212	Section 518
-------------	-------------

RESERVED

SECTION 100 – GENERAL INFORMATION

101 Purpose

- 101.1 The purpose of this book is to inform customers, consultants, and contractors of the requirements for obtaining electric service from the Utility. Before purchasing the equipment for a proposed installation or beginning construction, the customer and/or his representative should contact the Utility's Line Extension Coordinator to learn the general requirements for obtaining service in the most economical and feasible way.
- 101.2 This book **is not** intended to ensure the adequacy and safety of the customer's wiring and equipment; such responsibility remains with the customer. Also, the Utility does not perform the function of inspecting the customer's internal wiring for compliance with requirements of electrical codes or regulations established by public bodies. This function is within the jurisdiction of municipal and other governmental authorities. In the Chugach service area that lies outside the Municipality of Anchorage (MOA) building inspection area, Chugach performs a limited inspection to ensure that the service is safe to energize and for compliance with Chugach requirements. This limited inspection applies to residential service equipment (up to and including duplexes) where the State of Alaska doesn't provide inspection.

102 Changes in Requirements

- 102.1 The information in this book is updated and revised based on changes to codes, ordinances, and the Utility's Tariff. The information presented is also updated and revised based on changes in circumstances and experience in the application of these requirements.

103 Utility Service Area

- 103.1 ML&P and Chugach provide electric service to all residents within its service area boundaries as approved by the Regulatory Commission of Alaska (RCA) in accordance with the Utility's Tariff. Refer to the ML&P and Chugach Service Area maps on pages iv and v.

104 Codes and Ordinances

- 104.1 Construction of new or remodeled installations must conform to current and applicable provisions of the National Electrical Code (NEC), the National Electrical Safety Code (NESC), federal, state, and municipal codes, regulations and ordinances, Utility's Tariff, and the Utility's Electric Service Requirements. The Utility's personnel are not authorized to waive federal, state or municipal regulations.
- 104.2 Where there is a conflict between the Utility's Tariff and this book, the Tariff shall take precedence. Codes, ordinances, and regulations are available from several sources. The Utility's Tariffs are available for customer inspection at the Utility's office (online at: <https://www.mlandp.com/redesign/mlputilitytariff.htm> or: <http://www.chugachelectric.com/inside-chugach/regulatory-affairs>).
- 104.3 Information and/or questions about the National Electrical Code (NEC) should be directed to the Municipality of Anchorage, Development Services, Building Safety Plan Review Engineer or to the Lead Electrical Inspector.

SECTION 100 – GENERAL INFORMATION

105 Disconnection

105.1 The Utility may disconnect or discontinue service to a customer for the following reasons (see the Utility's Tariff on file with the Regulatory Commission of Alaska (RCA):

- By request from the customer in person or writing.

Without notice to the customer:

- When a hazard exists that threatens the safety or health of the customer, general population, or the Utility's personnel or facilities.
- When tampering with metering equipment has been detected.
- When fraud has been detected.

With notice to the customer:

- For delinquent accounts.
- Due to lack of access to the Utility's meter or equipment on the property.
- After breach of a special contract.

106 Service Complaints

106.1 Customers may file complaints with the Utility concerning the adequacy of electric service provided, or if they believe the Utility has failed to comply with rules and regulations of its Tariff. Complaints should be directed to the attention of the General Manager of ML&P, 1200 E. 1st Avenue, Anchorage, AK 99501 or, in the Chugach service area, to the Chief Executive Officer, Chugach Electric Assoc., Inc., PO Box 196300, Anchorage AK 99519. Upon receipt of a complaint, the Utility will investigate and respond to the customer in writing within 10 working days. Complaints that are not resolved to the satisfaction of the customer may be presented to the RCA for review. The RCA may be contacted at 701 W. 8th Avenue, Suite 300, Anchorage, AK, 99501, or by phone at 276-6222.

107 Coordination Responsibilities

107.1 ML&P is a regulated municipal electric utility serving a large portion of the commercial and high-density areas of the Municipality of Anchorage. Chugach is a regulated electric utility cooperative that serves the commercial and residential area of the MOA outside of the ML&P service area and extending to Indian, Girdwood, Whittier, Hope, Cooper Landing, Moose Pass and Tyonek. ML&P and Chugach will gladly assist their customers with planning for and obtaining electric service to new or remodeled installations. However, coordination with other utilities such as water, telephone, communications, and natural gas is the customer's responsibility. The Utility will make every effort to help their customer(s) identify which of the other utilities may need to be contacted for other aspects of the customer's service project but the responsibility for contact and coordination remains with the Utility's customer.

SECTION 200 - SERVICE

201 Character of Service

201.1 Electric service is available at alternating current, 60-hertz, single-phase or three-phase, from an overhead or underground distribution line, at one of the nominal American National Standards Institute (ANSI) standard voltages ($\pm 5\%$) as given below. If three-phase service is required where only single-phase service is available, the customer shall pay the cost of providing three-phase service based on service feasibility guidelines in Section 204. In addition, the customer may be required to receive underground service as required by Title 21 of the Anchorage Municipal Code, "Underground Ordinance." The Utility can assist the customer in making this determination.

202 Types of Service

202.1 Voltages available to the Utility's customers are listed as follows:

Secondary Voltages:

Single-phase, 120/240 volt, 3-wire

Single-phase, 240/480 volt, 3-wire

Three-phase, 120/208 volt, 4-wire, grounded-wye

Three-phase, 277/480 volt, 4-wire, grounded-wye

Note: Network metering is available with prior approval.

Primary Voltages:

Three-phase, 2,400/4,160 volt, grounded-wye

Three-phase, 7,200/12,470 volt, grounded-wye

Three-phase, 14,400/24,900 volt, grounded-wye (Chugach service area only)

Three-phase, 19,920/34,500 volt, grounded-wye (ML&P service area only)

202.2 Primary voltages are the highest voltage levels the distribution system has available for electric service before transformation to a secondary delivery or utilization voltage. Delivery will be made at the standard available primary voltage in the applicable service area.

202.3 All nominal voltages listed above may not be available at all locations or for all loads. Contact the Utility's Engineering Division to determine voltage level availability and service entrance limitations prior to purchasing equipment.

SECTION 200 - SERVICE

203 Application for Service

203.1 **To obtain electrical service from ML&P**, a building owner, or his representative, must complete, sign, and file an Electrical Service Extension Request at ML&P's office with the assistance of the Line Extension Coordinator. Application should be made as far in advance as possible before service is required. Application can be made at the Engineering Division located at 1200 E. 1st Avenue, Monday through Friday between 7:30 a.m. and 4:30 p.m. or on line at <http://www.mlandp.com>. The Line Extension Coordinator can be reached at 263-5212.

To obtain electrical service from Chugach, a building owner, or authorized representative, must initiate an electric account with Chugach by completing the Application for Service (residential and business application forms are available at <http://www.chugachelectric.com>) and bringing it to Member Services at 5601 Electron Drive between the hours of 8:00 a.m. to 5:00 p.m., Monday through Friday. Chugach requires applicants for electric service to show identification and may require payment of a meter deposit and connect fees to establish electric service. Member Services can be reached at 563-7366, if more information is needed.

If Chugach does not have a power source adjacent to the customer's property, a line extension may be required (a line extension is the extension of primary electric facilities to the customer's property, subdivision or commercial building). In some cases, existing Chugach facilities may be inadequate and upgrading will be required. For additional information, contact the Project Coordinator at 762-4631. A deposit is required to request a preliminary design and cost estimate for the line extension. The request for a line extension should be made as far in advance as possible (the Line Extension Application form is available at <http://www.chugachelectric.com>).

SECTION 200 - SERVICE

204 Service Feasibility

ML&P

ML&P will construct the facilities necessary to extend service to any customer within its certified service area if the extension of service is determined by ML&P to be economically feasible. ML&P uses the following guidelines to determine feasibility:

- 204.1 An overhead line extension will be considered economically feasible if the cost of the extension does not exceed five (5) times the estimated gross annual income that will be derived from the sale of electricity delivered over the extension. Refer to ML&P Tariff Rule 3.1.
- 204.2 An underground line extension will be considered economically feasible if the customer agrees to reimburse ML&P for the cost of necessary conduit, vaults, clearing, trenching and backfill for the primary line extension, all pavement cutting, removal, and replacement, and steam thawing, and if the remaining cost to ML&P does not exceed five times the gross annual income estimated by ML&P to be derived from the sale of electricity delivered by the extension. Refer to ML&P Tariff Rules 3.1 and 8.5.
- 204.3 If ML&P determines that the cost of the line extension will exceed five (5) times the estimated gross annual revenue, then ML&P will construct the extension only if the customer pays the difference (reimbursable portion) prior to construction or executes a written contract guaranteeing that the gross income derived from the line extension over a five (5) year period of time will meet or exceed ML&P's cost of the line extension. The contract shall provide for monthly payment by the customer of the charges and fees for services furnished over the line, or one-sixtieth (1/60) of the construction cost born by ML&P, whichever is greater. If additional customers apply for service from the same line extension, service will be provided to them only upon execution of an agreement to incur a minimum monthly billing based on an equal apportionment of the one sixtieth (1/60) of the cost among the total number of customers receiving service from the extension. Each contract so executed shall terminate on a date five (5) years after the first connection to service. Refer to ML&P Tariff Rule 3.3.

Chugach Electric

Chugach will construct the facilities necessary to extend service to any customer within its certified service area if the customer agrees to pay for their share of the cost of the extension of service.

- 204.4 Refer to Chugach Tariff Rule 8 for details on line extensions and modifications of electric distribution facilities. Rule 8.6 provides information on the economic feasibility of the line extension and Rule 8.7 details the calculation of credits applied to line extensions.
- 204.5 Submittal of a complete Line Extension application and deposit to Chugach initiates the process. Deposits are \$100 per residential unit, and \$300 per commercial unit. All relevant plat, site plans, civil drawings and electric load requirements for the project are to be provided with the submittal (revised drawings should be provided as they become available).
- 204.6 A preliminary design and cost estimate are prepared for the customer's review. The customer is required to sign an agreement that the cost estimate and the preliminary design meet the customer's requirements before the project can proceed to final design.

SECTION 200 - SERVICE

204 Service Feasibility

- 204.7 After the completion of the final design, acquisition of any easements and permits and the bid authorization is prepared for review and signature by the customer. This signature authorizes Chugach to release the project for bid. After bids are received, a line extension agreement is finalized for signature by the customer. The project will be released for construction when the agreement has been signed, and after the customer has paid any monies due (payment plans are available for single lot, residential line extensions).
- 204.8 A customer may hire an Alaska licensed professional electrical engineer to design/inspect and a contractor (Alaska electrical administrator license, unlimited line work category) to construct a new line extension under the conditions described in Chugach Tariff Rule 8.9.

205 Electric Service Extensions to Permanent Facilities

- 205.1 ML&P will usually extend up to one-hundred (100) feet of service conductor for single-phase services and up to sixty (60) feet of service conductor for three-phase services. Except where otherwise specified in these requirements, the length of service conductor extended is from the Utility's nearest overhead or underground facilities suitable for providing service to the customer's service entrance location, provided that the Utility's facilities are of proper capacity to serve the customer's needs. The customer **shall pay** all costs for pavement cutting, removal, and repair related to the service extension. Within the Chugach service area the maximum length of the service to permanent buildings is based on the electric load and location of the Chugach power source. In all cases the service equipment shall be located at the nearest point on the structure relative to the Chugach power source. For single-phase services, to buildings 200A and less, the customer will be responsible for the additional cost listed in Part B Special Service Installations of the Chugach Tariff for secondary service in excess of 100 feet (or the nearest point of service, whichever is shorter). Chugach places additional limits on the length of three-phase services larger than 1600A and remote meter installations.
- 205.2 If upgrades to the Utility's system become necessary, ML&P may require the customer to pay for such upgrades based upon Section 204: Service Feasibility guidelines (Chugach will determine any customer upgrade charge based on Chugach Tariff Rule 8).
- 205.3 If an application for underground service is received after the first day of **September** and before thaw the following year, frozen ground may necessitate that the underground service be installed either by steam thawing, or temporarily above ground. The customer **shall pay** all thawing related costs. When underground service is installed temporarily above ground, it shall be installed in corflo duct or electrical nonmetallic tubing. Only secondary service conductors (less than 600 volts) may be temporarily installed above ground (all services 480V line-line or greater require thawing and trenching or placement in HDPE conduit). The Utility will not install corflo/conduit above ground across roadways, driveways, or other locations subject to vehicle or equipment traffic.
- 205.4 The customer will receive underground service where the Utility's facilities are underground. Where ML&P's facilities are overhead, the customer may receive either overhead or underground service subject to the Underground Ordinance, Title 21 of the Anchorage Municipal Code. Within the Chugach service area, where facilities are overhead, all new services require an underground configuration (where they are subject to Underground Ordinance, Title 21 of the Anchorage Municipal Code). Outside of the area subject to the Underground Ordinance the Chugach customer may receive either overhead or underground service from existing overhead facilities.

SECTION 200 - SERVICE

205 Electric Service Extensions to Permanent Facilities

205.5 Within the Chugach service area non-typical residential service entrance locations require prior approval by Chugach. Service entrances at any location on the residential structure, other than within three feet from the corner of the structure that is closest to the power source designated by Chugach are non-typical. Residential post mounted (remote) meter base installations require prior approval by Chugach of a location within thirty feet of the residence structure's typical service entrance location, outside of the utility easement and on the customer's property within the normal service alignment (based on the typical structure mounted meter location). A permanent sign (8" x 5" minimum) shall be attached to an unobstructed surface of the building nearest to the power source (the typical service location) and five to six feet above final grade. The sign shall be labeled "REMOTE ELECTRIC METER DISCONNECT located 00 ft south/north and 00 ft east/west". The installer shall substitute the actual distances and bearing directions (accurate to within five feet). The background color for the sign shall provide sufficient contrast with the siding color to be recognizable at a distance of ten feet in daylight and the lettering legible at three feet. Refer to 308.41 and 308.42 for additional signage requirements.

206 Electric Service Extensions to Temporary Facilities

206.1 The Utility will extend temporary service to the customer's service entrance equipment at a location designated by the Utility provided that the Utility facilities are of proper capacity to serve the customer's needs. The ML&P customers **shall make** arrangements to pay ML&P for installation and removal costs including material, labor, equipment, and indirect overhead costs, less salvage value of materials returned to stock, prior to service construction by ML&P.

206.2 If an application for temporary underground service is received after the first day of September and before thaw the following year, frozen ground may necessitate that the underground service be installed either by steam thawing or temporarily above ground. The customer **shall pay** all related costs. When underground service is installed temporarily above ground, it shall be installed in corflo duct or electrical nonmetallic tubing. Only secondary service conductors (less than 600 volts) may be temporarily installed above ground (all services 480V line-line or greater require thawing and trenching unless the temporary corflo protected service is located within a fenced, controlled access area or the conductor is placed in HDPE conduit). The Utility will not install corflo/conduit above ground across roadways, driveways, or other locations subject to vehicle or equipment traffic.

206.3 The customer will receive temporary underground secondary service where the Utility facilities are underground. Where the Utility's facilities are overhead, the customer may receive either temporary overhead or underground service subject to the Underground Ordinance, Title 21 of the Anchorage Municipal Code.

SECTION 200 - SERVICE

207 Easements

- 207.1 Easement definition: An easement is an interest in land of another for a specific purpose. In the case of an electric utility such as ML&P or Chugach, it includes the right of access over the easement area, the right to cut down or trim any part of a tree within the easement, the right to remove any obstructions within the easement area that interfere with construction or maintenance activities. No permanent structure will be allowed within the easement. Pavement, fences, shrubbery and gardens may occupy the easement area, but only at the property owner's risk.
- 207.2 The Utility will only construct, own, operate, and maintain facilities on public or private property across which easements or rights-of-way satisfactory to the Utility have been obtained without cost or within the public streets, roads, or highways in which it has legal rights to occupy without future relocation liability. As a condition of service, the Utility may require the execution of an easement or easements providing suitable right-of-way for the construction and maintenance of the distribution lines serving the customer's premises. It is the Utility's policy not to enter into "blanket" easements.

208 Customer Facilities

- 208.1 Before any service entrance equipment is installed on any building or structure, or before any substantial changes are made to any existing service, the customer, builder, or authorized representative shall obtain approval from the Utility's Engineering Division as to where the service entrance equipment and meter socket shall be located. Refer to Section 302 for specific details regarding metering and service equipment location requirements.
- 208.2 The Utility shall require the customer to provide a suitable path from the power source to the service entrance equipment. The route must be clear of all trees, shrubs, brush, stumps and debris (within the Chugach service area a 10-foot wide path following the most direct route is required). For underground service installations, in the Chugach service area, the slope of the route must be no more than 3:1 for inline installations and no more than 4:1 where the trench traverses the slope. Where these slope conditions are not met, Chugach must either approve the route in advance (based on specific site conditions) or an alternative meter and service entrance equipment location is required. In all cases where an exception is made to install a trench in a steeper slope, the customer accepts responsibility for restoration and maintenance of the trench to control possible erosion. Chugach will backfill the trench in accordance with standard practices.
- 208.3 The customer's premises shall be at plus or minus six (6) inches from final grade prior to the Utility's installation of underground cables, conduit, meters, or other related equipment. The customer is responsible for providing locations of existing or proposed private (non-utility) subsurface facilities (e.g. storm drain, septic, heated driveway/sidewalk, lighting circuits etc.).
- 208.4 The customer shall install and maintain all wiring equipment beyond the point of delivery including meter sockets, disconnect devices, circuit protection devices, CT cabinets, CT mounting bases, wall-mounted pull boxes with terminating facilities and any similar or related electrical enclosures. The Utility shall provide all kilowatthour meters, CTs, transformer rated test switches, and associated wiring. The point of delivery, unless otherwise specified, is that location on the exterior of the customer's building or structure where the Utility's system and the customer's facilities are interconnected.

SECTION 200 - SERVICE

208 Customer Facilities

- 208.5 The customer's wiring, meter socket, and service entrance facilities shall be installed and maintained by the customer in conformity with applicable municipal or state requirements, current standards required by the National Electrical Code and the Utility's Electric Service Requirements and Tariff. Service entrance conduit sizing shall be coordinated with and approved by the Utility's Engineering Division prior to installation. Refer to Section 520 for service riser conduit details.
- 208.6 A certificate of inspection is required and **shall be** furnished before service is connected. The Utility may disconnect, refuse to connect or reconnect a service when the customer's wiring of facilities is found to be non-compliant with applicable codes, ordinances, and requirements. Refer to Section 400 for specific details on electrical inspections.
- 208.7 The customer is responsible for providing suitable protective devices for equipment installed on the customer's premises. The customer shall protect equipment with special service requirements from potentially harmful conditions, including but not limited to single-phase operation of equipment requiring three-phase service or under-and-over voltage conditions. ML&P customers refer to ML&P Tariff Rule 5.3.
- 208.8 If a customer requires a degree of regulation of the characteristics of the electrical service greater than that normally furnished by the Utility, the customer is responsible for obtaining, installing, and maintaining the required regulating equipment.

209 Service Conductor Connection

- 209.1 Connections on the "load-side" of the customer's meter socket, switchgear, or bus are the customer's responsibility. The Utility shall install service conductors between the customer's service entrance equipment and the transformer, pole, or pedestal, but the service conductors will remain de-energized until the customer has completed load-side connections and has passed an electrical inspection by the Municipality of Anchorage (or the State of Alaska for all non-residential and tri-plex or larger multi-residential services outside of the MOA inspection area). All other service connections shall be made and/or terminated by the Utility and/or its representative. If the customer requires the service to be disconnected for any reason, the customer shall contact the Utility.

SECTION 200 - SERVICE

210 Service Facilities on Customer's Premises

- 210.1 All facilities furnished by the Utility on the customer's premises **shall remain** the property of the Utility and may be removed, replaced, or updated by the Utility at any time. The customer shall provide space for and exercise care to protect the Utility's property located on the customer's premises. In addition, the customer **shall not** break the Utility's equipment seals. The customer shall be liable for loss or damage to the Utility's property arising from neglect, carelessness, vandalism, improper protection from ice, snow and water, or misuse by the customer or any other person on the customer's property.
- 210.2 Tampering with meters is prohibited by the Utility and is a civil offense under Alaska Statute (AS 42.20.030 and AS 42.20.040). Any tampering, breaking of meter seals, opening or damaging of the Utility's locks, interference with, or any work performed upon the meter installation or other property of the Utility is prohibited. The Utility may, at any time, and without notice, discontinue service to the customer and remove the meter or meters and equipment in the event of such tampering or interference. The customer **shall be** responsible for payment of all costs which result from such tampering or interference with the Utility's property. Costs may include, but are not limited to, disconnection and reconnection charges, investigation-related costs, repair costs associated with damage to the Utility property, and payment for service consumed but not metered. Service shall not be restored to such customer until payment has been made to the Utility for all incurred costs. Within the Chugach service area a tampering fee, in accordance with Chugach Tariff Rule 4.2, applies in addition to other costs outlined above.
- 210.3 On underground service installations requiring pad-mounted equipment or any other above-grade equipment such as secondary pedestals, the customer is required to furnish an accessible and safe location for this pad-mounted equipment on the customer's property. All pad-mounted or above-grade equipment site locations shall be approved by the Utility's Engineering Division. The Utility will not install pad-mounted or above-grade equipment on property other than that owned by the customer (except for service to load centers); this equipment **will not** be installed in a street or alley right-of-way, or on an adjacent neighbor's property. There shall be a minimum clearance from trees, shrubs and building walls of ten (10) feet in front of the pad-mounted equipment. Consult with the Utility's Engineering Division for specific details regarding acceptable side clearance dimensions for pad-mounted equipment. Clearance above the pad-mounted equipment should be sufficient to provide crane clearance for installation and replacement. Where required, the customer shall install, at his expense, suitable protective or security devices designated by the Utility on the customer's premises.
- 210.4 ML&P's Construction Standard EC11 in Section 700 addresses transformer clearance requirements regarding pad-mounted transformer placement near non-utility structures and for maximum length of underground services. For installations within the Chugach service area refer to Section 701.
- 210.5 The Utility's employees shall have access to customer's premises at all reasonable times for the purpose of reading meters, testing meters and related equipment, inspecting the customer's load and equipment, installing, repairing, removing, or exchanging equipment belonging to the Utility. The customer **shall not** erect or have any device, building, fence, shrubs, trees, etc., that would impede access to the Utility's equipment.

SECTION 200 - SERVICE

211 Undesirable Service Characteristics

- 211.1 The Utility may refuse or discontinue service to a customer's installation if the installation has load characteristics that may cause excessive voltage fluctuations, impairment of service, or damage to the facilities of the Utility or other customers. Undesirable load characteristics include, but are not limited to, a twenty (20) percent unbalanced load between phases, a power factor below ninety (90) percent, or cyclical demand fluctuations produced by the customer's equipment (electric welders, elevator motors, etc.). The Utility may require, as a condition of service that customers install, at their expense, equipment that will eliminate the undesirable load characteristics. Refer to ML&P Tariff Rule 5.8 for specific details (within the Chugach service area refer to Chugach Tariff Rule 4.4).
- 211.2 Devices which produce harmonic distortion such as adjustable speed drives, electronic ballasts for fluorescent lighting, switching power supplies for computers, and electric vehicles shall be filtered such that the harmonic distortion resulting from these devices is kept within the limits specified in the most recent revision of IEEE 519, Section 10. Compliance with this requirement shall be based on voltage and power quality measurements taken at the point of delivery by the Utility.
- 211.3 The customer shall consult with the Utility's Engineering Division before making the installation of all single-phase motors larger than 10 hp and all three-phase motors larger than 25 hp. The Utility will study and determine the effects of larger motors on the system at the proposed location and may require the customer to use reduced-voltage starters or other types of control systems to mitigate the effects of the equipment operation on other customers. The maximum horsepower of all motors that a customer can have running at any one time on a single-phase line on one service is 40 hp.

212 Electrical Generators and Transfer Equipment

- 212.1 The Utility's policy dictates that any business or individual requesting electric utility service in conjunction with installing legally required emergency systems, legally required standby systems, or optional standby systems, hereafter referred to as emergency/standby systems, have appropriate transfer equipment and all service equipment related to these systems be installed at the location requiring electric utility service in order to address important safety and reliability concerns for the Utility's personnel and equipment as well as the Utility's customers and the general public.
- 212.2 The Utility will deny service to or disconnect service from any premises or facility that is connected to another electrical system other than the customer's emergency/standby electrical system connected through a Utility approved transfer switch.
- 212.3 The Utility shall require a one-line electrical diagram of the proposed installation showing the normal source (utility power), the alternate source (emergency/standby system), and an accurate depiction of the transfer switch employed. The Utility will also require the electrical generator manufacturer's specific ratings and capacities for the unit proposed, the transfer switch manufacturer's specific ratings and capacities for the transfer switch proposed, and a detailed description of transfer switch operation. If the transfer switch is intended for parallel operation (closed-transition type), the customer shall also provide specifications of all interconnecting equipment including, circuit protection (protective relays), instrumentation, measurement, and control equipment. Within the Chugach service area this information shall be submitted to the Engineering Division.

SECTION 200 - SERVICE

212 Electrical Generators and Transfer Equipment

- 212.4 Transfer switches must be of a design that will ensure that back feed into the Utility's electrical system will be prevented. Transfer switches, both open-transition type and closed-transition type, shall be approved by the Utility prior to installation. The Utility shall make the sole determination as to whether or not an emergency/standby electrical system installation meets the Utility's Electric Service Requirements and provides an appropriate level of protection against back feed into its electrical system.
- 212.5 Except for routine testing or maintenance, emergency/standby systems **shall only be operated** when the Utility's electric distribution ceases to be energized, whether by system fault or disturbance, or by the Utility's system maintenance activities.
- 212.6 Manual transfer switches **shall be** of the double-throw, open-transition type.
- 212.7 Automatic transfer switches **shall be** the open-transition type except as provided in ML&P Tariff Rule 6.12.5, for installations served by ML&P (within the Chugach service area refer to sections 212.9 and 212.10 for closed transition automatic transfer switch installations). Automatic transfer switches must provide for manual transfer of customer load. Automatic transfer switches shall have both mechanical and electrical interlocks to prevent parallel operation of the customer's emergency/standby electrical system with the Utility's electrical system. For any non-approved automatic transfer switches the customer is required to submit manufacturer supplied documentation denoting (underlined/highlighted and page number references) where the auto-transfer switch manufacturer describes compliance with the manual transfer, mechanical and electrical interlock requirements, to the Utility Engineering Division.
- 212.8 Modifying or overriding transfer switches **is not** acceptable. The Utility will deny service to or disconnect service from any premises or facility with an emergency/standby electrical system that is found to have any modifications made to a transfer switch, unless such modifications are in compliance with the listing of the device by an approved testing laboratory and have been approved in writing by the Utility.
- 212.9 Emergency/standby electrical systems intended for parallel operation (closed-transition type) **shall not** be installed until the customer has entered into an agreement for operation of closed-transition transfer switches with the Utility. Subsequent to the written agreement with the Utility, and prior to the system being made operational, the customer shall schedule with the Utility a time for initial inspection and testing of the closed-transition transfer switch and emergency/standby electrical system.
- 212.10 Emergency/standby systems with closed-transition transfer equipment shall be operated in a manner that minimizes the dwell time (time both systems are in parallel operation) to only that amount of time necessary to achieve successful transfer when the Utility's electric distribution system returns to its normal energized state.
- 212.11 Key-type interlock systems employing key cylinders and locking bolts, and ratcheting or pivoting plates that attempt to externally connect two independent circuit breakers in a break-before-make scheme are not allowed by the Utility. Within the ML&P service area refer to Rules 6.12.1, 6.12.2, and 6.12.3 of the ML&P Tariff. Within the Chugach service area Chugach shall make the sole determination as to whether or not a stand-by electrical system installation meets Chugach's requirements and provides an appropriate level of protection against backfeed to its electrical system.
- 212.12 Meter socket adapter transfer devices are prohibited from use on the Utility's system.
- 212.13 Transfer switches, when service rated and used as the meter disconnect, shall be lockable. Locking provisions shall conform to the requirements of Section 305.

SECTION 200 - SERVICE

212 Electrical Generators and Transfer Equipment

- 212.14 The requirements of this section apply to all rate classes of customers, to both single-phase and three-phase services, and to both self-contained and CT rated service installations.
- 212.15 The requirements of this section apply to high-voltage or primary metered service installations.

213 Customer Sub-Metering for Resale of Electricity

- 213.1 A customer shall not sell any of the electric energy furnished by the Utility unless the customer holds a valid certificate of public convenience and necessity issued by the Regulatory Commission of Alaska (RCA) for retail distribution of electric energy and the customer has executed a contract with the Utility, or is accepting service under a schedule, which specifically authorizes the sale of electricity. This rule does not prohibit a customer from recovering the cost of electric service to rental units, proportionately with electric usage, provided the service location meets the terms set forth in ML&P Tariff Rule 8.6 or 8.7. Within the Chugach service area this provision applies to multiple-occupancy buildings only.
- 213.2 Customer sub-metering for the purposes of apportioning costs between two or more units in a master-metered premises is not the sale of electricity.
- 213.3 Where customer sub-metering equipment exists or is being constructed for the purposes of apportioning costs and if the Utility is requested to take over the sub-metering equipment and accepts it as the Utility point of delivery, such sub-metering equipment shall meet all the applicable requirements and specifications for multiple metering as stated in this book. The sub-metering equipment requires permanent labels indicating customer owned status (refer to Section 308).

214 Interconnection and NET Metering

- 214.1 The Utility has developed comprehensive requirements regarding interconnection of non-utility generating equipment and NET metering. Refer to ML&P's publication, "Interconnection and Operating Requirements for Non-Utility Generation Up to 5,000 kVA, 2010 Edition" for ML&P service area installations. Refer to Appendix C of Chugach's Tariff, Interconnection & Operating Guidelines for Non-Utility Generation up to 5,000 kVA, for installations within the Chugach service area.
- 214.2 Meter and service equipment installed in conjunction with non-utility generation equipment shall meet all applicable requirements of the Utility's Electric Service Requirements.
- 214.3 Refer to ML&P Tariff Rule 10. NET METERING for additional information. Within the Chugach service area refer to the NET METERING SERVICE section of the Chugach Tariff for additional information.

SECTION 300 – METERING AND SERVICE EQUIPMENT

301 Scope

- 301.1 The Utility's metering and service equipment requirements are based on practices that are necessary to supply uniform, satisfactory, and safe service.
- 301.2 Interpretations or clarifications of the intent of these requirements are subject to the Utility's approval.
- 301.3 As used in this book, the term "approved" means authorized, sanctioned, permitted, or specified by the Utility. In most cases, the approval will be in written or published form.
- 301.4 The requirements, guidelines, and specifications in this book apply to the type, installation, and operation of equipment related to the supply and metering of electric service from the Utility's system to a customer's premises. These requirements, guidelines, and specifications apply to all parts of the customer's service entrance equipment including meter disconnects, service disconnects, main service disconnects, customer generators, generator transfer equipment, and non-utility generation equipment. These requirements, guidelines, and specifications apply to the customer's service entrance equipment regardless of the voltage rating of the equipment. See Sections 212, 214, 311, and Subsection 303.1 for reference.
- 301.5 The information in Section 300 is general in nature and applies to the installation guidelines and specifications in Section 500 and to the service equipment specifications in Section 600 where applicable. Each installation guideline and specification and each service equipment specification may also contain additional information which should be considered unique to that guideline or specification unless reference is made to another guideline, specification, or section.
- 301.6 All metering and service equipment installed in the Utility's service area must conform to the latest state adopted revision of the NEC, to the MOA's local amendments to the NEC, to the latest state adopted revision of the NESC, and to the Utility's requirements as stated in this book.
- 301.7 Information on electrical inspection guidelines and instructions on how and when to schedule an inspection with the Municipality of Anchorage, the State of Alaska and Chugach may be found in Section 400.
- 301.8 Refer to the Installation Guidelines and Specifications in Section 500 for typical applications of service entrance equipment and their installation requirements.
- 301.9 Refer to the service equipment specifications in Section 600 for types of equipment acceptable for use on the Utility's distribution system.
- 301.10 The point of delivery, unless otherwise specified, is that location on the exterior of the customer's building or structure where the Utility's circuit and the customer's circuit are interconnected. The Utility's responsibility for maintenance of service ends at the first point of contact whether it is at the CT enclosure, panel bus bar, meter socket for underground, or at the weatherhead for overhead.
- 301.11 Many of the Utility's requirements, installation guidelines, and service equipment specifications are based upon requirements and drawings from the Electric Utility Service Equipment Requirements Committee (EUSERC). EUSERC is an organization composed of utility representatives from the western region of the United States that works to promote uniform electric service requirements and the design and engineering of metering and service equipment. ML&P and Chugach are EUSERC members and adopt their requirements as much as is practical for the Utility's applications.

SECTION 300 – METERING AND SERVICE EQUIPMENT

301 Scope

- 301.12 The Utility recommends that customer(s) consult with the Utility before purchasing service entrance equipment or installing it. The Utility will make every effort to review meter and service equipment drawings, diagrams, and manufacturer's literature provided by the customer and give feedback to the customer regarding the suitability of such equipment.
- 301.13 Grandfather Clause: The Utility does not recognize the term "grandfather clause." The Utility does not require customers to upgrade existing service entrance equipment when service requirements change where such equipment is functional, in good repair, and met the service equipment requirements and local, state, and national codes in effect at the time of original installation.
- 301.14 When a customer makes changes to existing service entrance equipment, the Utility requires that the entire service entrance to be brought into compliance with the Utility's Electric Service Requirements in effect at the time of the change. The only exception to this requirement is where minor repairs are made to existing equipment and such repairs do not change the characteristics of the existing service installation.

302 Metering and Service Equipment Location

- 302.1 Metering and service equipment location is subject to the Utility's approval. Prior to wiring a building or structure, or performing any electrical construction for a new service or a change in service, the customer shall request the Utility to designate the location of the customer metering and service equipment. The Utility will not be obligated to provide service to a structure at a point not designated by the Utility and a customer who proceeds without the designation of location may be required to modify the wiring or other construction to provide for service equipment at a location subsequently designated by the Utility.
- 302.2 Metering and service equipment shall be on the side of the building nearest to the Utility's overhead or underground facilities suitable for providing service. All metering and service equipment locations **shall be** approved in advance by the Utility's Engineering Division.
- 302.3 Where building occupancy requires more than one meter, the meters shall be grouped at one readily accessible location. This same general rule applies when one or more meters are added to an existing service with multi-metering equipment for a multiple occupancy building. The Utility may approve other arrangements for multiple metering locations when capacity requirements make multiple services desirable and are permitted by the National Electrical Code. However, other arrangements **must be** approved in writing by the Utility's Engineering Division. Within the Chugach service area multiple services for different voltages or combinations of single-phase and three-phase (except 208/120 network) to a single building or structure are not allowed except where the capacity requirements make multiple services desirable.
- 302.4 Metering and service equipment location specifically includes meter disconnects, service disconnects, and main service disconnects.
- 302.5 Metering and service equipment including self-contained meter sockets, multi-meter panels, CT rated meter sockets, CT cabinets, CT compartments of switchboards, meter disconnects, and main service disconnects shall be located outdoors, on the exterior of the building or structure.

SECTION 300 – METERING AND SERVICE EQUIPMENT

302 Metering and Service Equipment Location

- 302.6 The metering and service equipment (including meter disconnects and main service disconnects) may not be placed in a locked area. Metering and service equipment shall be accessible to the Utility. Access or Accessible means capability of being reached quickly for operating, reading, repairing, removing, testing, inspecting, or installing meters, transformers, switches, conductors, electrical enclosures, and related equipment without requiring those for whom access is required to climb over or remove obstacles, to unlock doors, to dismantle fences or gates, and so forth. Accessible equipment is not guarded by architectural enhancements, dogs, elevation, locks, parked vehicles, structures, or other impediments.
- 302.7 ML&P may approve an indoor location for a meter disconnect under rare or extenuating circumstances. Written approval for an indoor location for a meter disconnect must be obtained from ML&P prior to construction of the new or remodeled service. In general, locating a meter disconnect indoors will only be permitted where the indoor location is a ground floor location having an electrical room with an exterior access door on an exterior wall directly behind the other components of the service entrance equipment. ML&P will require the developer of the project, the owner of the project, and the lease holder of the facility (if one exists) to enter into a written agreement with ML&P to provide unrestricted access at all times to the room or space in which the meter disconnect is located. All applicable parts of Section 306 shall apply. Within the Chugach service area indoor locations for meters or meter disconnects are not approved.
- 302.8 Metering and service equipment shall be located level and plumb, outdoors on the customer's structure (building, post, or pedestal) and shall be firmly supported.
- 302.9 Metering and service equipment shall be in locations free from vibration or mechanical injury.
- 302.10 Metering and service equipment shall not be placed in any unsafe or hazardous location as determined by the Utility.
- 302.11 Metering and service equipment shall not be located directly over or under any stairway, ramp, or steps.
- 302.12 Metering and service equipment shall not be placed in an area subject to falling ice and snow or snow storage locations. The Utility requires that the snow shedding side of pitched roofs shall be avoided or protected by suitable barriers approved by the Utility. Within the Chugach service area the barriers or ice diverters shall be roof-mounted and are required for all metal roofs. Chugach requires metering and service equipment to be located on the gable end of the structure when it is available (required for all installations from Girdwood south).
- 302.13 Metering and service equipment shall not be located in any underground vault or other depressed location.
- 302.14 Carport, porch, or patio areas shall be avoided due to the possible future enclosure of such areas, resulting in inconvenience to the Utility and expense to the customer when it becomes necessary to relocate the metering and service equipment.
- 302.15 The Utility does not permit the installation of customer metering and service equipment on the Utility's facilities such as distribution transformer enclosures, wood poles, or pad-mount transformers.
- 302.16 Meters are not allowed on mobile structures such as trailers, houseboats, barges, cranes, dredges, draglines, or mobile pumping equipment.

SECTION 300 – METERING AND SERVICE EQUIPMENT

302 Metering and Service Equipment Location

- 302.17 Metering and service equipment, including meter sockets, CT cabinets, terminating pull boxes, switchboard service sections, meter disconnects, service disconnects, and main service disconnects, shall be located a minimum of thirty-six (36) inches (horizontal) from the centerline of the closest natural gas regulator.
- 302.18 Metering and service equipment, including meter sockets, CT cabinets, terminating pull boxes, switchboard service sections, meter disconnects, service disconnects, and main service disconnects, shall not be placed above or below the natural gas service entrance equipment.
- 302.19 Natural gas service equipment is defined by the Utility as the natural gas meter, natural gas regulator, any part of the natural gas service equipment equipped with bypass vents, and natural gas shut-off valves.
- 302.20 Metering and service equipment shall be located at a minimum of thirty-six (36) inches from any other gas or liquid fuel source such as propane, diesel fuel, heating oil, etc.
- 302.21 A suitable standing surface and working space is an important and integral part of metering and service equipment installations. Metering and service equipment locations shall meet the clearance and working space requirements of Section 521.
- 302.22 Metering and service equipment locations shall meet the clearance requirements and meter socket height requirements of Section 303.
- 302.23 If at any time the Utility determines a meter access problem exists due to impediments including fences, security barriers, building additions, landscaping, plants, trees, bushes, dogs, or hazardous materials, the customer at their expense shall relocate the metering facilities to a new location approved by the Utility's Engineering Division.
- 302.24 Refer to ML&P Tariff Rule 8.2 for specific details regarding location and installation of meters. Within the Chugach service area refer to Chugach Tariff Rule 8.5.

SECTION 300 – METERING AND SERVICE EQUIPMENT

303 Metering and Service Equipment Requirements, General

- 303.1 **Service Equipment Definition:** As used in this book, the term “service equipment” refers to meter sockets, meter socket enclosures, meter panels, multi-meter panels, service conductor termination compartments, pull boxes for service conductors, pull sections for service conductors, CT cabinets, CT compartments of switchboards, bus spacers, service disconnects, meter disconnects, main service disconnects, grounding electrodes, grounding electrode conductors, and any other equipment or enclosures related to the supply and metering of electric service from the Utility’s system to a customer’s premises. For the purposes of this book, the terms “service equipment” and “service entrance equipment” are synonymous terms.
- 303.2 **Approved:** As used in this book, the term “approved” means authorized, sanctioned, permitted, or specified by the Utility. In most cases, the approval will be in written or published form. Approval may refer to the type or style of equipment, to the arrangement of equipment, to the service entrance equipment location, or as otherwise stated.
- 303.3 **Standards:** The meter socket and enclosure shall be designed in accordance with the latest revision of AEIC-EEI-NEMA Standards for Watthour Meter Sockets, Publication ANSI C12.7 and with Underwriters Laboratories Standard for Meter Sockets, UL414.
- 303.4 **Meter Sequence:** The approved metering arrangement considered to be standard and required by the Utility provides for the line current to first enter the meter and then the disconnecting means and overload protective devices, (meter-switch-fuse sequence). The only exception to this is for multiple metering installations with seven or more meter socket positions.
- 303.5 **Socket Ring:** All meter sockets shall be ring type; ringless sockets are not allowed under any circumstances or conditions.
- 303.6 **Installation Responsibility, Self-contained Meter Sockets:** Self-contained meter sockets, approved by the Utility, shall be furnished, installed, and wired by the customer. Refer to Section 307 for requirements and specifications related to self-contained meter sockets. Meter socket connection diagrams can be found in Section 519.
- 303.7 **Installation Responsibility, Transformer Rated Meter Sockets:** Transformer rated meter sockets, approved by the Utility, shall be furnished and installed by the customer. The Utility will furnish and install the test switch and the normal secondary wiring from the CTs to the meter socket. Refer to Section 309 for requirements and specifications related to transformer rated meter sockets.
- 303.8 **Socket Mounting:** All single position meter panels shall be surface-mount configuration. All multiple metering sockets and their enclosures shall be either wall-mounted or switchboard service section mounted. Flush mount or semi-flush mount meter sockets and/or meter panels are not acceptable.
- 303.9 Metering enclosures shall be suitable for the location. In most cases, metering enclosures must be NEMA Type 3R rated. Contact ML&P’s Meter Shop regarding suitability of NEMA Type 1 metering enclosures. Within the Chugach service area, all metering enclosures shall be NEMA Type 3R rated.

SECTION 300 – METERING AND SERVICE EQUIPMENT

303 Metering and Service Equipment Requirements, General

303.10 Meter Socket Mounting Height Requirements:

- a) Single Position Wall-Mounted Meter Panels: **The preferred mounting height for single position wall-mounted meter panels is sixty-five (65) inches.** The maximum mounting height for single position wall-mounted meter panels is seventy-two (72) inches. The minimum mounting height for single position wall-mounted meter panels is sixty (60) inches. Mounting height is measured from the centerline of the meter socket opening to the finished grade or standing surface immediately in front of the meter.
- b) Post-Mounted Meter Panels and Commercial Service pedestals: **The preferred mounting height for post-mounted meter panels and commercial service pedestals is fifty (50) inches.** The maximum mounting height for post-mounted meter panels and commercial service pedestals is sixty-five (65) inches. The minimum mounting height for post-mounted meter panels and commercial service pedestals is forty-two (42) inches. Mounting height is measured from the centerline of the meter socket opening to the finished grade or standing surface immediately in front of the meter.
- c) Multi-Metering Panels: The maximum mounting height for multi-metering panels is seventy-five (75) inches. The minimum mounting height for multi-metering panels is thirty-three (33) inches. Mounting height is measured from the centerline of the meter socket opening to the finished grade or standing surface immediately in front of the meters. The 75-inch maximum height applies to the uppermost socket opening and the 33-inch minimum height applies to the lowermost socket opening of the multi-metering equipment. This multi-metering height requirement applies to **both commercial and residential** applications.
- d) Steps, stools, blocks of wood, concrete cinder blocks, chairs, portable step ladders, or similar devices **are not** acceptable alternatives for meeting meter height requirements.
- e) A platform may be an acceptable means for complying with meter socket height requirements as long as it is permanent in nature. Platforms may be constructed from concrete, steel, or structural lumber rated for ground contact. Platforms constructed from structural lumber or steel shall be placed on a permanent foundation. If a platform is more than twelve (12) inches above grade it shall be equipped with stairs. Platforms shall be constructed according to International Building Code standards. Where platforms are used to meet height requirements, the dimensions of the platform must provide an additional twelve (12) inches of width and an additional twelve (12) inches of depth to the minimum clearance and working space requirements as defined in Section 521. The maximum height above grade for any platform used to meet height requirements shall be twenty-four (24) inches. Platforms with a standing surface more than twenty-four (24) inches above grade **are not** acceptable. If a platform is attached to the building or structure it may be subject to municipal codes for decks. Check with the Municipality of Anchorage, Development Services Department for applicability.

303.11 **Meter Socket Clearance Requirements:** Where an adjacent wall, fence, or other electrical equipment extends beyond the face of the meter socket enclosure, a ten (10)-inch minimum side clearance dimension is required. The ten (10)-inch minimum side clearance is measured from the centerline of the meter socket opening. The ten (10)-inch minimum side clearance requirement applies to all types of metering including self-contained, CT rated, commercial service pedestals, and multiple metering equipment. Refer to Section 521 for working space and clearance requirements.

303.12 **Bypass Requirements:** Except where specified otherwise in this book, self-contained service installations (225 amps or less) require meter sockets with the safety socket feature and test-block bypass facilities.

SECTION 300 – METERING AND SERVICE EQUIPMENT

303 Metering and Service Equipment Requirements, General

- 303.13 **Bypass Requirement Exemption:** Self-contained service installations (225 amps or less) qualifying under ML&P's Rate Schedule 11 and Chugach's Residential Service classification, which covers single-family dwellings for domestic and household purposes, are exempt from the requirement for meter sockets with the safety socket feature and test-block bypass facilities. The Utility exempts the following non-residential applications from the safety socket test bypass requirement: decorative lighting, thaw wires and the Lake Hood/Spennard floatplane tie downs.
- 303.14 **Bypass Facilities, Approved Type:** Where bypass facilities are required, they shall be the test-block bypass type as shown in Section 602, and shall include a safety socket feature. Refer to Subsections 307.13 through 307.18 for approved types and prohibited types of bypass equipment.
- 303.15 **Service Ampacity Ratings, General:** Service ampacity ratings as used in this book generally apply but are not necessarily limited to the sizing of combination meter disconnect device and service terminating enclosures, wall-mounted pull boxes with terminating facilities, CT mounting bases, and CT cabinets. The ampacity rating shall be used to determine the type and style of equipment used (e.g. wall-mounted style versus switchboard service section style). The ampacity rating shall also be used to determine when self-contained metering is required and when CT rated metering is required. Service ampacity ratings as used in this book are not intended to interfere with or supersede NEC load calculations or the Utility service conductor or transformer size calculations in any way.
- 303.16 **Service Ampacity Rating, Self-contained Metering:** The maximum ampacity rating for self-contained metering is 225 amps. If the meter disconnect rating or the service conductor ampacity is 225 amperes or less, then self-contained metering is required.
- 303.17 **Service Ampacity Rating, CT Rated Metering:** The maximum ampacity rating for a single CT rated metering point is 4,000 amps. For capacity requirements above 4,000 amps, consult with the Utility's Engineering Division regarding multiple points of delivery to a single facility. The minimum ampacity rating for a single CT rated metering point is 226 amps. CT rated metering shall be required if either the ampere rating of the meter disconnect exceeds 225 amps or the ampacity of the conductors supplying a meter disconnect exceeds 225 amps. Within the Chugach service area the 4,000 amp maximum capacity does not apply to all voltages and load profiles. Consult Chugach Engineering for specific application information when the ampacity rating is greater than 2,000 amps.
- 303.18 The Utility does not use class 320 or class 400 metering.
- 303.19 **Service Ampacity Rating, Wall-Mounted CT Metering:** The ampacity rating of a single CT rated metering point shall be determined by the maximum ampere rating of the meter disconnect device. Where more than one meter disconnect device is used, the rating shall be the sum of the maximum ampere ratings of each (up to six) meter disconnect. This rating shall be used to determine the ampere rating of the CT mounting base and CT cabinet dimensions. Within the Chugach service area exceptions to this ampere rating requirement are available based on the engineer's, NEC based, service equipment rating.
- 303.20 **Service Ampacity Rating, Wall-Mounted Modular Multi-Metering with Six (6) or Fewer Socket Positions:** The ampacity rating for wall-mounted modular multi-metering with six (6) or fewer meter socket positions shall be determined by the sum of the maximum ampere rating of each (up to six) meter sockets. This rating shall be used to determine the ampacity rating of the wall-mounted pull box with terminating facilities. The ampacity rating of combination residential multi-meter panels is determined by the equipment manufacturer. Within the Chugach service area exceptions to this ampere rating requirement are available based on the engineer's, NEC based, service equipment rating.

SECTION 300 – METERING AND SERVICE EQUIPMENT

303 Metering and Service Equipment Requirements, General

- 303.21 **Service Ampacity Rating, Switchboard Service Section Style Equipment:** The ampacity rating for switchboard service section style equipment shall be determined by the ampere supply rating of the switchboard section in which the Utility's conductors terminate, or the maximum ampere rating of the meter disconnect. In the case of multiple meter disconnects, the maximum ampere rating shall be the sum of the maximum ampere ratings of each meter disconnect. This rating shall be used to determine the type of CTs, the size of the CT compartment, and the size of the service termination compartment. Within the Chugach service area exceptions to this ampere rating requirement are available based on the engineer's, NEC based, service equipment rating.
- 303.22 **Conductors beyond the Point of Attachment:** The customer shall furnish and install the service entrance conductors and service equipment beyond the point of attachment to the Utility's overhead service drop or underground service conductors. All conductors between the overhead service weatherhead or underground pull section and the meter enclosure, shall be suitably enclosed and protected, and shall not be concealed except with the express consent of the Utility.
- 303.23 **Concealment of Service Equipment:** Except where otherwise specified in this book, no sealing and/or locking provisions for securing unmetered conductors or bus and no locking provisions for securing meter disconnects or main service disconnects may be placed behind any door or panel or concealed from view in any manner.
- 303.24 **Terminating Facilities for Residential Multi-Meter Panels above 200 amps:** Service terminating facilities of combination residential multi-meter panels rated from 201 amps to 600 amps shall have provisions for 2-hole pressure connectors (lugs), either compression type or set-screw type, as per Section 627. All bussing or cable conductors beyond the terminating lugs shall be provided by the manufacturer or the customer's contractor.
- 303.25 **Wire Connectors for Residential Multi-Meter Panels above 200 Amps:** Wire connectors used in conjunction with residential multi-meter panels rated from 201 to 600 amps shall use 2-hole pressure connectors (lugs), either compression type or set-screw type. The wire connector shall lay flat on the terminating facility on which it is mounted. It is recommended that wire connectors used in conjunction with residential multi-meter panels above 200 amps have a main body width of two and one-eighth (2-1/8) inches or less.
- 303.26 **Terminating Facilities for Combination Disconnect Device and Terminating Enclosures:** Service terminating facilities of combination disconnect device and terminating enclosures used in conjunction with wall-mounted modular metering shall have provisions for 2-hole pressure connectors (lugs), either compression type or set-screw type, as per Section 627. All bussing or cable conductors beyond the terminating lugs shall be provided by the manufacturer or the customer's contractor.
- 303.27 **Wire Connectors for Combination Disconnect Device and Terminating Enclosures:** Wire connectors used in conjunction with combination disconnect device and terminating enclosures rated up to 1,200 amps shall use 2-hole pressure connectors (lugs), either compression type or set-screw type. The wire connector shall lay flat on the terminating facility on which it is mounted. It is recommended that wire connectors used in conjunction with combination disconnect device and terminating enclosures have a main body width of two and one-eighth (2-1/8) inches or less.
- 303.28 **Terminating Facilities for Wall-Mounted Pull Boxes:** Service terminating facilities of combination disconnect device and terminating enclosures rated from 201 amps to 1,200 amps shall have provisions for 2-hole pressure connectors (lugs), either compression type or set-screw type, as per Section 627.

SECTION 300 – METERING AND SERVICE EQUIPMENT

303 Metering and Service Equipment Requirements, General

- 303.29 **Wire Connectors for Wall-Mounted Pull Boxes:** Wire connectors used in conjunction with wall-mounted pull boxes rated up to 1,200 amps shall use 2-hole pressure connectors (lugs), either compression type or set-screw type. The wire connector shall lay flat on the terminating facility on which it is mounted. It is recommended that wire connectors used in conjunction with wall-mounted pull boxes have a main body width of two and one-eighth (2-1/8) inches or less.
- 303.30 **Wire Connectors for CT Mounting Bases:** Wire connectors used in conjunction with CT mounting bases on CT rated services rated from 226 amps to 800 amps shall use 2-hole pressure connectors (lugs), either compression type or set-screw type. The wire connector shall lay flat on the terminating facility on which it is mounted: the connector shall not be altered or modified in any way. It is recommended that wire connectors used on CT mounting bases have a main body width of two and one-eighth (2-1/8) inches or less.
- 303.31 Wire connectors with a single mounting hole shall not be used on residential multi-meter panels above 200 amps, combination disconnect and terminating enclosures rated up to 1,200 amps, wall-mounted pull boxes rated up to 1,200 amps, and CT mounting bases rated up to 800 amps. One-hole pressure connectors (lugs), either compression type or set-screw type, are prohibited. This requirement applies to both the Utility's (line-side) terminations and the customer's (load-side) terminations.
- 303.32 **Wire Connector Clearance and Spacing:** The 2-hole pressure connectors (lugs), either compression type or set-screw type, used to terminate line side and/or load-side conductors on facilities that are Section 627 compliant, should not diminish the phase-to-phase clearance or the phase-to-ground clearance. Where clearances are diminished, a minimum clearance of one and one-half (1-1/2) inches shall be maintained on phase-to-phase clearances and on phase-to-ground clearances.
- 303.33 **Wire Connector Modifications:** Pressure connectors (lugs), either compression type or set-screw type, shall not be altered or modified in any way. This requirement applies to both the Utility's (line-side) terminations and the customer's (load-side) terminations.

SECTION 300 – METERING AND SERVICE EQUIPMENT

304 Grounding and Bonding Requirements

- 304.1 All electric services connected to the Utility's electric distribution system shall comply with all applicable grounding and bonding requirements of the latest revision of the NEC, and with any local amendments to the NEC.
- 304.2 The customer is responsible for furnishing, installing, and maintaining all components at the point of connection between the Utility and the premises wiring necessary to comply with the grounding and bonding requirements of the latest revision of the NEC and with any local amendments to the NEC.
- 304.3 The Utility requires the use of concrete encased electrodes where concrete footers exist as part of the foundation for new structures, and when practical, in remodeled structures. Within the Chugach service area and outside of the MOA inspection area, Chugach requires two driven ground rod electrodes and recommends the installation of supplemental concrete encased electrodes for all installations.
- 304.4 In commercial applications where a concrete foundation does not exist, such as pad-mounted commercial service pedestals for street lighting load centers, or post-mounted meter sockets for food/beverage carts, etc., ground rods shall be required as per the NEC.
- 304.5 Refer to the MOA Building Safety Division Handout E.05 "Guidelines for Concrete Encased Electrodes in the Municipal Building Safety Service Area" for details regarding concrete encased electrodes.
- 304.6 Ground rods used as part of the grounding electrode system shall be no less than eight (8) feet in length and no less than five-eighths (5/8) inches in diameter.
- 304.7 Where ground rods are used as part of the grounding electrode system, they shall be placed a minimum of thirty-six (36) inches from any of the Utility's underground conductors, pad-mounted transformers, or power poles.
- 304.8 Where ground rods are used as part of the grounding electrode system, they shall be placed a minimum of thirty-six (36) inches from any natural gas company underground lines or service risers.
- 304.9 Where multiple ground rods are used as part of the grounding electrode system, they shall be placed a minimum of eight (8) feet apart.
- 304.10 At least one (1) ground rod shall be installed on temporary service installations. The ground rod shall be placed no more than six (6) feet from the temporary service disconnecting means.
- 304.11 Where ground rods are used as part of the grounding electrode system, they shall be installed in a manner where the top of the rod is below the level of finished grade or the flush with the level of undisturbed soil, whichever is lower.
- 304.12 The Utility's electric distribution system is a multi-grounded system.
- 304.13 Metering equipment enclosures, including CT rated meter socket enclosures, self-contained meter socket enclosures, pull box and pull section enclosures for service conductor termination, and CT cabinets or compartments are considered non-current-carrying conductive materials forming part of the service entrance equipment. All such enclosures shall be grounded and bonded in a manner that establishes an effective ground-fault current path.

SECTION 300 – METERING AND SERVICE EQUIPMENT

304 Grounding and Bonding Requirements

- 304.14 CT rated meter socket enclosures shall be bonded to their respective CT cabinets by means of a No. 6 AWG stranded copper conductor, insulated with a green jacket. The No. 6 AWG stranded copper conductor shall be installed in accordance with all applicable articles of the latest revision of the NEC.
- 304.15 Customer system grounding connections may be made inside of CT cabinets, wall-mounted pull boxes with terminating facilities, the service termination section of combination disconnect device and terminating enclosures and switchboard service terminating pull sections as long as such connections do not interfere with the termination of the Utility's (line-side) service conductors.
- 304.16 The Utility does not install a bare grounding conductor in service drops from its overhead facilities or in service laterals from its underground facilities to either permanent service installations or temporary service installations. The Utility grounds the neutral or common conductor at the service transformer or the secondary pedestal.

305 Sealing and Locking Requirements

- 305.1 All removable access covers for compartments containing un-metered conductors shall be sealable or lockable. No removable panel or cover requiring sealing or locking shall be located behind other panels, covers, or doors except where otherwise specified in this book.
- 305.2 All top cover panels, side cover panels, and rear cover panels providing access to un-metered conductors shall be secured in place with devices that may not be loosened from the outside. Screws or bolts requiring special tools for installation or removal are not acceptable alternatives.
- 305.3 Sealable latches, stud and wing-nuts, sealing screws, or slot & tab devices shall be provided as the means of sealing removable access covers.
- 305.4 Hinged cover panels shall be lockable on the side opposite the hinges. Hinged panel covers shall accept a padlock with a shackle diameter of not less than five-sixteenths (5/16) inch.
- 305.5 Removable cover panels shall be sealed with stud and wing-nut assemblies on opposite sides of the panel. Alternate sealing methods may be used if the removable covers are self-supporting with the captive screws and sealing provisions removed.
- 305.6 Stud & wing nut sealing assemblies shall consist of a 1/4-inch x 20 (minimum) stud and associated wing nut, each drilled 0.0635 inch (minimum) for sealing purposes. The stud shall be securely attached so as to not loosen or back out when being fastened.
- 305.7 Sealing screws shall be drilled 0.0635 inch (minimum) for sealing purposes.
- 305.8 Locking devices shall be designed to sufficiently resist unauthorized access and shall be made of a durable corrosion resistant material.
- 305.9 All securing screws for removable panel covers shall be captive.
- 305.10 All sealing and locking provisions must be Original Equipment Manufacturer (OEM), provided and installed by the equipment manufacturer or be an OEM field retrofit kit provided by the manufacturer. Sealing and locking provisions provided by a third party manufacturer are not acceptable.

SECTION 300 – METERING AND SERVICE EQUIPMENT

305 Sealing and Locking Requirements

- 305.11 All CT cabinets and compartments shall have hinged front cover access to the CTs. The hinged front cover shall be lockable and shall accept a padlock with a shackle diameter of not less than five-sixteenths (5/16) inch. The hinged front cover requirement applies to all CT compartments, single-phase, or three-phase, in both wall-mounted and switchboard style applications.
- 305.12 The term “lockable” is defined as accepting a padlock with a shackle diameter of five-sixteenths (5/16) inch. Under certain specified circumstances, padlocks with shackle diameters of one-quarter (1/4) inch may be used.
- 305.13 Key lock handles where the locking mechanism is an integral part of the handle assembly are not an acceptable means of locking or securing doors or panels covering any space, compartment, or section with unmetrated conductors or metering equipment or meter disconnect devices or main service disconnect devices.

306 Service and Meter Disconnect Requirements

306.1 Disconnect Nomenclature

The term “Service Disconnect” can refer either to a “Meter Disconnect” or a “Main Service Disconnect.” The distinctions between a “Meter Disconnect” and a “Main Service Disconnect” are described in their respective sections below.

306.2 Meter Disconnects, 600 Volts or Less, General

- a) For each and every meter, the customer shall furnish and install a circuit breaker, fused switch, or other approved disconnecting means with over-current protection referred to in this book as a “Meter Disconnect”.
- b) The meter disconnect shall control all of, and only the energy registered by its related meter.
- c) In certain types of CT rated metering applications, the meter disconnect may consist of up to six (6) separate devices.
- d) Except where otherwise specified in this book, a circuit breaker, when used as a main disconnect device in a “Main Distribution Panel” (MDP) other than used in a switchboard service section, **does not** meet the requirements for a meter disconnect device. ML&P prohibits the use of MDPs as meter disconnect devices. Within the Chugach service area the use of the MDP breakers as meter disconnect devices is permitted when each breaker meets all the requirements for locking and the outer access door is not lockable.
- e) Where an MDP is part of switchboard service section style equipment and where the main distribution section is connected by cross bus from a switchboard metering section, the main device in a main distribution panel may be used as the meter disconnect device as long as it meets requirements for lockability and as long as it is not enclosed with a cover other than the outdoor enclosure for switchboards as defined by Section 619.

SECTION 300 – METERING AND SERVICE EQUIPMENT

306 Service and Meter Disconnect Requirements

306.3 Meter Disconnects, 600 Volts or Less, Locking Provisions

- a) Meter disconnects supplied from CT compartments shall be capable of being locked in the open position.
- b) Locking provisions may be:
 - 1) A lockout device which is incorporated as an integral part of each meter disconnect, or
 - 2) A lockable cover for each meter disconnect where the lock prevents the operation of the of the disconnect and prevents removal of the cover, or
 - 3) A lockable cover for multiple meter disconnects where the lock prevents the operation of any of the disconnects, prevents removal of the cover, and all disconnects are supplied from a single CT compartment.
 - 4) Items 1, 2, and 3 shall be permitted to be accomplished by a maximum of (2) two locking provisions per disconnect.
 - 5) For fused disconnects, the fuse access cover shall be lockable when the disconnect is locked in the off (open) position.
 - 6) All locking provisions for disconnects rated less than 400 amperes shall accept a padlock with a shackle diameter of not less than one-quarter (1/4) inch.
 - 7) All locking provisions for disconnects rated 400 amperes and above shall accept a padlock with a shackle diameter of not less than five-sixteenths (5/16) inch.

306.4 Multiple Meter Disconnects, 600 Volts or Less

- a) Where more than one meter disconnect is served from a CT cabinet, the circuit conductors exiting the CT cabinet shall be enclosed in either rigid metal conduit or in an approved wiring gutter.
- b) Where multiple meter disconnects are served from a CT cabinet and rigid metal conduit is used as the raceway for the circuit conductors, the conduit run shall have no condulets (LBs, LLs, or LRs); it shall be a direct run.
- c) Where multiple meter disconnects are served from a CT cabinet and a wiring gutter is used as the raceway for the circuit conductors, the wiring gutter shall have factory sealing and/or locking provisions.
- d) Where multiple meter disconnects are served from a wall-mounted CT cabinet or from the CT compartment of a switchboard service section, each disconnect shall be lockable and shall meet the locking requirements of Subsection 306.3.b) 6) and 7).

SECTION 300 – METERING AND SERVICE EQUIPMENT

306 Service and Meter Disconnect Requirements

306.5 Main Service Disconnects, 600 Volts or Less

- a) For the purposes of this book, a “Main Service Disconnect” is defined as a disconnect device installed on the line-side (supply-side) of a group of seven (7) or more meter sockets and may be a circuit breaker, fused switch, or other approved disconnecting means.
- b) A main service disconnect **shall be** installed on the line-side (supply-side) of a group of seven (7) or more meter sockets in accordance with NEC requirements.
- c) A main service disconnect **shall not** be installed on the line-side (supply-side) of a group of six (6) or fewer meter sockets.
- d) A main service disconnect shall be located within sight of the meter sockets which it serves. A main service disconnect may not be located indoors if the meter sockets it serves are located outdoors. A main service disconnect may not be located outdoors if the meter sockets it serves are located indoors.
- e) Main service disconnects shall be capable of being locked in the open position and shall meet the locking requirements of Subsection 306.3. b) 7).
- f) Main service disconnects, whether used in residential applications or commercial applications, shall have factory designed and installed sealing and/or locking provisions to seal or lock all areas of the enclosure except for access for fuse replacement or switch operation.

306.6 Meter and Service Disconnect Location, 600 Volts or Less

- a) Meter disconnects and main service disconnects are considered part of the service entrance equipment and are required to be placed outdoors on the exterior of a building or structure at a location approved by the Utility.
- b) Meter disconnects and main service disconnects shall meet the Utility’s requirements for access.
- c) ML&P may consider an indoor location for meter disconnects and/or main service disconnects where the customer can demonstrate unusual circumstances which would preclude a reasonable outdoor location. Under such circumstances, ML&P’s approval for an indoor location will be dependent upon ML&P’s access to the disconnecting means. Within the Chugach service area all metering equipment and supply side service terminations are required to be installed outdoors (refer to 306.7 for remote control operation option for CT metered services).
- d) Indoor locations which ML&P may consider for meter disconnect and/or main service disconnect devices will be ground floor locations having an electrical room with an exterior access door on an exterior wall directly behind the other components of the service entrance equipment.
- e) The customer shall not begin construction of a new or remodeled service that is designed with the disconnecting means located at an indoor or otherwise inaccessible location without first obtaining written permission from ML&P for the indoor location.

SECTION 300 – METERING AND SERVICE EQUIPMENT

306 Service and Meter Disconnect Requirements

- f) A main service disconnect as defined by Subsection 306.5 may not be located indoors if the meter sockets it serves are located outdoors and it may not be located outdoors if the meter sockets it serves are located indoors. The remote control option described under Subsection 306.7 will not be considered under such arrangements.
- g) Service disconnects, both meter disconnects and main service disconnects located indoors shall meet the working space and clearance requirements of Section 521.

306.7 Remote Control Option (Shunt Trip), for Meter Disconnects, 600 Volts or Less:

Meter disconnects supplied from CT compartments may be located indoors when approved in writing by the Utility. A meter disconnect and/or main service disconnect using the remote control option shall meet the following conditions:

- a) Meter disconnects located indoors shall provide for remote operation of the disconnect device or devices by means of a shunt trip device.
- b) Where more than one meter disconnect is served from a CT cabinet and located indoors, each of the meter disconnects shall provide for remote operation by means of a single shunt trip device.
- c) Meter disconnect devices placed indoors shall be located nearest the point of entrance of the service conductors.
- d) The shunt trip switch may be either a safety switch type or a two-position rotating type switch inside an enclosure.
- e) Safety switch type: must be suitable for the environment and be lockable in either the “on” or “off” position. Interlock contacts may be used to provide correct handle location. The “off” position must disconnect the power.
- f) Two-Position Rotating Switch style inside an enclosure: The two-position rotating type shunt trip switch shall be placed within an enclosure suitable for the environment and with a hinged cover. The enclosure shall be large enough for the required sign to be mounted on it. The enclosure shall have a padlock hasp with the padlock accessible for removal with bolt cutters by emergency responders. No padlocks with hardened steel shackles are permitted. Shackle diameter should not exceed five-sixteenths (5/16) inch. The two-position rotating type shunt trip switch shall be a sustained contact type with “off” and “on” clearly identified. The “off” position shall disconnect the power.
- g) Push button switches, whether momentary contact or sustained contact, are not acceptable; they are prohibited from use.
- h) The shunt trip device enclosure shall be labeled with the words “SERVICE SHUNT TRIP – UTILITY.”
- i) The label for a shunt trip disconnect switch shall be constructed from plastic laminate, having white letters on a red background. The lettering shall be one (1)-inch high, block type, open face, and meet the requirements of the most recent edition of the Uniform Fire Code.

SECTION 300 – METERING AND SERVICE EQUIPMENT

306 Service and Meter Disconnect Requirements

- j) Shunt trip devices shall meet the requirements of Anchorage Fire Department Information & Policy bulletin #05-0003, dated March 1, 2005. Refer to the MOA Building Safety Division Policy E.04 “Electrical Disconnects for the Requirements of Anchorage Fire Department Policy Bulletin #05-3000.”
- k) Meter disconnects and main service disconnects located indoors and operated by means of a remote operator (shunt trip device) shall meet the same locking requirements as those disconnect devices located outdoors. The Utility’s requirements for disconnect lockability are not abrogated or waived when locating meter disconnects or main service disconnects indoors instead of outdoors.
- l) Placing a meter disconnect at an indoor location does not abrogate or waive the prohibition of using “Main Distribution Panels” (MDPs) as meter disconnect devices. Whether the meter disconnect is placed outdoors (as required) or indoors (with written permission from ML&P), a circuit breaker, when used as a main disconnect device in a main distribution panel other than a switchboard service section, does not meet the requirements for a meter disconnect device. MDPs are prohibited from use as meter disconnect devices. Within the Chugach service area the use of the MDP breakers as meter disconnect devices is permitted when each breaker meets all the requirements for locking and the outer access door is not lockable.

306.8 Shunt Trip Testing Requirement

Service projects using the remote control option (shunt trip) for meter disconnects located indoors shall be required to demonstrate shunt trip functionality by means of an electrical test. When the customer is ready to energize a service project with a shunt trip device, the Utility shall first test energize the new or upgraded service for the purpose of testing the shunt trip equipment. A Utility representative must be present to witness the function test of the shunt trip device. Upon completion of a successful shunt trip test, the new or upgraded service may then be energized and remain so under normal conditions. No test will be scheduled until all service entrance equipment has been installed and has passed its MOA electrical inspection (or State electrical inspection outside of the MOA inspection area and within the Chugach service area).

306.9 Concealment of Service Equipment

Except where otherwise specified in these requirements, no sealing and/or locking provisions for securing unmetered conductors or bus and no locking provisions for securing meter disconnects or main service disconnects may be placed behind any door or panel or concealed from view in any manner.

306.10 Wire Terminations on Disconnects, 600 Volts or Less

The Utility’s (line-side) service conductors shall not terminate on a customer-owned circuit breaker, fused switch, or any other customer-owned disconnecting means. Approved termination facilities suitable for the application shall be provided by the customer for entrance and termination of the Utility’s (line-side) service conductors.

306.11 Service Disconnects Above 600 Volts, General

Primary metered services require an approved high voltage service disconnect on the metered side (customer’s load-side) of the primary metering cabinet. In most cases the high voltage service disconnect shall be housed in a separate enclosure external to the primary metering cabinet. The type of disconnect and its related features shall be approved by the Utility. Refer to Section 311 for requirements and specifications regarding high voltage (primary) metering.

SECTION 300 – METERING AND SERVICE EQUIPMENT

306 Service and Meter Disconnect Requirements

306.12 Visible Open Requirement for Service Disconnects Above 600 Volts

Service Disconnects used on primary metered services shall have a visible open feature as part of the disconnect switch design. A visible open in this application is defined by the Utility as a physical break in the actual high voltage circuit on which the switch is installed and which is directly observable without resorting to extraordinary means. The visible open requirement is typically satisfied by air-break disconnects or by gas insulated switchgear (GIS) type disconnects with appropriate viewing windows to observe switch contact position. Vacuum type switches do not meet the requirement for a visible open.

306.13 Locking Requirements for Service Disconnects Above 600 Volts

Service disconnects used on primary metered services shall be lockable in open position and in the closed position. The disconnect switch shall be lockable by means of a padlock with a shackle diameter of five-eighths (5/8) inches or greater. The lock, when installed, shall prevent opening or closing of the high voltage switch contacts.

306.14 Overcurrent Protection Requirements for Service Disconnects Above 600 Volts

A Utility required service disconnect used on a primary metered service (service voltage above 600 volts) installation may not necessarily be required to have overcurrent protection as an integral function of the disconnect device. In some high voltage service applications, overcurrent protection may need to be provided in a separate enclosure, in other high voltage service applications, overcurrent protection may not be required by the Utility. The type of overcurrent protection and its related features shall be approved by the Utility.

306.15 Loadbreak Requirement for Service Disconnects Above 600 Volts

Service disconnects used on primary metered services (service voltage above 600 volts) shall be capable of making and breaking load up to and including the class rating of the equipment used. Service disconnects used in conjunction with high voltage cable rated at 200 amps and high voltage separable insulated connector systems rated at 200 amps shall have 200 amp load making and load breaking capability. Service disconnects used in conjunction with high voltage cable rated at 600 amps and high voltage separable insulated connector systems rated at 600 amps shall have 600 amp load making and load breaking capability. Service disconnects used to break load current shall be marked with the current that they are rated to interrupt.

306.16 Standards Conformance for Service Disconnects Above 600 Volts

Service disconnects used on primary metered services (service voltage above 600 volts) shall conform with the most recent published revision of IEEE C37.74 Standard Requirements for Subsurface, Vault, and Pad-Mounted Load-Interrupter Switchgear and Fused Load-Interrupter Switchgear for Alternating Current Systems Up to 38 kV.

306.17 Identification and Marking Requirements for Service Disconnects Above 600 Volts

Service disconnects used on primary metered services shall be conspicuously and permanently marked (with numbers/letters/symbols) to facilitate identification by the Utility's employees. No high voltage service disconnect identification or high voltage termination enclosure identification shall duplicate any of the Utility's letters, numbers, or symbols used on its electric distribution system.

SECTION 300 – METERING AND SERVICE EQUIPMENT

306 Service and Meter Disconnect Requirements

306.18 AIC Ratings

The “Ampere Interrupting Capacity” (AIC) rating of a disconnect device is the highest current at a rated voltage that the disconnect device is intended to interrupt under standard test conditions. The Utility does not specify AIC ratings for meter disconnect, service disconnect, or main service disconnect devices. The Utility considers the determination of AIC ratings of disconnect devices to be the responsibility of the designer and/or installer. The Utility expects and requires the designer and/or installer of the equipment to evaluate a given electric service installation and install a disconnect device with an AIC rating appropriate for the specific situation.

307 Self-Contained Metering Requirements, General

- 307.1 Self-contained meters are designed to carry rated current and be energized at line potential. They do not require auxiliary instrument transformers to step down line current or voltage. Self-contained meter panels are required on all electric services with a capacity requirement of 225 amperes or less.
- 307.2 The Utility does not use class 320 or class 400 metering. Meter sockets and/or meter panels rated at 320 amperes or 400 amperes are prohibited from use on the Utility’s system.
- 307.3 All services with capacity requirements greater than 225 amperes shall use CT rated metering equipment.
- 307.4 The self-contained meter socket and enclosure shall be designed in accordance with the latest revision of AEIC-EEI-NEMA standards for Watthour Meter sockets, Publication ANSI C12.7 and Underwriters Laboratories Standard for Meter Sockets UL 414.
- 307.5 Self-contained meter sockets and/or meter panels rated at 100 amperes or 125 amperes **are acceptable** for use on the Utility’s system contingent on meeting the applicable service equipment specification (within the Chugach service area 100 ampere or 125 ampere equipment are approved for overhead services outside of the MOA underground surcharge area and for non-residential applications with test-block by-pass only). Chugach requires 200 amperes rated self-contained meter sockets and/or meter panels for all underground feed residential services.
- 307.6 Sockets for self-contained meters shall be furnished, installed, and wired by the customer. Diagrams of meter socket connections are shown in Section 519.
- 307.7 When self-contained meter sockets are installed in switchboards, they shall be wired by the switchboard manufacturer.
- 307.8 For each and every meter, the customer shall furnish and install a circuit breaker, fused switch, or other approved disconnecting means with over-current protection referred to in this book as a meter disconnect. The meter disconnect shall control all of and only the energy registered by its related meter.
- 307.9 Meter sockets for self-contained meters used in residential service applications shall have a maximum ampacity rating not less than the ampacity rating of the associated service disconnect. The maximum ampacity rating is 125% of the continuous-duty rating.
- 307.10 Meter sockets for self-contained meters used in commercial and industrial service applications shall have a continuous-duty rating of 100 amps for service disconnects rated up to 125 amps maximum and a continuous-duty rating of 200 amps for service disconnects rated up to 200 amps maximum.

SECTION 300 – METERING AND SERVICE EQUIPMENT

307 Self-Contained Metering Requirements, General

- 307.11 The maximum ampacity rating of the service disconnect device used in any self-contained meter panel, whether residential service application or commercial service application, shall be 225 amperes. Meter panels with 250-amp rated breakers are not acceptable.
- 307.12 Meter sockets used in residential service applications shall meet the requirements of Section 601, shall include a circuit breaker, fused switch, or other approved disconnecting means with over-current protection, and shall be located on the exterior of the building or other outdoor location.
- 307.13 Meter sockets used in commercial, industrial, or non-residential applications shall meet the requirements of Sections 602, 603, or 604, shall include a circuit breaker, fused switch, or other approved disconnecting means with over-current protection, and shall be located on the exterior of the building or other outdoor location.
- 307.14 Meter sockets used in all commercial, industrial, or non-residential applications shall be equipped with the safety socket feature and factory installed test-block bypass facilities. For exceptions refer to Section 303.13.
- 307.15 Meter sockets with automatic circuit closing facilities are prohibited from use on the Utility's system. Automatic-type bypasses are not allowed under any circumstances or conditions.
- 307.16 Meter sockets with horn-type manual circuit closing facilities are prohibited from use on the Utility's system. Horn-type bypasses are not allowed under any circumstances or conditions.
- 307.17 Meter sockets with slider-type manual circuit closing facilities are prohibited from use on the Utility's system. Slider-type bypasses are not allowed under any circumstances or conditions.
- 307.18 Meter sockets with lever-type manual circuit closing facilities are prohibited from use on the Utility's system. Lever-type bypasses are not allowed under any circumstances or conditions.
- 307.19 All meter sockets shall be ring type; ringless sockets are not allowed under any circumstances or conditions.
- 307.20 The service termination facilities of meter sockets used in underground service applications shall be specifically designed to receive underground service conductors. Enclosures designed for either overhead or underground service conductor entry are acceptable provided they meet the requirements for both types of service conductor entry.
- 307.21 The service cable entry section and the meter socket section shall be sealable or lockable and isolated with suitable barriers separating these sections from other integral enclosure sections which are accessible to the customer. The purpose of isolation by suitable barriers is to effectively prevent the attachment of unauthorized connections to un-metered conductors or terminals.
- 307.22 All meter panel covers for compartments or sections containing un-metered conductors shall be sealable or lockable.
- 307.23 Meter sockets used in underground applications shall have a separate cover plate for the section of the socket which receives the meter and a separate cover plate for the service conductor termination section. The Utility prohibits the use of meter sockets with a single common cover plate for both the meter socket section and the service conductor termination section.
- 307.24 Five (5) jaw meter sockets are designed for network metering applications where single-phase loads are to be connected and metered from a 3-phase, 4-wire, wye-connected, 120/208 volt system. The 5th jaw is also called a potential jaw and is connected to the neutral of the system to provide for proper operation of the meter.

SECTION 300 – METERING AND SERVICE EQUIPMENT

307 Self-Contained Metering Requirements, General

- 307.25 Network service installations require a factory installed 5th jaw or a factory supplied 5th jaw kit. The 5th jaw shall only be located in the nine (9) o'clock position.
- 307.26 Meter sockets equipped with a 5th jaw for Network service but served from a true single-phase, 3-wire, 120/240 volt source, must have the 5th jaw and its associated wiring removed from the socket.
- 307.27 Seven (7) jaw meter sockets are designed for metering applications involving three-phase loads. Meters designed for use in seven (7) jaw meter sockets may be applied on 3-phase, 4-wire wye-connected, 208/120 volt systems; 3-phase, 4-wire and wye-connected 480/277 volt systems. The 7th jaw (ANSI/IEEE C12.7) is connected to the neutral of the system to provide for proper operation of the meter. The Utility does not permit new 3-phase, 4-wire Delta-connected, 240/120 volts systems.
- 307.28 Socket rim to jaw clearance for self-contained meter sockets shall be no less than 0.500" and no more than 0.690" as per ANSI C12.7.
- Exception: The 0.690" dimension does not apply to neutral clips on self-contained sockets.
- 307.29 The Utility does not recognize and does not accept the term "farm panel."

308 Multiple Metering Requirements, General

- 308.1 The customer shall furnish and install multiple metering service entrance equipment with self-contained meter sockets and/or CT rated meter sockets appropriate for the type of service and number of metered points requested.
- 308.2 All required equipment for a multiple metering installation shall be placed at a common location, approved in advance by the Utility's Engineering Division. The Utility may approve other arrangements for multiple metering locations when capacity requirements make multiple services desirable and are permitted by the NEC. However, other arrangements shall be approved in advance by the Utility and may not be utilized without the prior written consent of the Utility. Refer to Section 302 for location requirements. Cell sites require one multiple meter configured service. Within the Chugach service area multiple services for different voltages or combinations of single-phase and three-phase (except 208/120 network) to a single building or structure are not allowed except where the capacity requirements make multiple services desirable.
- 308.3 For each and every meter, the customer shall furnish and install a circuit breaker, fused switch, or other approved disconnecting means with over-current protection referred to in this book as a meter disconnect. The meter disconnect shall control all of and only the energy registered by its related meter.
- 308.4 Each meter socket position in a multiple metering installation shall serve only one (1) dwelling unit or commercial space. One (1) meter socket position shall not serve multiple dwelling units or commercial spaces.
- 308.5 Each dwelling unit or commercial space shall be served by only one (1) meter socket position. Multiple meter socket positions shall not be used to serve one (1) dwelling unit or commercial space.

SECTION 300 – METERING AND SERVICE EQUIPMENT

308 Multiple Metering Requirements, General

- 308.6 Where a facility owner desires multiple meters to serve a single dwelling unit or commercial space, or desires one (1) meter to serve multiple spaces, written approval shall be obtained from the Utility prior to construction of the new or remodeled service. In general, in order to obtain approval, the facility owner will have to show good cause to the Utility of the technical necessity for deviating from normal practices.
- 308.7 A meter disconnect, service disconnect, or main service disconnect shall not be placed ahead of utility meters except where required by the NEC and where all meter socket positions are for self-contained metering points.
- 308.8 A meter disconnect, service disconnect, or main service disconnect shall not be placed ahead of utility meters where any of the meter socket positions are CT rated metering points under any circumstances or conditions.
- 308.9 Multiple metering equipment with six (6) or fewer self-contained meter socket positions **shall not** have a main service disconnect on the source side (line-side, ahead of the meter sockets). Installations with six (6) sockets or less shall follow the meter-switch-fuse sequence.
- 308.10 Multiple metering equipment with seven (7) or more self-contained meter socket positions **shall have** a main service disconnect installed on the source side (line-side, ahead of the meter sockets). This is the only circumstance where a customer disconnect switch is allowed ahead of the Utility's meters.
- 308.11 Multiple metering installations with seven (7) or more meter socket positions **shall have** a main service disconnect meeting the requirements of Section 306.
- 308.12 Main service disconnects installed on the source side (line-side, ahead of the meter sockets) of a multiple metering installation, whether a residential application or commercial application, **shall have** factory designed and installed sealing and/or locking provisions to seal or lock all areas of the enclosure except for access for fuse replacement or switch operation.
- 308.13 Multiple metering installations shall have service termination compartments appropriate to the style and ampacity rating of the equipment used. Refer to Sections 606, 608, 609, 625 or 626 for service termination compartment details.
- 308.14 Multiple metering installations rated at 201 amps and above shall have service conductor termination facilities meeting the requirements of Section 627.
- 308.15 The Utility's (line-side) service conductors **shall not** terminate on a circuit breaker, a fused switch, or any other disconnecting means. Approved termination facilities suitable for the application shall be provided by the customer for entrance and termination of the Utility's (line-side) service conductors.
- 308.16 Combination disconnect device and terminating enclosures used in multiple metering applications shall meet the requirements of Section 608.
- 308.17 The maximum rating for combination disconnect device and service terminating enclosures used in the Utility's service area shall be 1,200 amps. Refer to Subsections 303.13 and 303.19 for service ampacity rating details. Within the Chugach service area the maximum single-phase service equipment rating is 800 amperes for certain applications. Chugach Engineering must evaluate all single-phase services above 800A in advance of installation.

SECTION 300 – METERING AND SERVICE EQUIPMENT

308 Multiple Metering Requirements, General

- 308.18 Multiple metering installations rated at 1,201 amps and above **shall use** switchboard service section type equipment for termination of the Utility's service conductors. Refer to Subsections 303.13 and 303.19 for service ampacity rating details.
- 308.19 Switchboard service sections used in multiple metering applications **shall have** underground service termination compartments meeting the requirements of Sections 625 or 626.
- 308.20 Switchboard service sections used in multiple metering applications **shall have** underground service termination facilities meeting the requirements of Section 627.
- 308.21 Combination residential multi-meter panels with two (2) to (6) six meter socket positions shall meet the requirements of Section 606.
- 308.22 Combination residential multi-meter panels with two to six meter socket positions and with ratings from 201 amps to 600 amps shall have terminating facilities meeting the requirements of Section 627.
- 308.23 Multiple metering installations having up to six (6) meter socket positions using wall-mounted modular multiple metering equipment shall provide a wall-mounted pull box with terminating facilities for the Utility service conductor termination. The wall-mounted pull box with terminating facilities shall meet the requirements of Section 609.
- 308.24 Multiple metering equipment used in commercial applications shall have no more than three (3) meter socket positions per vertical column or module.
- 308.25 Multiple metering equipment used in residential applications shall have no more than four (4) meter socket positions per vertical column or module.
- 308.26 Multiple metering installations using switchboard service section style equipment shall meet the general requirements of Section 310.
- 308.27 Except where otherwise specified in this book, barriers used in multiple metering enclosures to separate customer sections from utility sections (e.g., pull sections and metering sections) shall be constructed from sixteen (16) gauge (minimum thickness) steel and shall be secured with devices that are not removable from either the customer's sections or the exterior of the enclosure.
- 308.28 Meter sockets used in all commercial, industrial, or non-residential multi-metering applications shall be equipped with the safety socket feature and factory installed test-block bypass facilities.
- 308.29 Self-contained meters installed in switchboards shall have meter sockets meeting the requirements of Section 603.
- 308.30 Multiple metering equipment used in residential applications qualifying under ML&P Rate Schedule 11 (or the Chugach Tariff Residential Service classification within the Chugach service area) is exempt from the safety socket and test-block bypass requirement, where all the units of the multi-unit facility are residential in nature. See Subsection 308.32 for mixed use multi-unit facilities.
- 308.31 The meter sockets of a multi-family residential building serving "house power" or "common area" loads shall be considered as "residential" with respect to safety socket and test-block bypass requirements, as long as such sockets are included as part of the common enclosure or modular component of multiple metering equipment. In such cases, the requirement for the safety socket feature with test-block bypass does not apply.

SECTION 300 – METERING AND SERVICE EQUIPMENT

308 Multiple Metering Requirements, General

- 308.32 Multiple metering equipment in mixed use applications (part commercial and part residential) shall have self-contained meter sockets equipped with the safety socket feature and test-block bypass facilities. The applicable parts of Sections 602 and 603 shall apply. The safety socket and test-block bypass exemption for residential sockets shall not apply in mixed use applications.
- 308.33 Multiple metering equipment used in residential applications shall meet the clearance requirements of Section 607.
- 308.34 Multiple metering equipment used in both residential and/or commercial applications shall meet the clearance and working space requirements of Subsection 303.11 and of Section 521.
- 308.35 The maximum mounting height for multi-metering panels is seventy-five (75) inches. The minimum mounting height for multi-metering panels is thirty-three (33) inches. Mounting height is measured from the centerline of the meter socket opening to the finished grade or standing surface immediately in front of the meters. The 75-inch maximum height applies to the uppermost socket opening and the 33-inch minimum height applies to the lowermost socket opening of the multi-metering equipment. This multi-metering equipment height requirement applies to both commercial and residential applications.
- 308.36 Installing wall-mounted modular multi-metering equipment with different capacity ratings (e.g. 100 amp rated and 200 amp rated) may result in the inability to meet both minimum and maximum mounting height requirements. When using wall-mounted modular multi-metering equipment, make sure multi-metering modules with different capacity ratings are capable of meeting mounting height requirements.
- 308.37 Prior to the installation of meters in a multi-meter installation, the meter sockets shall be permanently identified in a manner which will designate the store, apartment, or other unit being metered. Once identified, the meters will be read to measure consumption according to the original identification and the Utility will not be responsible for any billing errors due to improperly identified meter sockets unless prior written notice has been provided to the Utility of the change of identification.
- 308.38 Each meter socket position and each respective meter disconnect device shall be clearly and permanently identified by the customer to indicate the particular location supplied by it. The relation of the socket, breaker, and dwelling served shall be easily discernible.
- 308.39 In addition to identification of the meter socket and related meter disconnect, there shall be corresponding labeling for each store, apartment or other unit being metered. The corresponding labeling shall exactly match the words, numbers, and/or letters of the labeling at each respective meter socket. The corresponding labeling shall be installed at or near the entrance of each respective store, apartment, or unit served.
- 308.40 The meter socket labeling and identification and the corresponding labeling and identification will not be considered as complete unless all labeling is permanent in nature.
- 308.41 Examples of permanent marking are: (1) an identification plate (engraved laminated plastic) attached by screws, rivets or a secure adhesive or, (2) commercially available embossed decals designed for this purpose (3-M Scotchcal 220) with a minimum character height of 3/4-inch.
- 308.42 Marking with permanent markers, permanent ink, paint pens, and office style label makers is not an acceptable form of permanent marking. Where decals or labels are used for permanent marking, they shall use an industrial grade adhesive rated for exterior use in cold temperatures and shall be constructed of non-fading material.

SECTION 300 – METERING AND SERVICE EQUIPMENT

308 Multiple Metering Requirements, General

- 308.43 Clear identification is defined as a legible street address, apartment number, unit number, or space number. Both alpha and numeric characters may be used. Business names may be included, but alone do not constitute proper location designations.
- 308.44 Meters will not be installed and the service will not be energized until the marking is complete.
- 308.45 When the plan of a multiple metering installation has been established for a building or structure, any additional meter sockets shall conform to that plan. This means when adding additional equipment, the new equipment shall be similar to existing equipment and shall be used as intended by the manufacturer of the equipment. For example, individual wall-mounted single position meter sockets shall not be added to existing wall-mounted modular or wall-mounted common enclosure multiple metering equipment.
- 308.46 Refer to ML&P Tariff Rule 8.6 (or Chugach Tariff Rule 4.1 within the Chugach service area) for specific details regarding multiple metering.

309 CT Rated Metering Requirements, General

- 309.1 Current Transformer (CT) rated metering is required where the service entrance rating, as determined by the Utility, is greater than 225 amps and/or 480 volts. All services with capacity requirements greater than 225 amps shall use CT rated metering equipment.
- 309.2 The Utility does not use class 320 or class 400 metering. Meter sockets and/or meter panels rated at 320 amperes or 400 amperes are prohibited from use on the Utility's system.
- 309.3 The CT enclosure, CT mounting base or rack, CT rated meter socket, rigid metal conduit and related fittings between the current transformer compartment and the meter socket shall be furnished and installed by the customer.
- 309.4 CT rated meter sockets, CT cabinets, and all associated service entrance equipment, including meter disconnects shall be placed outdoors on the exterior of the building or structure in accordance with Section 302.
- 309.5 The customer shall furnish and install a CT rated meter socket meeting the requirements of Section 605 for each CT rated metering point using wall-mounted equipment.
- 309.6 The customer shall furnish and install a CT cabinet meeting the requirements of Section 614 or 615 for each CT rated metering point using wall-mounted equipment.
- 309.7 The customer shall furnish and install an approved meter disconnect meeting the requirements of Section 306 for each CT rated metering point.
- 309.8 The meter disconnect shall be located downstream from the CT cabinet or compartment. A meter disconnect, service disconnect, or main service disconnect shall not be placed ahead of utility meters under any circumstances or conditions where any of the meter socket positions are for CT rated metering. No customer owned or customer controlled disconnect device shall be installed ahead of CT rated metering. Refer to Subsection 303.4.
- 309.9 CT rated meter socket enclosures shall be bonded to their respective CT cabinets by means of a No. 6 AWG stranded copper conductor, insulated with a green jacket. The No. 6 AWG stranded copper conductor shall be installed in accordance with all applicable articles of the latest revision of the NEC.

SECTION 300 – METERING AND SERVICE EQUIPMENT

309 CT Rated Metering Requirements, General

- 309.10 The conduit connecting the meter socket enclosure and the CT cabinet shall be a direct run without access points such as junction boxes or condulets with access covers. Conduit runs **shall not** exceed twenty-five (25) feet in length. The conduit **shall be** of rigid metal, be one (1) inch or greater inside diameter, and have all bends limited to 270 degrees total. The use of conduit material other than rigid metal for meter wiring is prohibited.
- 309.11 The conduit connecting the meter socket enclosure to the CT cabinet shall land on the lower portion of the meter socket enclosure in one of the factory supplied knockout locations (pre-punched) only. Conduit landed on any other part of the meter socket enclosure **shall not** be acceptable.
- 309.12 CT mounting bases and/or mounting base support brackets shall not obstruct the CT meter wiring. The conduit connecting the CT rated meter socket enclosure to the CT cabinet shall provide a minimum of three (3) inches of clear and unobstructed wiring space on the CT cabinet end of the conduit run.
- 309.13 Customer (load-side) conductors shall not obstruct the CT meter wiring. The customer's (load-side) conductors shall be positioned such that the three (3) inch free wiring space dimension is maintained on the CT cabinet end of the conduit run.
- 309.14 CT rated metering equipment, including CT rated meter sockets, CT cabinets, and meter disconnects, shall be installed in compliance with the clearance and working space requirements of Section 521.
- 309.15 **The preferred mounting height for surface-mounted CT rated meter sockets is sixty-five (65) inches.** The maximum mounting height for surface-mounted CT rated meter sockets is seventy-two (72) inches. The minimum mounting height for surface-mounted CT rated meter sockets is sixty (60) inches. Mounting height is measured from the centerline of the meter socket opening to the finished grade or standing surface immediately in front of the meter.
- 309.16 **The preferred mounting height for post-mounted CT rated meter sockets is fifty (50) inches.** The maximum mounting height for post-mounted CT rated meter sockets is sixty-five (65) inches. The minimum mounting height for post-mounted CT rated meter sockets is forty-two (42) inches. Mounting height is measured from the centerline of the meter socket opening to the finished grade or standing surface immediately in front of the meter.
- 309.17 **The preferred mounting height for wall-mounted CT cabinets on services rated up to 800 amps is seventy (70) inches.** The maximum mounting height for wall-mounted CT cabinets on services rated up to 800 amps is eighty-four (84) inches. The minimum mounting height for wall-mounted CT cabinets on services rated up to 800 amps is sixty-four (64) inches. Mounting height is measured from the top of the CT cabinet to the finished grade or standing surface immediately in front of the CT cabinet.
- 309.18 **The preferred mounting height for wall-mounted CT cabinets on services rated 801 to 1,600 amps is eighty (80) inches.** The maximum mounting height for wall-mounted CT cabinets on services rated 801 to 1,600 amps is eighty-six (86) inches. The minimum mounting height for wall-mounted CT cabinets on services rated 801 to 1,600 amps is seventy-six (76) inches. Mounting height is measured from the top of the CT cabinet to the finished grade or standing surface immediately in front of the CT cabinet.

SECTION 300 – METERING AND SERVICE EQUIPMENT

309 CT Rated Metering Requirements, General

- 309.19 **The preferred mounting height for wall-mounted CT cabinets on services rated 1,601 to 2,500 amps is eighty-four (84) inches.** The maximum mounting height for wall-mounted CT cabinets on services rated 1,601 to 2,500 amps is ninety (90) inches. The minimum mounting height for wall-mounted CT cabinets on services rated 1,601 to 2,500 amps is eighty (80) inches. Mounting height is measured from the top of the CT cabinet to the finished grade or standing surface immediately in front of the CT cabinet.
- 309.20 No wall-mounted CT cabinet shall be installed with the floor or bottom of the enclosure less than sixteen (16) inches above the finished grade or standing surface immediately in front of the cabinet.
- 309.21 Wall-mounted CT cabinets shall be equipped with a hinged front cover for access to the CTs. The hinged front cover shall be lockable and shall meet the locking requirements of Section 305.
- 309.22 Wall-mounted CT cabinets with screw cover front access panels are prohibited from use on the Utility's system.
- 309.23 Wall-mounted CT cabinets configured with a hinged cover main compartment for CT mounting and a screw cover side-gutter compartment for entry of line side service conductors are acceptable for use on the Utility's system. The requirement for the hinged cover only applies to the main compartment.
- 309.24 All single-phase CT service installations up to 800 amps using wall-mounted CT cabinets shall include a CT mounting base meeting the requirements of Section 610 or 611.
- 309.25 All three-phase CT service installations up to 800 amps using wall-mounted CT cabinets shall include a CT mounting base meeting the requirements of Section 612 or 613.
- 309.26 Where CT mounting bases with integral mechanical lugs are used, an 800 amp rated unit is required regardless of the rating of the meter disconnect. An 800 amp rated CT mounting base with integral mechanical lugs provides three (3) conductor landing positions for each of the three (3) phases and three (3) conductor landing positions for the neutral conductors. A 400 amp rated CT mounting base with integral mechanical lugs provides three (3) conductor landing positions for each phase, but only one (1) landing position for the neutral conductors. Therefore, 400 amp rated CT mounting bases with integral mechanical lugs are **prohibited** from use on the Utility's system.
- 309.27 All three-phase CT service installations from 801 amps up to 2,500 amps using wall-mounted CT cabinets shall include a CT mounting base or CT mounting interior with removable bus links and CT supports (mounting provisions) meeting the requirements of Section 623.
- 309.28 CT mounting bases, interiors, or racks shall have an ampacity rating equal to or greater than the service capacity rating.
- 309.29 CT mounting bases, interiors, or racks shall have an AIC rating of not less than 50,000 amps.
- 309.30 The Utility shall supply the CTs. The customer shall be responsible for mounting the CTs. The Utility shall furnish and install the test switch and CT wiring. CTs supplied by the Utility for revenue metering shall not be used for any other purpose. Within the Chugach service area Chugach will install the CTs.

SECTION 300 – METERING AND SERVICE EQUIPMENT

309 CT Rated Metering Requirements, General

- 309.31 CT meter wiring shall not be allowed in the same conduit as service conductors. The conduit connecting the CT rated meter socket enclosure and the CT compartment shall only be used for utility revenue metering.
- 309.32 CTs shall be installed with the white dot or polarity mark (also designated as H1) connected to the source (ML&P) side. In most cases, the CT white dot or H1 shall face up and have ML&P (line-side) service conductors land on top. The white dot or H1 side may only face the customer's (load-side) conductors at the discretion of ML&P line crew foreman installing the service on that particular job.
- 309.33 No connections shall be made in any CT cabinet or compartment to supply any other meter or service.
- 309.34 CT cabinets or compartments **shall not** be used as a junction point to serve other metered circuits.
- 309.35 Except for the Utility's (line-side) conductors supplying the CT compartment and the customer's (load-side) conductors to the meter disconnect device(s), no other conductors or devices shall be installed in, or routed through, the CT compartment.
- 309.36 The customer's (load-side) conductors **shall not** pass over the top of, in front of, or in any way restrict access to the Utility's (line-side) conductors or CTs. Depending on circumstances, a larger CT cabinet or side gutter compartment may be necessary to meet this requirement.
- 309.37 Pad-mounted enclosures with a CT compartment on one side and a service termination compartment on the opposite side are permissible with prior approval from the Utility under certain circumstances and conditions. Contact the Utility's Meter Shop for specific details.
- 309.38 Three-phase CT rated service installations from 201 amps to 800 amps using wall mounted CT cabinets having circumstances that require the customer's (load-side) conductors to exit the CT cabinet through the bottom or floor of the cabinet **shall increase** the minimum CT cabinet width dimension to forty-eight (48) inches.
- 309.39 When using a wall-mounted CT cabinet meeting the requirements of Section 615 for CT service installations from 801 amps to 2,500 amps, particular attention must be paid to the arrangement and placement of the service riser conduits. Depending on side gutter compartment dimensions, the service riser conduits may need to be stacked rather than spread out horizontally along the structure wall in order to land the conduits within the floor of the side gutter compartment.
- 309.40 Wall-mounted CT cabinets utilizing side gutter compartments shall have the service riser conduits for the Utility's (line-side) service conductors land on the floor of side gutter compartment only. Service riser conduits for the Utility's (line-side) service conductors **shall not** land on the floor of the main compartment.
- 309.41 Wire connectors used in conjunction with CT mounting bases on CT rated services rated from 226 amps to 800 amps shall use 2-hole pressure connectors (lugs), either compression type or set-screw type. The wire connector shall lay flat on the terminating facility on which it is mounted. The connector shall not be altered or modified in any way. It is recommended that wire connectors used on CT mounting bases have a main body width of two and one-eighth (2-1/8) inches or less.

SECTION 300 – METERING AND SERVICE EQUIPMENT

309 CT Rated Metering Requirements, General

- 309.42 Wire connectors with a single mounting hole shall not be used on CT mounting bases rated up to 800 amps. One-hole pressure connectors (lugs), either compression type or set-screw type, are prohibited. This requirement applies to both the Utility's (line-side) terminations and customer's (load-side) terminations.
- 309.43 Wire Connector Clearance and Spacing: The 2-hole pressure connectors (lugs), either compression type or set-screw type, used to terminate line-side and/or load-side conductors on CT mounting bases rated up to 800 amps, should not diminish the phase-to-phase clearance or the phase-to-ground clearance. Where clearances are diminished, a minimum clearance of one and one-half (1-1/2) inches **shall be** maintained on phase-to-phase clearances and on phase-to-ground clearances.
- 309.44 Pressure connectors (lugs), either compression type or set-screw type, **shall not** be altered or modified in any way. This requirement applies to the Utility's (line-side) terminations and customer's (load-side) terminations.
- 309.45 Where more than one CT rated metering point is required, the customer shall furnish a wall-mounted pull box with terminating facilities meeting the requirements of Section 609. The wall-mounted pull box shall have an ampere rating equal to, or greater than, the total ampere ratings of all metered circuits served from that pull box. Within the Chugach service area exceptions to this ampere rating requirement are available based on the engineer's, NEC based, service equipment rating. The Utility shall terminate its service conductors in the wall-mounted pull box. The customer shall be responsible for installing conductors from the load-side of the pull box terminating facilities to the line (source) side of each CT mounting base.
- a) The Utility shall allow a maximum of three (3) CT rated metering points to be served in this manner. The total combined ampere rating of the service shall not exceed 1,200 amps. Where more than three CT rated metering points are required or when the total combined ampere rating of the service exceeds 1,200 amps, switchboard service section equipment shall be used. Refer to Section 303 for service ampacity rating details.
 - b) This type of service equipment may also be used where a combination of CT rated metering points and self-contained metering points are required. The total combined ampacity rating of the service shall not exceed 1,200 amps. Refer to Section 303 for service ampacity rating details. No more than six (6) metered circuits shall be permitted and each metered circuit shall have only one (1) meter disconnect device.
 - c) The wall-mounted pull box with terminating facilities shall meet the requirements of Section 609. The CT rated and/or self-contained metering points shall meet the requirements as specified by the applicable Section 500 Installation Guidelines and Specifications and the applicable Section 600 Service Equipment Specifications.

SECTION 300 – METERING AND SERVICE EQUIPMENT

310 Switchboard Service Section Requirements, General

- 310.1 Switchboard service sections, including termination compartments, meter sockets, meter disconnects, and/or main service disconnects, and all related service entrance equipment shall be furnished and installed by the customer.
- 310.2 All switchboards shall meet the requirements of NEMA Standard PB-2, Underwriters Laboratories Standard UL 891 and the latest revision of the National Electrical Code. All sections and devices shall be listed and labeled by an approved testing laboratory.
- 310.3 The maximum supply rating and the maximum section rating of any switchboard service section shall be 4,000 amps. Where customer load requirements exceed 4,000 amps for a single point of delivery, multiple points of delivery will be provided. Contact ML&P's Engineering Division for service applications with load requirements greater than 4,000 amps. Within the Chugach service area the 4,000 amp maximum capacity does not apply to all voltages and load profiles. Consult Chugach Engineering for specific application information when the ampacity rating is greater than 2,000 amps.
- 310.4 Switchboard service sections, including termination compartments, meter sockets, meter disconnects, and/or main service disconnects, and all related service entrance equipment **shall be** placed outdoors on the exterior of the building or structure in accordance with Section 302.
- 310.5 All switchboards shall be housed in a NEMA 3R rated outdoor enclosure meeting the requirements of Section 619.
- 310.6 Switchboard service sections shall be designed and manufactured specifically for terminating the service entrance conductors and for housing the CTs. Additional sections may include the meter disconnect, main service disconnect, and fire pump.
- 310.7 All switchboards shall be hot sequence with the line current first entering the instrument transformers and then the disconnecting means and overcurrent protective devices (meter-switch-fuse sequence). The only exception to this is for multiple metering installations with seven (7) or more meter socket positions.
- 310.8 For each and every CT rated meter in a switchboard service section installation, the customer shall furnish and install a circuit breaker, fused switch, or other approved disconnecting means meeting the requirements of Section 306.
- 310.9 The meter disconnect shall be located downstream from the CT compartment. A meter disconnect, service disconnect, or main service disconnect shall not be placed ahead of utility meters under any circumstances or conditions where any of the meter socket positions are for CT rated metering. No customer owned or customer controlled disconnect device shall be installed ahead of CT rated metering. Refer to Subsection 303.4.
- 310.10 All switchboard service sections shall be "front only accessible" such that all line connections can be made from the front of the switchboard.
- 310.11 All switchboard service section top cover panels, rear cover panels, side cover panels, and front cover panels containing unmetered conductors or bus that can be removed from outside the service section **shall be** sealable or lockable.
- 310.12 Except where otherwise specified in this book, unmetered conductors or bus (utility line-side) and metered conductors or bus (customer load-side) of switchboard service sections **shall not** occupy the same space, conduit, raceway, or compartment.

SECTION 300 – METERING AND SERVICE EQUIPMENT

310 Switchboard Service Section Requirements, General

- 310.13 Unmetered conductors or bus (utility line-side) and metered conductors or bus (customer load-side) of switchboard service sections **shall be** separated by suitable barriers.
- 310.14 Except where otherwise specified in this book, barriers used in switchboard installations to separate unmetered conductors or bus (utility line-side) from metered conductors or bus (customer load-side) shall be constructed from sixteen (16) gauge (minimum thickness) steel and shall be secured with devices that are not removable from either the metered sections or the exterior of the switchboard. The barriers, where removable, shall only be removable from the unmetered or utility side.
- 310.15 For the purposes of Section 310, the definition of unmetered conductors or bus are any and all conductors or bus ahead of or upstream from the Utility's metering point and are also referred to as utility or line-side conductors or bus. The definition of metered conductors or bus are any and all conductors or bus behind or downstream from a utility metering point and are also referred to as customer or load-side conductors or bus.
- 310.16 Barriers used in switchboards to separate unmetered conductors or bus from metered conductors or bus must be OEM provided and installed by the switchboard manufacturer. Where barriers in switchboards require modification, the modification shall be an OEM field retrofit kit provided by the switchboard manufacturer. Modifications to switchboard barriers may be subject to field review by an authorized representative from an approved testing laboratory.
- 310.17 Except where otherwise specified in this book, no sealing and/or locking provisions for securing unmetered conductors or bus may be placed behind any door or panel or concealed from view in any manner.
- 310.18 All sealing and locking provisions for switchboard service sections must be OEM, provided and installed by the manufacturer or be an OEM field retrofit kit provided by the manufacturer. All switchboard service sections shall meet the requirements of Section 305. Sealing and locking provisions provided by a third party manufacturer **are not** acceptable.
- 310.19 CT compartments in switchboard service sections shall have hinged front cover access doors (hinged meter panel and hinged blank panel) meeting the requirements of Section 618. The hinged meter panel and hinged blank panel which comprise the front cover access doors for the CT compartment **shall be** lockable and shall accept a padlock with a shackle diameter of not less than five-sixteenths (5/16) inch.
- 310.20 Locking provisions for the 15-inch hinged meter panel and its corresponding hinged blank panel shall be OEM, provided and installed by the switchboard manufacturer. Field retrofitting and field fabrication of locking provisions for these panels **is not** acceptable.
- 310.21 The CT compartment size for switchboards rated from 201 amps to 1,000 amps shall have minimum dimensions meeting the requirements of Section 620.
- 310.22 The CT compartment size for switchboards rated from 1,001 amps to 3,000 amps shall have minimum dimensions meeting the requirements of Section 621.
- 310.23 The CT compartment size for switchboards rated from 3,001 amps to 4,000 amps shall have minimum dimensions meeting the requirements of Section 622.

SECTION 300 – METERING AND SERVICE EQUIPMENT

310 Switchboard Service Section Requirements, General

- 310.24 CT mounting provisions for switchboards rated from 1,001 amps to 3,000 amps shall be designed with removable bus links and CT support brackets meeting the requirements of Section 623 or 624. CT mounting provisions for switchboards rated from 3,001 amps to 4,000 amps shall be designed with removable bus links and CT support brackets meeting the requirements of Section 624.
- 310.25 Switchboard service sections shall be configured so that the CTs, when mounted in the CT compartment of the switchboard, shall be no less than forty-eight (48) inches and no more than seventy-two (72) inches above the standing surface immediately in front of the switchboard.
- 310.26 Switchboard service section busses shall be adequately supported in the CT compartment to withstand the mechanical stresses of short circuit conditions. The bus supports shall not interfere with installation or removal of CTs. CTs shall not be used to support the busses; the busses shall be entirely self-supporting.
- 310.27 CT meter secondary wiring **shall not** occupy the same space, conduit, raceway, or compartment as metered conductors or bus except for metered bus exiting a CT compartment.
- 310.28 The switchboard service section shall be equipped with a 15-inch hinged meter panel meeting the requirements of Section 618.
- 310.29 When two or more switchboard service sections are supplied from one set of service conductors, the supply conductors serving these switchboards shall be terminated ahead of and outside of the metering transformer compartments in a separate sealable enclosure. The supply conductors are to be arranged so they are readily accessible without disturbing the metering transformers and associated secondary wiring.
- 310.30 All switchboard service sections shall have underground service termination compartments meeting the requirements of either Section 625 or 626.
- 310.31 All switchboard service sections shall have underground service termination facilities meeting the requirements of Section 627.
- 310.32 The Utility will supply the CTs. The customer shall be responsible for mounting the CTs. ML&P will furnish and install the test switch and CT wiring. Within the Chugach service area Chugach will install the CTs, test switch and CT wiring.
- 310.33 CTs **shall be** installed with the white dot or polarity mark (also designated as H1) connected to the ML&P (source) side. The CT white dot may face up or down depending on the configuration of switchboard bussing, but shall face the ML&P (source) side.
- 310.34 CTs supplied by ML&P for its revenue metering **shall not** be used for any other purpose.
- 310.35 Customer supplied CTs and/or power monitoring meters will not be allowed in any section, space, raceway, or compartment occupied by unmetered conductors or bus (utility line-side).
- 310.36 Metered conductors or bus (customer load-side) **shall not** be rerouted through a CT compartment. Un-metered conductors or bus (utility line-side) and metered conductors or bus (customer load-side) **shall not** occupy the same conduit, raceway, or wiring gutter.

SECTION 300 – METERING AND SERVICE EQUIPMENT

310 Switchboard Service Section Requirements, General

- 310.37 Switchboard service sections shall be placed on a concrete pad suitably configured for delivery of electric service from the Utility. All specifications related to barriers and separation of unmetered conductors or bus (utility line-side) and metered conductors or bus (customer load-side) of switchboard service sections shall extend to the concrete pad; unmetered conductors or bus (utility line-side) and metered conductors or bus (customer load-side) shall not occupy the same space, conduit, raceway, or compartment.
- 310.38 The maximum mounting height for a switchboard service section CT rated meter socket is seventy-two (72) inches. The minimum mounting height for a switchboard service section CT rated meter socket is fifty-seven (57) inches. Mounting height is measured from the standing surface immediately in front of the meter socket.
- 310.39 The maximum mounting height for self-contained meter sockets in multi-meter switchboard service sections is seventy-five (75) inches. The minimum mounting height for self-contained meter sockets in multi-meter switchboard service sections is thirty-three (33) inches. Mounting height is measured from the centerline of the meter socket opening to the standing surface immediately in front of the meter sockets. The 75-inch maximum height applies to the uppermost socket opening and the 33-inch minimum height applies to the lowermost socket opening of the multi-metering equipment.
- 310.40 The height of the concrete pad must be considered when determining meter socket height. If necessary, the concrete pad may need to be extended out to a minimum of thirty-six (36) inches from the front edge of the switchboard service section in order to provide a proper standing surface and working space and to comply with meter socket height requirements.
- 310.41 Switchboard service sections shall meet the working space and clearance requirements of Section 521.
- 310.42 Service riser conduits for entry of the Utility's (line-side) service conductors into switchboard service sections shall have ninety (90) degree, 24-inch minimum radius, conduit elbows (rigid metal conduit only) and each conduit shall extend out from the switchboard service section's concrete mounting pad no less than twelve (12) inches and no more than forty-eight (48) inches. The size and quantity are to be specified by the Utility Engineering Division.
- 310.43 Service riser conduits for entry of the Utility's (line-side) service conductors into switchboard service sections shall have the conduits placed within the switchboard's concrete mounting pad such that the conduits come up under the appropriate service termination section. Service riser conduits of switchboard service sections shall be placed under no compartment other than the service termination section or compartment. All switchboard service section specifications related to barriers and separation of unmetered conductors or bus (utility line-side) and metered conductors or bus (customer load-side) include the concrete mounting pad and the service riser conduits. This may necessitate stacking of conduits.
- 310.44 Hinged outer doors, hinged meter panels, and screw cover compartment panels **shall be** properly aligned and adjusted for ease of operation. Doors and panels that require pounding, hammering, and/or prying to remove and or re-install are **not** acceptable. The Utility will not energize switchboard service sections until it has been demonstrated that all doors and panel covers operate in an appropriate manner.

SECTION 300 – METERING AND SERVICE EQUIPMENT

311 High Voltage (Primary) Metering Requirements, General

- 311.1 High voltage instrument transformers and instrument transformer-type meters are required for customers taking service at primary voltage under provisions of the Utility's Tariff.
- 311.2 The primary voltages available in the Utility's service area are listed in Section 202. All voltages listed may not be available at all locations or for all loads. Contact the Utility's Engineering Division to determine primary voltage availability.
- 311.3 The Utility's Engineering Division shall be consulted before construction begins to review the requirements of Section 302 and to clarify details related to the Utility's electric distribution system, the customer's proposed high voltage equipment, the point of delivery, and high voltage metering and service equipment requirements.
- 311.4 High voltage metering installations shall follow the equipment arrangement of meter-switch-fuse as stated in Subsection 303.4.
- 311.5 In most cases, the Utility will furnish and install high voltage metering cabinets, current transformers, voltage transformers, meter sockets, meters and all related meter secondary wiring.
- 311.6 The customer shall furnish and install an approved high voltage service disconnect meeting the requirements of Section 306.
- 311.7 The customer may be required to furnish and install an approved high voltage termination enclosure between the high voltage metering point and the high voltage service disconnect.
- 311.8 In most cases, the customer shall furnish and install approved overcurrent protection on that part of the high voltage circuit between the high voltage metering cabinet and the customer's loads, the purpose of which is to protect the Utility's distribution system from fault conditions on the customer's high voltage system.
- 311.9 In most cases, the Utility will furnish and install the conductors from the high voltage metering cabinet to the customer's high voltage service disconnect or to a customer-furnished high voltage termination enclosure between the primary metering enclosure and the customer's high voltage service disconnect.
- 311.10 The customer's high voltage service disconnect or high voltage termination enclosure shall have terminating facilities for the Utility's high voltage service conductors approved by the Utility's Engineering Division.
- 311.11 The customer's high voltage service disconnect shall be conspicuously and permanently marked (with numbers/letters/symbols) to facilitate identification by the Utility's employees. No customer-owned high voltage service disconnect identification or high voltage termination enclosure identification shall duplicate any of the Utility's letters, numbers, or symbols used on its electric distribution system.
- 311.12 In most cases, the point of delivery will be at the customer's high voltage service disconnect enclosure where the Utility's high voltage conductors terminate.
- 311.13 Where high voltage metering cabinets, termination enclosures, disconnect enclosures, or overcurrent protection enclosures are provided by the customer and used by ML&P for terminating, connecting, disconnecting, or re-connecting any of ML&P high voltage cables, conductors, or wires, such customer-provided equipment shall meet the applicable parts of the latest revision of ML&P Material Specifications MU-30, MU-38, MU-43, MU-44, MU-45, and MU-46 (or within the Chugach service area the customer provided equipment shall meet the current Chugach material specification).

SECTION 300 – METERING AND SERVICE EQUIPMENT

311 High Voltage (Primary) Metering Requirements, General

- 311.14 The customer's high voltage system and all related equipment are subject to the NEC. The Utility will require an electrical inspection by the MOA (or the State of Alaska outside of the MOA inspection area and within the Chugach service area) prior to energizing a new high voltage service installation or prior to cutting over to new parts of an upgraded high voltage service installation.
- 311.15 Electrical generators and transfer equipment installed on the customer's system are subject to and shall meet the requirements of Section 212.

312 Load Control and Pulse Metering

- 312.1 The Utility encourages the use of load leveling control equipment by the customer since it can relieve distribution and transmission facilities of unnecessary peak loadings. Additionally, as power costs increase, controlled loads may become desirable in the long term, both for the customer and the Utility.
- 312.2 The Utility will install a meter with a pulse initiator in order to provide pulses for customer use. The cost of this installation in excess of the cost of a standard meter installation shall be paid by the customer.
- 312.3 The customer shall bring control wiring to the termination enclosure and the Utility's personnel will make the final connections. The customer shall not tamper with the Utility's metering installation and shall be liable for disconnection of service pursuant to cases of tampering. The customer shall notify the Utility whenever a malfunction in the metering installation appears to exist.
- 312.4 The Utility will proceed with installation of the metering subject to equipment/parts availability. The customer will be notified should the installation be delayed. In cases of parts unavailability, either for a new installation or repair, the Utility will provide a standard metering installation until the necessary equipment becomes available.

313 Meter Testing

- 313.1 Upon request by a customer, the Utility will test an electric meter. If the test results demonstrate that the meter varies more than two percent from the 100% accuracy standard as determined by the State of Alaska, the test will be performed at the Utility's expense. If the meter does not vary from the standard tolerance, a charge will be made to the customer requesting the test in accordance with the Schedule of Fees and Charges contained in the Utility's Tariff. The meter test will be conducted during normal business hours and, if requested, in the presence of the customer.

SECTION 300 – METERING AND SERVICE EQUIPMENT

314 Fire Alarm and Fire Pump Equipment

- 314.1 The Utility acknowledges NEC requirements, permissions, and exceptions regarding fire alarms, fire pump equipment, and fire sprinkler systems. The NEC does allow attachment of such equipment to the supply side of the service disconnecting means. However, the Utility shall not allow or permit any customer equipment to be attached ahead of the Utility's metering equipment.
- 314.2 The Utility views all fire alarms, fire pump equipment, and fire sprinkler systems as non-utility equipment and will not allow circuits serving this equipment to be placed in the CT compartment or service termination section of a switchboard service section. All requirements concerning separation and barriers stated in Section 310 are in effect with respect to fire alarm and fire pump equipment.
- 314.3 If the electric service entrance for a particular building or structure utilizes switchboard service section style equipment, then a separate area outside of sealable sections for attachment of the fire alarm and fire pump equipment conductors needs to be a distinct part of the electrical service entrance equipment design.
- 314.4 ML&P, at its discretion, may allow fire pump equipment to be served from a separate service from the same transformer serving a building or structure. Approval from ML&P's Engineering Division must be obtained prior to service equipment installation. Within the Chugach service area the fire pump/fire alarm equipment load shall be served from the customer service equipment; a separate service will not be provided.
- 314.5 Circuits for fire alarm and fire pump equipment may be installed along with other customer circuits inside of wall mounted CT cabinets as long as such attachment remains on the load (metered) side of the CTs where other customer load conductors are traditionally terminated.

315 Unusual Conditions

- 315.1 The above requirements and specifications are a statement of minimum requirements for most customer metering installations. Requirements and specifications are necessarily subject to additions and changes as new developments and progress may dictate. In doubtful or unusual instances, special considerations will be necessary. The Utility shall be consulted as to any conditions not set forth herein.

SECTION 300 – METERING AND SERVICE EQUIPMENT

RESERVED

SECTION 400 – INSPECTIONS

401 General Information

- 401.1 Prior to connection of electric service, the customer/applicant is required to obtain an electrical inspection from the Municipality of Anchorage (or the State of Alaska for all non-residential and tri-plex or larger multi-residential services outside of the MOA inspection area.) The following type of work will require an inspection tag:
- a) All service installations not previously served by the Utility.
 - b) Service entrance equipment or a meter base assembly that has been replaced upgraded or relocated.
 - c) When service has been disconnected at the Utility's facilities for repair or re-wiring at the customer's building or service location.
 - d) When service to an existing installation has been disconnected for a significant period of time.
 - e) All services disconnected for reasons of safety, hazards, or non-compliance with codes.

402 Electric Service Inspection Requirements

- 402.1 All new electrical work on the customer's side of the meter requires a permit and may be done by either the homeowner or a contractor licensed by the Municipality of Anchorage. Electrical work done by the homeowner on their personal residence does not require a licensed contractor, but does require a permit. Electrical service equipment must be inspected and approved before connection by the Utility. Any inspection performed by Building Safety requires either a permit for new installations or code compliance agreement for existing installations.
- 402.2 Electrical permits or code compliance agreements and/or information about permits, fees, or payment methods may be obtained at the Building Safety permit counter located at 4700 S. Bragaw or by calling the permit counter at 343-8211. Information about electrical codes should be directed to Electrical Plan Review at 343-8333 or to Electrical Inspections at 343-8316.

403 How and When to Call for Inspection

Municipal Inspection Area

- 403.1 The MOA Inspection area includes the entire Anchorage Bowl except portions of the Upper Hillside that include; Stuckagain Heights, Glen Alps, Bear Valley and Potter Heights. All of the ML&P service area is within the MOA inspection area. Refer to the following link for a map of the Anchorage Bowl MOA Building Safety inspection area:
http://www.muni.org/Departments/OCPD/development/BSD/Forms/Building_Safety_SA_8x11.pdf
Contact MOA Building Safety for the specific boundaries that apply to permitting and inspection on the Upper Hillside.
- 403.2 Electrical inspections for services or structures under a permit may be requested by either telephone or fax. Fax inspection request forms are available at the Building Safety permit counter. The fax number is 249-7777. Your fax will be sent directly to the inspector and then added to the permit file. The information must be legible and complete.

SECTION 400 – INSPECTIONS

403 How and When to Call For Inspection

- 403.3 The telephone recorder number is 343-8300. Please speak clearly and give the information in the order requested: 1) permit number, 2) legal description, 3) address of jobsite, 4) contact phone number, 5) alternate contact number, 6) company name, 7) contact name, 8) type of inspection, 7) any additional information, e.g., directions, time, etc. To avoid re-inspection fees, cancel your inspection by phoning Building Safety at 343-8211. Or you can request an inspection online at www.muni.org/bsd and follow the links to On Line Services.
- 403.4 The inspection request line cut off time is 6:00 a.m. Inspection requests made after that time will not be available to the inspector until the following day. It is the responsibility of the permit holder to arrange for access to the structure, service equipment, branch circuit panel boards and the grounding connection at the water supply.
- 403.5 Commercial service inspections are performed when the installation work for line side of the service up to and including the main disconnect or switch gear has been completed.
- 403.6 Residential service inspections are performed during the “wiring rough-in” inspection of the house. The building wiring, as well as the service, must be complete and pass inspection. Building Safety Handout #1 describes the inspection process and is available at the Public Works permit counter.
- 403.7 Service Inspections of occupied structures, occupied structures undergoing repair, or replacement of service equipment will receive inspection priority and the inspector will attempt to schedule inspection times as requested. All electrical work must be completed and the existing service disconnected by the Utility before the inspector will approve the service. The suggested procedure is to schedule a disconnect from the Utility, add the estimated length of time needed to complete the work and request the inspection for that time from Building Safety.
- 403.8 Inspection of Existing Buildings before Reconnecting: Existing buildings that were disconnected from power shall be inspected by the Municipality before they can be reconnected. The customer may elect to have the service inspected for code compliance prior to hiring an electrical contractor. The structure wiring will be inspected for property/life safety violations. A service tag will be issued upon completion of the inspection if passed by the inspector. If the service or structure fails the inspection, a list of required changes will be provided. An electrical permit and/or an electrical contractor may be needed depending on the changes to be made. The inspector will provide directions as to requirements. Arrangements for inspections will be scheduled by the permit counter staff and confirmed by the inspector.

Outside of the Municipal Inspection Area

- 403.9 The areas outside of the MOA inspection area include portions of the Upper Hillside that include Stuckagain Heights, Glen Alps, Bear Valley and Potter Heights, within the Anchorage Bowl, and all areas south of Potter. All of these areas are within the Chugach service area.
- 403.10 For multi-residential triplex and larger buildings and all non-residential buildings, contact the State of Alaska Department of Labor, Mechanical Inspections (907) 269-4925 at P.O. Box 107020, Anchorage, Alaska 99510.
- 403.11 For all single and duplex residential buildings and non-residential load centers, contact Chugach at (907) 563-7494 or toll free (800) 478-7494.

SECTION 500 - INSTALLATION GUIDELINES & SPECIFICATIONS

501 Overhead Services to Buildings or Structures

- 501.1 All applicable requirements and specifications from other sections of this book apply to these installation guidelines and specifications.
- 501.2 Single family residential service installations qualifying under ML&P Rate Schedule 11 or Chugach's Tariff Residential Service classification shall use a residential combination meter panel and service disconnect meeting the requirements of Section 601.
- 501.3 Commercial, industrial, and non-residential service installations shall use a combination safety socket panel with test-block bypass and service disconnect meeting the requirements of Section 602. Refer to Subsection 303.13 for exceptions.
- 501.4 **The preferred mounting height for single position wall-mounted meter panels is sixty-five (65) inches.** The maximum mounting height for single position wall-mounted meter panels is seventy-two (72) inches. The minimum mounting height for single position wall-mounted meter panels is sixty (60) inches. Mounting height is measured from the centerline of the meter socket opening to the finished grade or standing surface immediately in front of the meter.
- 501.5 **Maximum Conductor Length, General:** The maximum length of an overhead service drop will vary depending on the slope or grade of the land, intervening trees or structures, the size of the conductors used, and the height and strength of the customer's service drop support equipment. The maximum service drop lengths listed below are typical. Consult the Utility's Engineering Division for specific details regarding maximum overhead service conductor length. Within the Chugach service area additional service poles and/or guying may be required to meet clearances or structural requirements. The maximum service length is typically limited by voltage regulation requirements.
- 501.6 **Maximum Span Length for Single-Phase Service:** The maximum span length of an overhead single-phase service drop is typically one-hundred (100) feet. Overhead single-phase services rated over 200 amps, in general, shall be fifty (50) feet or less. Refer to Subsection 501.5. Within the Chugach service area longer spans typically require additional service poles and/or guying.
- 501.7 **Maximum Span Length for Three-Phase Applications:** The maximum span length of an overhead three-phase service drop is typically sixty (60) feet. Overhead three-phase services rated over 200 amps, in general, shall be fifty (50) feet or less. Refer to Subsection 501.5 above. Within the Chugach service area longer spans typically require additional service poles and/or guying.
- 501.8 **Service Drop Termination Location:** In order to minimize the strain on supporting structures, the point of service drop attachment on the building or structure shall be located as near to the Utility's serving pole as practical.
- 501.9 Within the ML&P service area where the wall nearest the pole from which the service is to be supplied does not face a street or alley with overhead facilities, or where there is an adjacent lot, contact ML&P's Engineering Division for precise location of the service weatherhead and point of attachment. Within the Chugach service area contact Chugach Engineering to determine the source pole and location to install the service entrance.
- 501.10 The entire overhead service drop shall be free of obstruction from antennas, structures, poles, masts, trees, and vents.
- 501.11 The service weatherhead shall not be located on the exterior face of any wall which is less than three (3) feet from any common property line. Within the Chugach service area all overhead service risers are required to be located on the gable end for installations in Girdwood and all locations south to Cooper Landing.

(Continued on page 54)

SECTION 500 - INSTALLATION GUIDELINES & SPECIFICATIONS

501 Overhead Services to Buildings or Structures

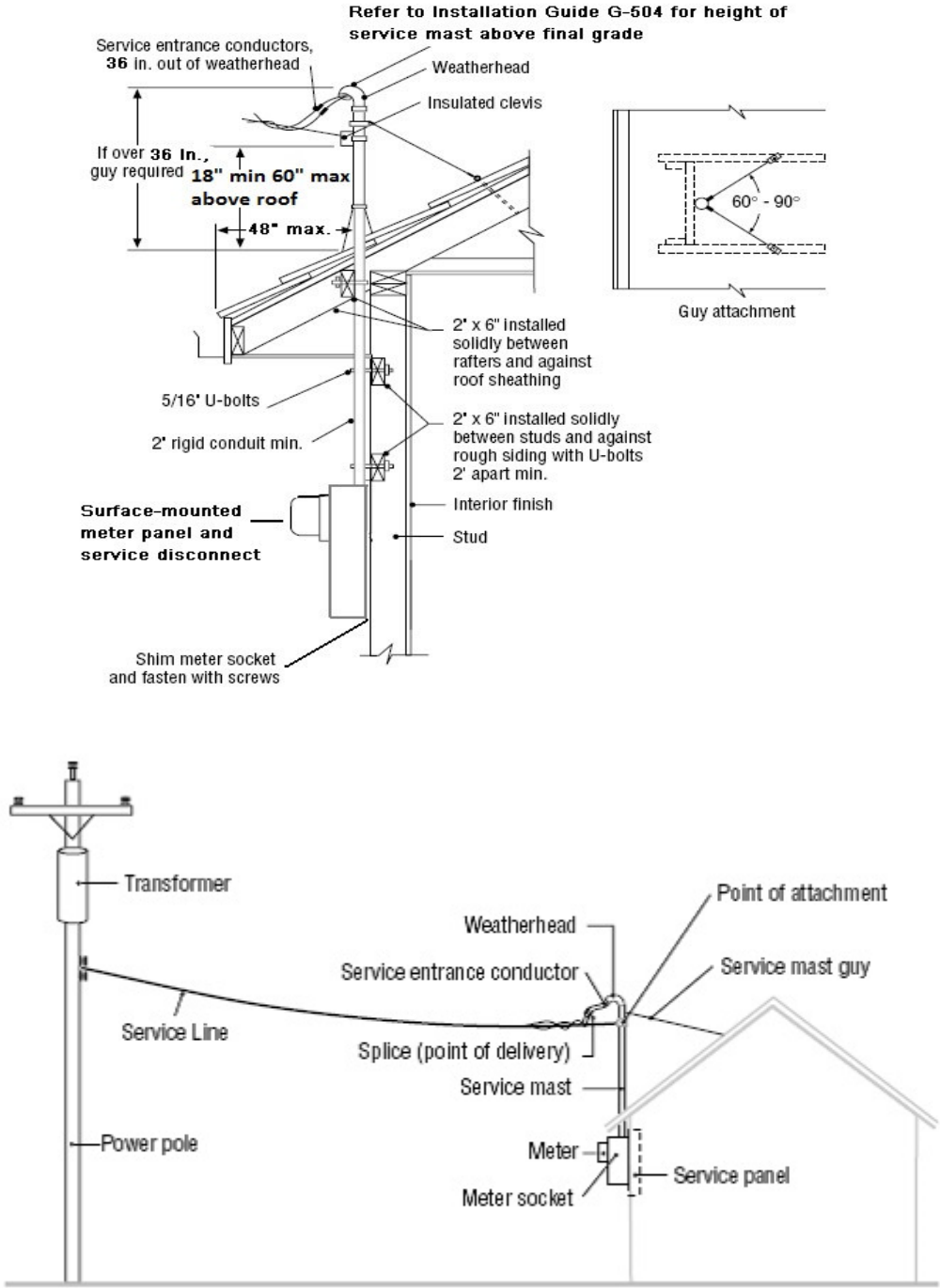

ALL DIMENSIONS SHOWN ARE IN INCHES

SECTION 500 - INSTALLATION GUIDELINES & SPECIFICATIONS

501 Overhead Services to Buildings or Structures

- 501.12 The customer shall furnish and install the service riser (service mast) and extend it to a height sufficient for the Utility to maintain minimum overhead service conductor clearances. Within the Chugach service area the installation of a service pole may be required to meet this requirement depending on service length and topography.
- 501.13 The utility service drop point of attachment on the customer's service riser shall be located in such a manner and extended to a height sufficient for the Utility to maintain compliance with NESC rules for vertical clearance of wires, conductors, and cables above ground, roadway, rail, or water surfaces.
- 501.14 Minimum overhead service conductor clearance requirements shall be based on Section 504.
- 501.15 Periscope type service risers shall be braced or guyed when the distance between the roof surface and the weatherhead exceeds thirty-six (36) inches. The top of the weatherhead shall not extend more than seventy-two (72) inches above the surface of the roof (the maximum conductor attachment height is 60-inches above the roof).
- 501.16 A periscope type service riser shall be located forty-eight (48) inches or less from the edge of the roof line.
- 501.17 The customer shall provide at least thirty-six (36) inches of insulated service conductor out from the weatherhead for the Utility conductor attachment.
- 501.18 The customer shall provide one of the following types of overhead conductor attachment devices:
- a) Thimble eye bolt. Within the Chugach service area a 5/8-inch eyebolt with 2"x 4" square washers installed through the structural stud is required for all gable or wall mount service risers. All hardware shall be hot-dipped galvanized steel.
 - b) Insulated secondary wire holder (house knob), lag screw type. Not approved for Chugach service area.
 - c) Insulated secondary wire holder (house knob), pipe clamp type. Not approved for Chugach service area. Chugach will provide and install the clamp type service deadend on "periscope" risers.
- The overhead service conductor attachment device shall be installed within eighteen (18) inches of the service riser weatherhead. The service conductor attachment device shall be located at a height sufficient for the Utility to maintain minimum service conductor clearances.
- 501.19 The service riser (service mast) shall be rigid metal conduit only and shall have a minimum inside diameter of two (2) inches. Conduit straps attaching the service riser to the building shall be spaced no more than eighteen (18) inches apart.
- 501.20 Conduit straps or conduit strap mounting struts, and meter sockets or meter socket mounting struts shall be anchored to structural components of the building. Attachment to building siding alone is not sufficient.
- 501.21 The customer's neutral wire shall be identified at the weatherhead as either the white or gray wire.
- 501.22 Overhead service installations to buildings or structures shall meet the applicable grounding and bonding requirements of Section 304.

SECTION 500 - INSTALLATION GUIDELINES & SPECIFICATIONS

501 Overhead Services to Buildings or Structures

Single-Family Overhead Service - Mast Guying and Anchoring

If the point of attachment on an unsupported mast exceeds 36", the mast shall be guyed. The figure below shows how an unsupported mast is installed.

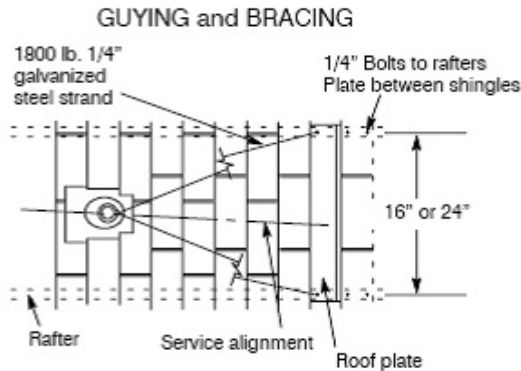

The roof plate must be installed such that the service alignment extension falls within the angle of guys.

PUSH BRACE (OR EQUAL) (2 REQ'D)

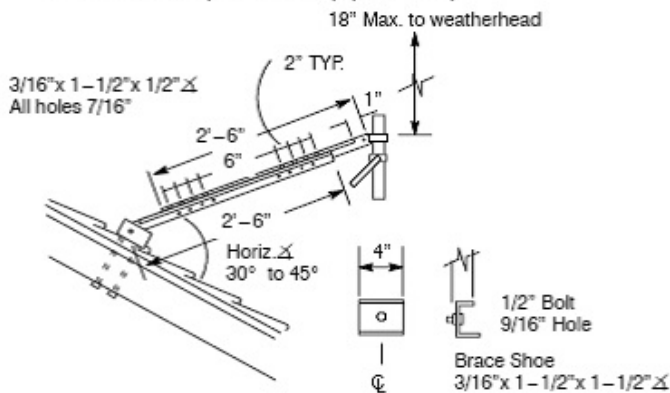

ROOF PLATE (OR EQUAL)

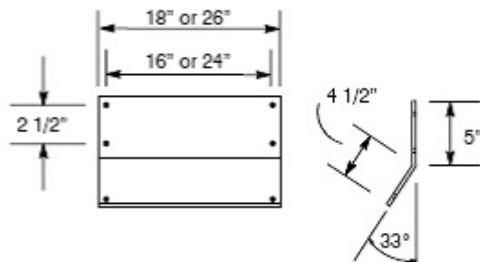

MAST ANCHOR

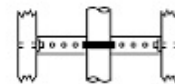

METAL BRACKET (OR EQUAL)



ANCHOR STRAP NO. 1 (OR EQUAL)

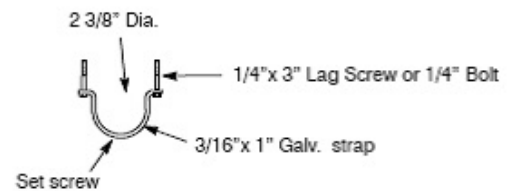

3/8" eye bolts and washers with header block between rafters are acceptable, but eye lags are not acceptable.

ANCHOR STRAP NO. 2 (OR EQUAL)

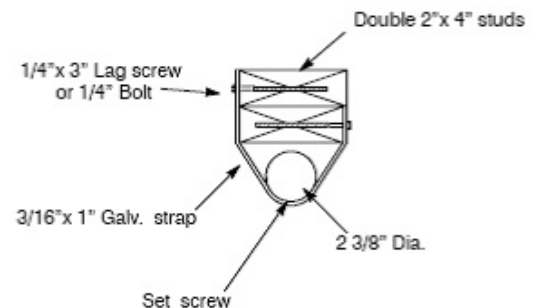

SECTION 500 - INSTALLATION GUIDELINES & SPECIFICATIONS

502 Overhead Services Attached to Poles

- 502.1 All applicable requirements and specifications from other sections of this book apply to these installation guidelines and specifications.
- 502.2 Single family residential service installations qualifying under ML&P Rate Schedule 11 (or the Chugach Tariff Residential Classification within the Chugach service area) shall use a residential combination meter panel and service disconnect meeting the requirements of Section 601.
- 502.3 Commercial, industrial, and non-residential service installations shall use a combination safety socket panel with test-block bypass and service disconnect meeting the requirements of Section 602.
- 502.4 **The preferred mounting height for single position pole-mounted meter panels is sixty-five (65) inches.** The maximum mounting height for single position pole-mounted meter panels is seventy-two (72) inches. The minimum mounting height for single position pole-mounted meter panels is sixty (60) inches. Mounting height is measured from the centerline of the meter socket opening to the finished grade or standing surface immediately in front of the meter.
- 502.5 **Maximum Conductor Length:** The maximum length of a service drop attached to a customer pole is typically fifty (50) feet but may vary depending on the slope or grade of the land, intervening trees or structures, the size of the conductors used, and the height and strength of the customer's service drop support equipment. Consult with the Utility's Engineering Division for specific details regarding overhead service conductor length. Within the Chugach service area the maximum service length is based on the voltage regulation limits. Chugach will install service pole(s) and/or guying to provide the required vertical clearances and to meet strain loading limits of the service attachment. The customer installed pole requires guying where the span length is seventy-five (75) feet or greater.
- 502.6 **Service Drop Termination Location:** In order to minimize the strain on pole mounted service installations, the customer's pole shall be located as near to the Utility's serving pole as practical.
- 502.7 The entire overhead service drop shall be free of obstruction from antennas, structures, poles, masts, trees, and vents.
- 502.8 The customer shall furnish and install the service riser (service mast) and extend it to a height sufficient for the Utility to maintain minimum overhead service conductor clearances.
- 502.9 The utility service drop point of attachment on the customer service riser shall be located in such a manner and extended to a height sufficient for the Utility to maintain compliance with NESC rules for vertical clearance of wires, conductors, and cables above ground, roadway, rail, or water surfaces.
- 502.10 Minimum overhead service conductor clearance requirements shall be based on Section 504.
- 502.11 The customer shall provide a single, un-spliced, self-supporting pole with a minimum diameter of six (6) inches. The 6-inch minimum pole top diameter corresponds to American National Standards Institute (ANSI) O5.1 Pole Class 5 or stronger. The pole shall be rated for ground contact (factory pressure treated preservative).

(Continued on page 58)

SECTION 500 - INSTALLATION GUIDELINES & SPECIFICATIONS

502 Overhead Services Attached to Poles

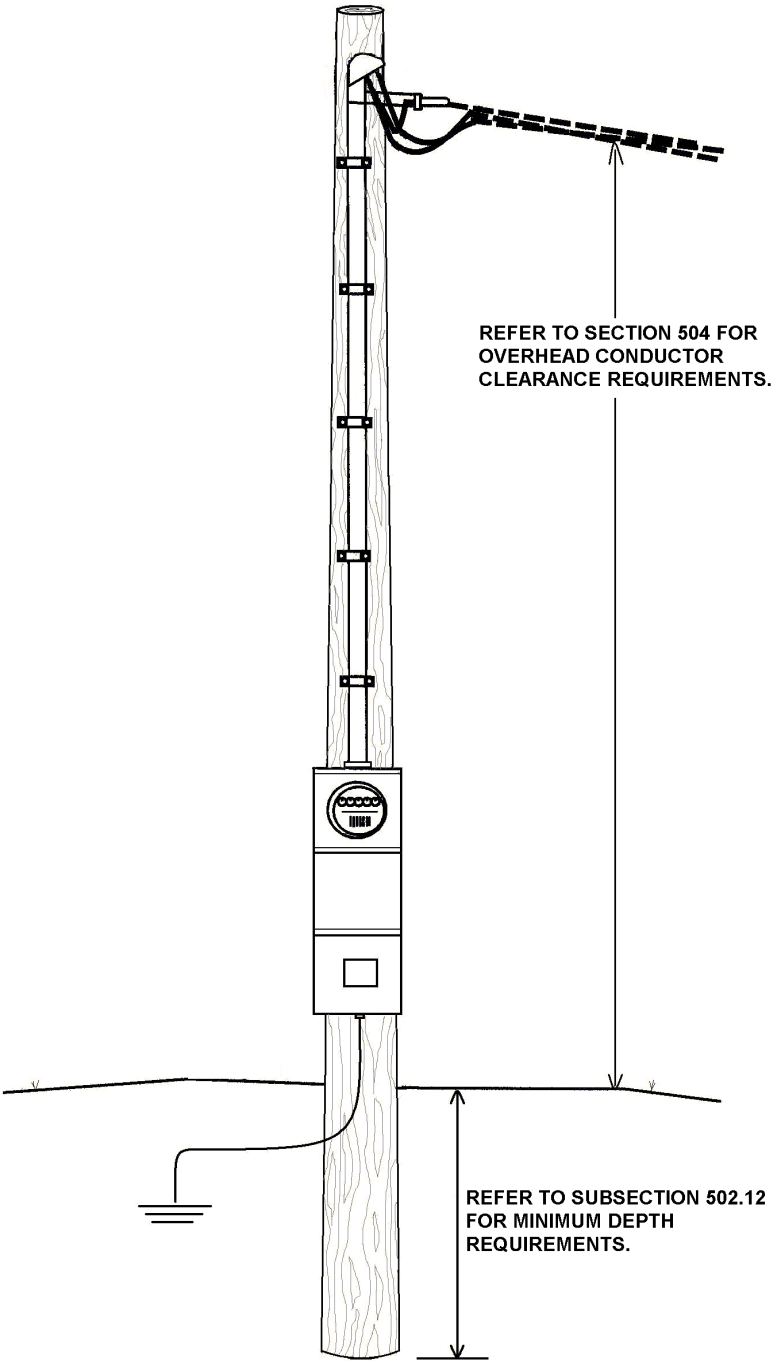

THIS IS A TYPICAL DIAGRAM; IT IS NOT TO SCALE.

SECTION 500 - INSTALLATION GUIDELINES & SPECIFICATIONS

502 Overhead Services Attached to Poles

- 502.12 The pole shall be buried to a minimum depth of sixty (60) inches (for a 30-foot pole) and shall be backfilled and compacted sufficiently to insure that the pole remains level and plumb after service conductors have been attached. Where overhead service conductor clearance requires a service pole greater than thirty (30) feet in height above ground level, burial depth shall be 10% of pole length plus two (2) feet.
- 502.13 The customer shall supply a pole of sufficient length for the Utility to maintain minimum overhead service conductor clearance requirements. The customer shall obtain approval from the Utility's Engineering Division for proper pole height above ground level and shall supply a pole of sufficient length to meet both the sixty (60) inch minimum burial depth and minimum overhead service conductor clearance requirements.
- 502.14 The service riser shall be rigid metal conduit only, and shall have a minimum inside diameter of two (2) inches. Conduit straps attaching the service riser to the pole shall be spaced at least every eighteen (18) inches.
- 502.15 The service riser conduit shall extend to no less than twelve (12) inches below the top of the pole. The service riser conduit shall not extend above the top of the pole. Within the Chugach service area the conductor attachment eyebolt must be mounted eight (8) inches below the top of the pole and no higher than eight (8) inches above the top of the riser.
- 502.16 The customer shall provide one of the following types of overhead conductor attachment devices:
- a) Thimble eye bolt. Within the Chugach service area a 5/8-inch eyebolt with 2"x 4" square washers installed through the structural stud is required for all gable or wall mount service risers. All hardware shall be hot-dipped galvanized steel.
 - b) Insulated secondary wire holder (house knob), lag screw type. Not approved for the Chugach service area.
 - c) Insulated secondary wire holder (house knob), pipe clamp type. Not approved for Chugach service area. Chugach will provide and install the clamp type service deadend when the conduit riser is extended beyond the pole top or it is mounted on uni-strut brackets.
- The service conductor attachment device shall be installed within eighteen (18) inches of the service riser weatherhead. The overhead service conductor attachment device shall be located at a height sufficient for the Utility to maintain minimum service conductor clearances.
- 502.17 The customer's neutral wire shall be identified at the weatherhead as either the white or gray wire.
- 502.18 Overhead service installations attached to poles shall meet the applicable grounding and bonding requirements of Section 304.

SECTION 500 - INSTALLATION GUIDELINES & SPECIFICATIONS

RESERVED

SECTION 500 - INSTALLATION GUIDELINES & SPECIFICATIONS

503 Overhead Temporary Construction Service

- 503.1 All applicable requirements and specifications from other sections of this book apply to these installation guidelines and specifications.
- 503.2 Temporary service is used for the construction of a permanent service and is allowable for up to one (1) year. When temporary service is required for more than one (1) year, the customer must obtain written approval from the Utility's Engineering Division prior to the one (1) year expiration date. If temporary service is required for any purpose other than the construction of a new or upgraded permanent service, the temporary service entrance equipment shall comply with the pertinent requirements for permanent service.
- 503.3 **Maximum Length:** The maximum length of a service drop attached to a customer temporary service post is typically fifty (50) feet but may vary depending on the slope or grade of the land, intervening trees or structures, the size of the conductors used, and the height and strength of the customer's service drop support equipment. Consult with the Utility's Engineering Division for specific details regarding overhead service conductor length. The minimum length of service is ten (10) feet (do not place the post in the path of the permanent service). Within the Chugach service area the customer installed pole requires guying where the span length is seventy-five (75) feet or greater.
- 503.4 **Service Drop Termination Location:** In order to minimize the strain on the temporary service post, it shall be located as near to the Utility's serving pole as practical.
- 503.5 The entire overhead service drop shall be free of obstruction from antennas, structures, poles, masts, trees, and vents.
- 503.6 The customer shall provide a single, un-spliced post with a minimum diameter of five and one-half (5-1/2) inches (6 x 6 dimensional lumber size). The post material shall be rated for ground contact (factory pressure treated preservative).
- 503.7 The customer shall supply a post of sufficient length for the Utility to maintain minimum overhead service conductor clearance requirements.
- 503.8 The customer shall furnish and install the service riser (service mast) and extend it to a height sufficient for the Utility to maintain minimum overhead service conductor clearances.
- 503.9 The utility service drop point of attachment on the customer's service riser shall be located in such a manner and extended to a height sufficient for the Utility to maintain compliance with the NESC rules for vertical clearance of wires, conductors, and cables above ground, roadway, rail, or water surfaces.
- 503.10 Minimum overhead service conductor clearance requirements shall be based on Section 504.
- 503.11 The customer shall construct a self supporting installation. The 6 x 6 post shall be buried to a minimum depth of sixty (60) inches (for a post up to 30 feet), backfilled and compacted sufficiently to insure that the post remains level and plumb after service conductors have been attached. The length of the post shall be sufficient for the Utility to maintain minimum overhead service conductor clearance requirements. The customer shall obtain approval from the Utility's Engineering Division for proper post height.

(Continued on page 62)

SECTION 500 - INSTALLATION GUIDELINES & SPECIFICATIONS

503 Overhead Temporary Construction Service

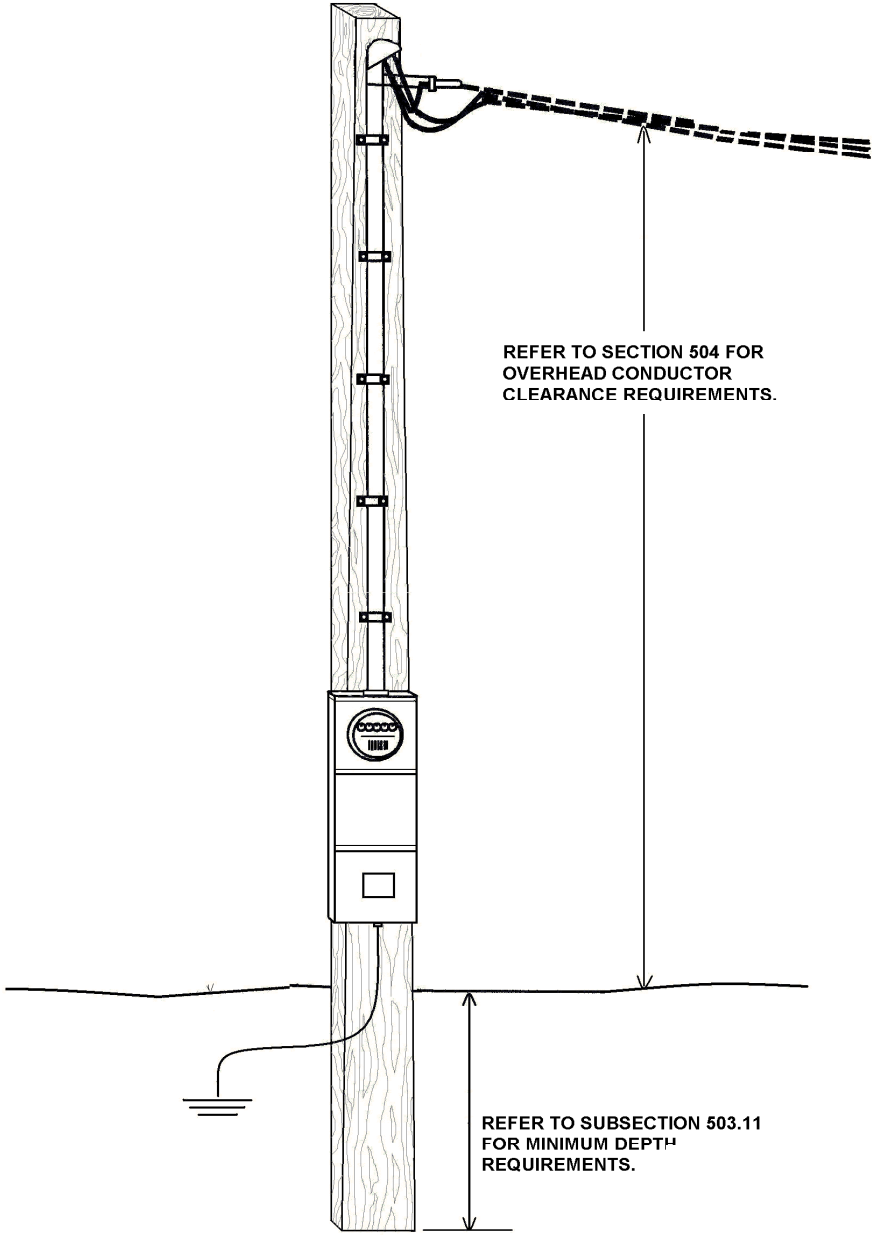

THIS IS A TYPICAL DIAGRAM; IT IS NOT TO SCALE.

SECTION 500 - INSTALLATION GUIDELINES & SPECIFICATIONS

503 Overhead Temporary Construction Service

- 503.12 The service riser shall be rigid metal conduit only and shall have a minimum inside diameter of two (2) inches. Conduit straps attaching the service riser to the post shall be spaced at least every eighteen (18) inches.
- 503.13 The service riser conduit shall extend to no less than twelve (12) inches below the top of the post. The service riser conduit shall not extend above the top of the post. Within the Chugach service area the weatherhead can extend to a maximum of 12-inches above the top of the post.
- 503.14 Meter panels used for the purpose of temporary construction service shall be exempt from the safety socket and test-block bypass requirement on single-phase and network services; a meter panel meeting the requirements of Section 601 may be provided.
- 503.15 Temporary construction service requiring three-phase power shall not be exempt from the safety socket and test-block bypass requirement; a meter panel with the safety socket feature and factory installed test-block/bypass facilities meeting the requirements of Section 602 shall be provided.
- 503.16 **The preferred mounting height for single position temporary overhead post-mounted meter panels is sixty-five (65) inches.** The maximum mounting height for single position temporary overhead post-mounted meter panels is seventy-two (72) inches. The minimum mounting height for single position temporary overhead post-mounted meter panels is sixty (60) inches. Mounting height is measured from the centerline of the meter socket opening to the finished grade or standing surface immediately in front of the meter.
- 503.17 The customer's neutral wire shall be identified at the weatherhead as either the white or gray wire.
- 503.18 The customer shall provide one of the following types of overhead conductor attachment devices:
- a) Thimble eye bolt. Within the Chugach service area a 5/8-inch eyebolt with 2"x 4" square washers installed through the structural stud is required for all gable or wall mount service risers. All hardware shall be hot-dipped galvanized steel.
 - b) Insulated secondary wire holder (house knob), lag screw type. Not approved for the Chugach service area.
 - c) Insulated secondary wire holder (house knob), pipe clamp type. Not approved for Chugach service area. Chugach will provide and install the clamp type service deadend when the conduit riser is extended 12-inches above the top of the post.

The service conductor attachment device shall be installed within eighteen (18) inches of the service riser weatherhead. The overhead service conductor attachment device shall be located at a height sufficient for the Utility to maintain minimum service conductor clearances.

- 503.19 Overhead temporary construction service installations attached to posts shall meet the applicable grounding and bonding requirements of Section 304. At least one ground rod shall be installed on temporary construction service installations. The ground rod shall be placed no more than seventy-two (72) inches from the service disconnect device.

SECTION 500 - INSTALLATION GUIDELINES & SPECIFICATIONS

RESERVED

SECTION 500 - INSTALLATION GUIDELINES & SPECIFICATIONS

504 Overhead Conductor Clearances

- 504.1 The Utility shall maintain overhead service conductor clearances in accordance with the requirements for vertical clearance of wires, conductors, and cables above ground, roadway, rail, or water surfaces as prescribed by the most recent State adopted publication of the NESC. Customers should contact the Utility before placing any structures within ten feet (horizontal groundline measurement perpendicular to the line) of the service conductor or raising the grade or the use of the property.
- 504.2 Customer poles, support structures, and attachment points for overhead service conductors must be of a height sufficient for the Utility to maintain compliance with the NESC vertical clearance requirements.
- 504.3 Following are general and typical overhead clearance requirements for service conductors with phase to ground voltages less than 600 volts (NOTE: these vertical clearances are the minimum requirement under specific temperature and ice loading conditions and are for reference only; see subsection 504.7):
- a) 24-1/2 feet over state highways.
 - b) 18 feet over public streets, alleys, roads, parking areas subject to truck traffic, and driveways on other than residential property. The Utility requires this minimum clearance for new installations crossing over all drivable areas, as determined by the Utility.
 - c) 15 feet over residential property and driveways, and those commercial areas not subject to truck traffic where the phase to ground voltage exceeds 300 volts. For new installations the Utility requires 18-feet (minimum) of clearance over all drivable areas, as determined by the Utility.
 - d) 13 feet over residential property and driveways, and those commercial areas not subject to truck traffic where the phase to ground voltage is less than 300 volts. For new installations the Utility requires 18-feet (minimum) of clearance over all drivable areas, as determined by the Utility.
 - e) 13 feet at the point of service conductor attachment.
 - f) 12 feet at the bottom edge of the drip loop.
 - g) 12 feet above roof with permanent access.
 - h) 4-1/2 feet above roof without permanent access. Within the Chugach service area new installations require 12-feet (minimum vertical clearance) over the roofs of all buildings.
- 504.4 For specific details regarding vertical clearance of wires, conductors, and cables above ground, roadway, rail, and water surfaces, refer to the most recent State adopted publication of the NESC, Part 2. Safety Rules for Overhead Lines, Section 23 Clearances, Tables 232-1 through 232-3, and Table 234-1.
- 504.5 The requirement for vertical clearance of wires, conductors, and cables above ground also extends to the decks or platforms of houses, buildings, or structures. Decks or platforms generally would be considered as spaces and ways subject to pedestrians or restricted traffic only. Within the Chugach service the twelve (12) foot minimum vertical clearance requirement applies to these locations.
- 504.6 The diagrams shown on page 65 denote general and typical overhead clearance requirements for service conductors with phase to ground voltages less than 600 volts.
- 504.7 The diagrams shown on page 65 denote typical clearances based on worst case sag. Clearances may change due to unique circumstances. Consult with the Utility's Engineering Division prior to installing service equipment.

SECTION 500 - INSTALLATION GUIDELINES & SPECIFICATIONS

504 Overhead Conductor Clearances

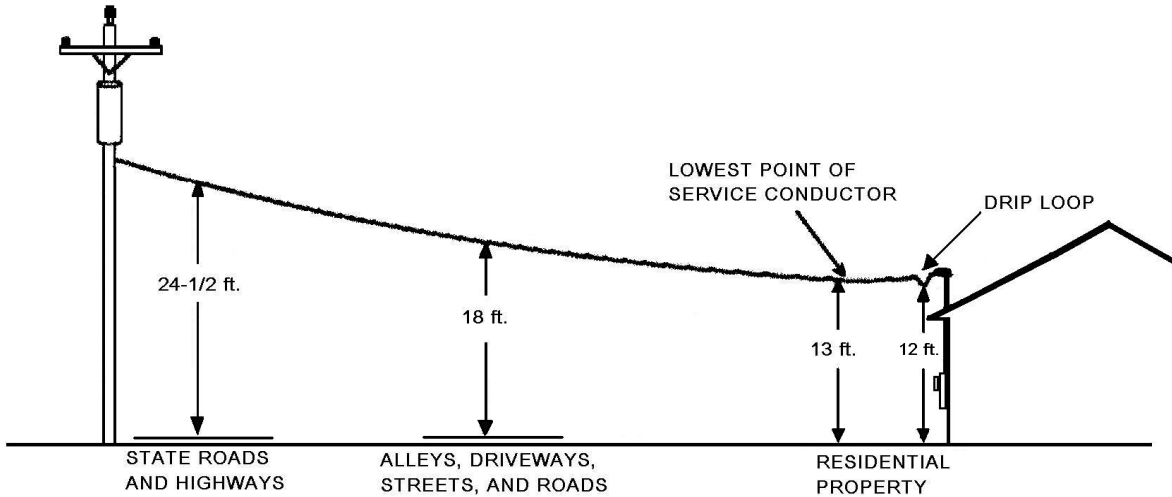

Typical Clearances Based on Worst Case Sag

See Subsection 504.7 for unique circumstances and coordination responsibilities.

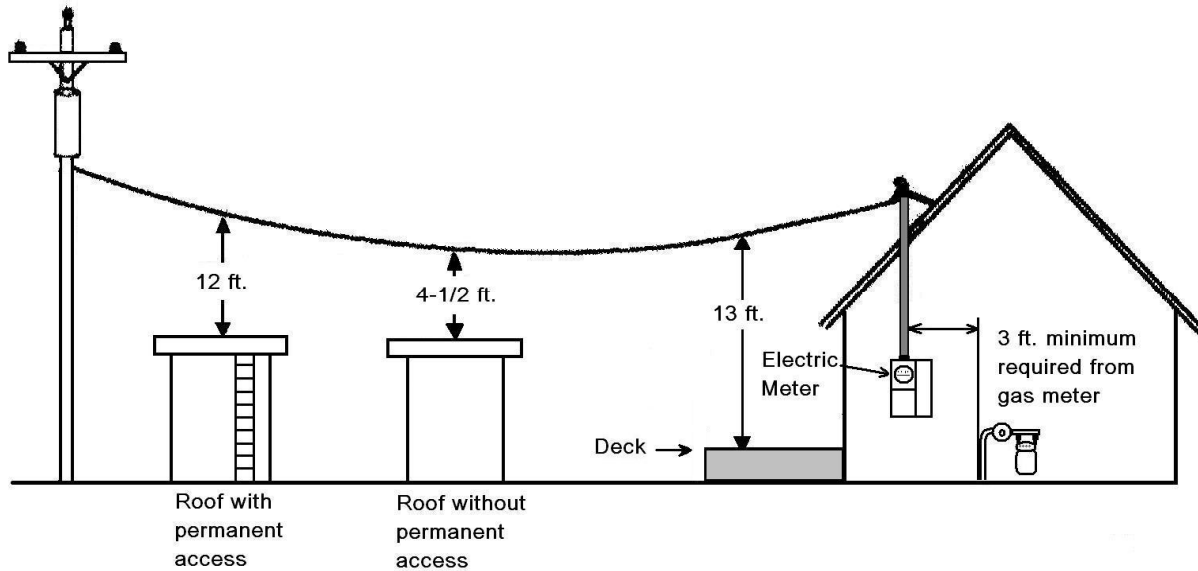

Typical Clearances Based on Worst Case Sag

See Subsection 504.7 for unique circumstances and coordination responsibilities.

Within the Chugach service area the 12 foot clearance applies to roofs without permanent access.

SECTION 500 - INSTALLATION GUIDELINES & SPECIFICATIONS

505 Underground Temporary Construction Service

- 505.1 All applicable requirements and specifications from other sections of this book apply to these installation guidelines and specifications.
- 505.2 Temporary service is used for the construction of a permanent service and is allowable for up to one (1) year. When temporary service is required for more than one (1) year, the customer must obtain written approval from the Utility's Engineering Division prior to the one (1) year expiration date. If temporary service is required for any purpose other than the construction of a new or upgraded permanent service, the temporary service entrance equipment shall comply with the pertinent requirements for permanent service.
- 505.3 Prior to installing temporary service equipment, the customer shall obtain approval from the Utility's Engineering Division for the precise location of the temporary service platform and meter socket. Under most circumstances, the customer-owned service platform shall be located within ten (10) feet of the Utility underground service facilities.
- 505.4 Meter panels used for the purpose of temporary construction service shall be exempt from the safety socket and test-block bypass requirement on single-phase and network services; a meter panel meeting the requirements of Section 601 may be provided.
- 505.5 Temporary construction service requiring three-phase power shall not be exempt from the safety socket and test-block bypass requirement; a meter panel with the safety socket feature and factory installed test-block/bypass facilities meeting the requirements of Section 602 shall be provided.
- 505.6 The customer shall provide a temporary service platform constructed of 2 x 6 dimensional lumber. The platform shall have a minimum length and width of three (3) feet. The upright post for mounting the meter socket shall have as a minimum, a 2 x 10 plank extending up from the platform base at least forty-eight (48) inches. The upright plank shall be of sufficient width to provide backing for the entire meter socket assembly. The upright plank shall be braced on two (2) sides with dimensional lumber, pipe, or conduit.
- 505.7 **The preferred mounting height for post-mounted meter panels is fifty (50) inches.** The maximum mounting height for post-mounted meter panels is sixty-five (65) inches. The minimum mounting height for post-mounted meter panels is forty-two (42) inches. Mounting height is measured from the centerline of the meter socket opening to the finished grade or standing surface immediately in front of the meter.
- 505.8 The service riser conduit shall be liquidtight flexible metal conduit with an inside diameter of two (2) inches, a maximum length of nine (9) feet, and shall include a bushing or ferrule on the open end.
- 505.9 Underground service riser conduits shall extend at least to the edge of the platform where the Utility will connect to it with corflo duct or electrical nonmetallic tubing. The Utility requires a twenty (20)-foot coil of #2 AWG Aluminum Type USE or THHN jacketed conductor connected to the line side lugs of the meter main (200A maximum). The Utility will place the conductor in corflo and connect to the power source. All services 480V line-line or greater require thawing and trenching unless the temporary corflo protected service is located within a fenced, controlled access area or the conductor is placed in HDPE conduit. The Utility will not install corflo across roadways, driveways, or other locations, including easements, subject to vehicles or equipment traffic.

SECTION 500 - INSTALLATION GUIDELINES & SPECIFICATIONS

505 Underground Temporary Construction Service

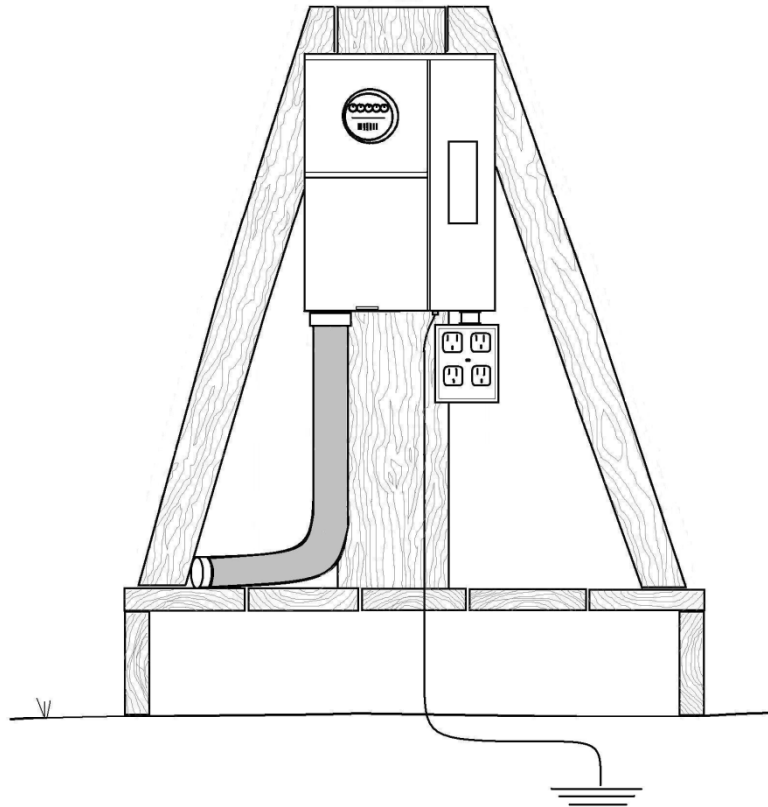

- 505.10 Underground temporary construction service installations shall meet the applicable grounding and bonding requirements of Section 304. At least one ground rod shall be installed on temporary service installations. The ground rod shall be placed no more than seventy-two (72) inches from the service disconnecting device. Within the Chugach service area a 20-foot coil of #6 AWG bare solid copper grounding wire connected to the meter main is required (Chugach will connect to the ground rod at the power source when fed from underground equipment; for overhead sources the customer will install the ground rod).
- 505.11 For underground temporary construction services with load requirements above 200 amps, CT rated temporary services are permissible. Contact the Utility's Meter Shop for details.

SECTION 500 - INSTALLATION GUIDELINES & SPECIFICATIONS

506 Underground Service, Wall-Mounted, Up To 200 Amps

- 506.1 All applicable requirements and specifications from other sections of this book apply to these installation guidelines and specifications.
- 506.2 The customer shall furnish and install a residential combination meter panel and service disconnect or a combination safety socket panel with test-block bypass and service disconnect.
- 506.3 Residential combination meter panels and service disconnects or combination safety socket panels with test-block bypass and service disconnects shall be placed outdoors on the exterior of the building or structure in accordance with Section 302.
- 506.4 Single family residential service installations qualifying under ML&P Rate Schedule 11 (or Chugach's Tariff Residential Classification within the Chugach service area) shall use a residential combination meter panel and service disconnect meeting the requirements of Section 601.
- 506.5 Non-residential, commercial, or industrial service installations shall use a combination safety socket panel with test-block bypass and service disconnect meeting the requirements of Section 602. The Utility exempts the following non-residential applications from the safety socket test bypass requirement: decorative lighting, thaw wires and Lake Hood/Spenard floatplane tie downs.
- 506.6 Self-contained meter sockets used in wall-mounted underground service applications shall meet the general requirements of Section 307.
- 506.7 **The preferred mounting height for single position wall-mounted meter panels is sixty-five (65) inches.** The maximum mounting height for single position wall-mounted meter panels is seventy-two (72) inches. The minimum mounting height for single position wall-mounted meter panels is sixty (60) inches. Mounting height is measured from the centerline of the meter socket opening to the finished grade or standing surface immediately in front of the meter.
- 506.8 Wall-mounted underground service installations, both residential and commercial applications, shall meet the clearance and working space requirements of Section 303 and Section 521.
- 506.9 Wall-mounted underground service installations shall meet the applicable grounding and bonding requirements of Section 304.
- 506.10 Meter panels or meter panel mounting struts, and conduit mounting straps or conduit strap mounting struts shall be anchored to structural components of the building. Attachment to plywood siding, aluminum siding, or light gauge steel siding **is not** acceptable. Attachment to heavy gauge steel siding may be acceptable where the steel siding is at least 16 gauge.
- 506.11 The customer shall furnish and install service riser conduits for the Utility's (line-side) service conductors meeting the general requirements of Section 520.
- 506.12 Service riser conduits for wall-mounted non-residential, commercial, or industrial service installations shall be rigid metal conduit.
- 506.13 Service riser conduits for wall-mounted single position meter sockets used in residential applications shall be liquidtight flexible metal conduit with an inside diameter of two (2) inches, a maximum length of nine (9) feet, and shall include a bushing or ferrule on the open end. The flexible metal conduit riser connection requires the use of one of the three following methods: 1) an insulated grounding bushing with two 3-1/2" x 2" reducing washers, sandwiching the enclosure floor 2) a 4-bolt threaded hub or 3) an insulated grounding bushing with a 2-inch drilled hole through bottom of enclosure without a knockout provision.

SECTION 500 - INSTALLATION GUIDELINES & SPECIFICATIONS

506 Underground Service, Wall-Mounted, Up To 200 Amps

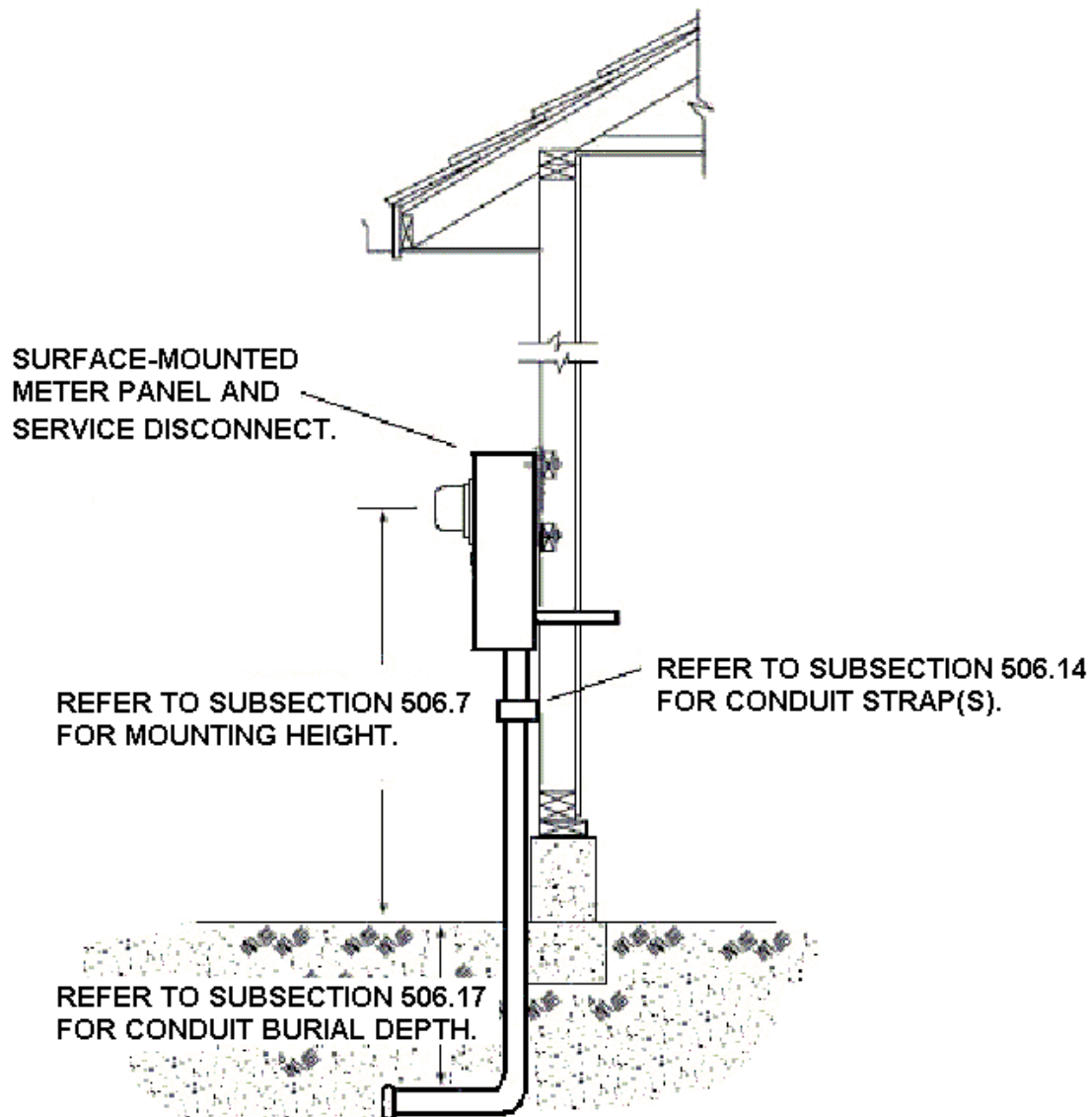

- 506.14 Service riser conduits shall be secured in place. Service riser conduits shall be anchored to the building or structure with a minimum of one (1) conduit strap or clamp (24-inch minimum spacing required for rigid steel risers).
- 506.15 Service riser conduits for entry of the Utility's (line-side) service conductors into terminating pull sections or compartments shall include 90-degree, 24-inch minimum radius conduit elbows (rigid metal conduit only) to transition from the horizontal part of the conduit run to the vertical part of the conduit run.
- 506.16 The horizontal section of each service riser conduit shall extend out from the terminating pull section or compartment a minimum of twelve (12) inches and no more than forty-eight (48) inches from the pull section or compartment on which it is landed.
- 506.17 Except where otherwise specified in this book, the horizontal section of each service riser conduit shall be placed so that the top of the conduit is twenty-four (24) inches below finished grade. Within the Chugach service area the minimum burial depth is thirty (30) inches.

SECTION 500 - INSTALLATION GUIDELINES & SPECIFICATIONS

507 Underground Service, Post-Mounted, Up To 800 Amps

- 507.1 All applicable requirements and specifications from other sections of this book apply to these installation guidelines and specifications.
- 507.2 Post-mounted underground service installations may be configured as single position self-contained metering points, multiple metering points with a maximum of six (6) meter socket positions, or CT rated metering points up to 800 amps in service capacity. Where more than six (6) meter socket positions are required or where the service capacity exceeds 800 amps, the appropriate wall-mounted or pad-mounted installation guideline(s) and specification(s) shall apply.
- 507.3 The customer shall furnish and install an equipment mounting post or posts, meter panel, meter disconnect, and service riser conduit mounting provisions, the required number of meter sockets, the required number of meter disconnects, a CT cabinet or a wall-mounted pull box as required.
- 507.4 Where a single position meter installation is required, the applicable parts of Section 506 shall apply.
- 507.5 Single family residential service installations qualifying under ML&P Rate Schedule 11 (and Chugach's Tariff Residential Classification within the Chugach service area) shall use a residential combination meter panel and service disconnect meeting the requirements of Section 601. Within the Chugach service area non-typical residential service entrance locations require prior approval by Chugach Engineering. Service entrances at any location on the residential structure, other than within three (3) feet from the corner of the structure that is closest to the power source designated by Chugach are non-typical. Residential post mounted (remote) meter base installations require prior approval by Chugach of a location within thirty (30) feet of the residence structure's typical service entrance location, outside of the utility easement and on the customer's property within the normal service alignment (based on the typical structure mounted meter location). A permanent sign (8" x 5" minimum) shall be attached to an unobstructed surface of the building nearest to the power source (the typical service location) and five (5) to six (6) feet above final grade. The sign shall be labeled "REMOTE ELECTRIC METER DISCONNECT located 00 ft south/north and 00 ft east/west." The installer shall substitute the actual distances and bearing directions (accurate to within five feet). The background color for the sign shall provide sufficient contrast with the siding color to be recognizable at a distance of ten feet in daylight and the lettering legible at three feet. Refer to 308.41 and 308.42 for additional signage requirements.
- 507.6 Commercial, industrial, and non-residential service installations rated 200 amps or less shall use a combination safety socket panel with test-block bypass and service disconnect meeting the requirements of Section 602. Within the Chugach service area non-residential post mounted service is required to be located within 15-feet, but no closer than ten (10)-feet to the power source (the post mounted service location must be approved by Chugach Engineering in advance of installation).
- 507.7 Where multiple metering is required, the applicable parts of Section 509, 510-A, or 510-B shall apply.
- 507.8 Self-contained meter sockets used in post-mounted underground service applications shall meet the general requirements of Section 307.

(Continued on page 72)

SECTION 500 - INSTALLATION GUIDELINES & SPECIFICATIONS

507 Underground Service, Post-Mounted, Up To 200 Amps

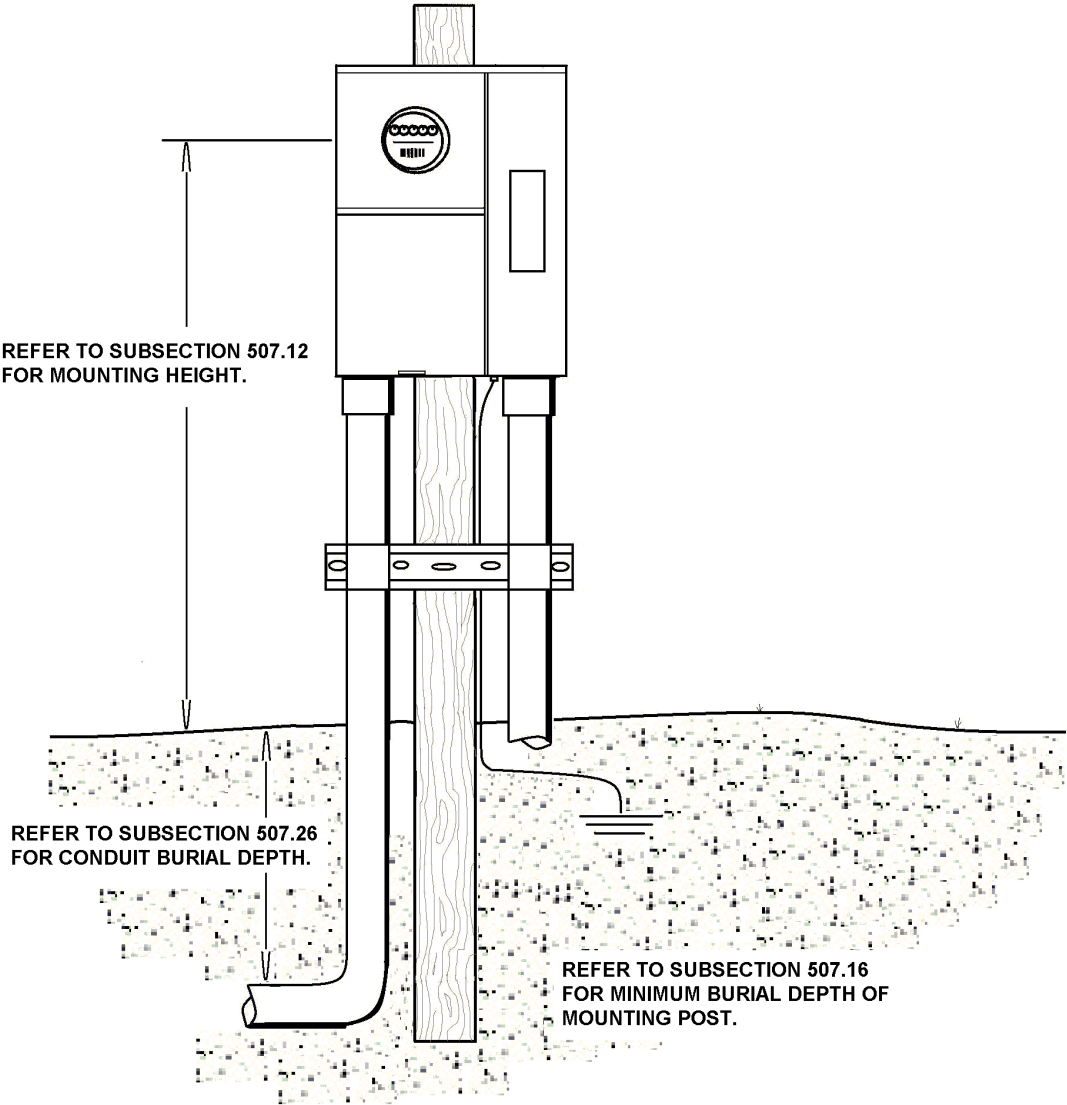

THIS IS A TYPICAL DIAGRAM; IT IS NOT TO SCALE.

SECTION 500 - INSTALLATION GUIDELINES & SPECIFICATIONS

507 Underground Service, Post-Mounted, Up To 800 Amps

- 507.9 Where CT rated metering is required, the applicable parts of Section 514 or Section 515 shall apply.
- 507.10 CT service installations rated from 201 amps to 800 amps, using post-mounted equipment, shall meet the general requirements of Section 309.
- 507.11 Post-mounted underground service installations, both residential and commercial applications, shall meet the clearance and working space requirements of Section 303 and Section 521.
- 507.12 **The preferred mounting height for post-mounted meter panels is fifty (50) inches.** The maximum mounting height for post-mounted meter panels is sixty-five (65) inches. The minimum mounting height for post-mounted meter panels is forty-two (42) inches. Mounting height is measured from the centerline of the meter socket opening to the finished grade or standing surface immediately in front of the meter.
- 507.13 The customer shall provide a single, un-spliced, self-supporting post or posts with a minimum diameter of six (6) inches and with a length sufficient to meet both minimum depth burial requirements and minimum meter socket height requirements.
- 507.14 Where wood posts are used, the wood shall be treated and rated for ground contact (factory pressure treated preservative).
- 507.15 Where steel posts are used, the steel shall be galvanized or have a similar approved coating to prevent corrosion. Where steel posts are used, the minimum diameter may be reduced to four (4) inches (steel posts must be capped).
- 507.16 The post shall be buried to a minimum depth of forty-eight (48) inches, backfilled and compacted sufficiently to insure that the post remains level and plumb after the meter and service conductors have been installed (steel posts require a concrete backfilled foundation).
- 507.17 The single un-spliced post or posts shall extend at minimum to the top edge of the service equipment mounted upon it. The post or posts shall extend no more than eighteen (18) inches above the top edge of the service equipment mounted upon it.
- 507.18 Mounting provisions for meter panels, meter sockets, meter disconnects, multi-meter enclosures, CT cabinets, or wall-mounted pull boxes may be constructed of wood or steel. Where wood is used for equipment mounting, it shall be factory pressure preservative treated. Where steel is used for equipment mounting, it shall be galvanized or have a similar approved coating.
- 507.19 Post mounted service installations shall be constructed to provide service equipment support equivalent to that of wall-mounted equipment. Post mounted equipment that has excessive bending, bowing, flexing, or twisting **is not** acceptable and will not be approved.
- 507.20 Post-mounted underground service installations shall meet the applicable grounding and bonding requirements of Section 304. Where ground rods are used as part of the grounding electrode system, they shall be placed a minimum of thirty-six (36) inches from any of the Utility underground conductors, pad-mounted transformers, or poles.
- 507.21 The customer shall furnish and install service riser conduits for the Utility's (line-side) service conductors meeting the general requirements of Section 520.

SECTION 500 - INSTALLATION GUIDELINES & SPECIFICATIONS

507 Underground Service, Post-Mounted, Up To 800 Amps

- 507.22 Service riser conduits for all post-mounted service installations shall be rigid metal conduit. Liquidtight flexible metal conduit **shall not** be used in post-mounted service applications.
- 507.23 Service riser conduits shall be secured in place. Service riser conduits shall be anchored to the post or posts with a minimum of one (1) conduit strap or clamp (24-inch minimum clamp spacing).
- 507.24 Service riser conduits for entry of the Utility's (line-side) service conductors into terminating pull sections or compartments shall include 90-degree, 24-inch minimum radius conduit elbows (rigid metal conduit only) to transition from the horizontal part of the conduit run to the vertical part of the conduit run.
- 507.25 The horizontal section of each service riser conduit shall extend out from the terminating pull section or compartment a minimum of twelve (12) inches and no more than forty-eight (48) inches from the pull section or compartment on which it is landed.
- 507.26 Except where otherwise specified in these service requirements, the horizontal section of each service riser conduit shall be placed so that the top of the conduit is twenty-four (24) inches below finished grade. Within the Chugach service area the minimum burial depth is thirty (30) inches.
- 507.27 The Utility requires remote service post load centers to be labeled with a code designating the type of load: MC for miscellaneous loads not coded here, LS - sewage lift stations, LU - streetlighting, PS - water pump stations, RR - Railroad and TS - traffic signalization. The lettering shall be cut vinyl decals (3-M Scotchcal 220), embossed metal or engraved laminated plastic with a $\frac{3}{4}$ - inch minimum letter height. The labeling requirement includes an ownership label (printed reflective decals are permitted with no letter height requirement other than legibility).

SECTION 500 - INSTALLATION GUIDELINES & SPECIFICATIONS

508 Commercial Hinged-Top Service Pedestal

- 508.1 All applicable requirements and specifications from other sections of this book apply to these installation guidelines and specifications.
- 508.2 The customer shall furnish and install a commercial service pedestal meeting the requirements of Section 604.
- 508.3 Self-contained meter sockets used in commercial service pedestal installations shall meet the general requirements of Section 307.
- 508.4 Commercial service pedestals used in the Utility's service area shall be the **hinged-top** design. Fixed-top design commercial service pedestals are prohibited from use on the Utility system.
- 508.5 Commercial service pedestals shall have meter sockets equipped with the safety socket feature and factory installed test-block bypass facilities.
- 508.6 The meter disconnect (circuit breaker) used in commercial service pedestal applications shall be clearly identified as the "main disconnect" and shall be easily distinguished from other circuit breakers present in the customer section.
- 508.7 Commercial service pedestal service installations shall meet the clearance and working space requirements of Section 303 and Section 521.
- 508.8 Commercial service pedestal service installations shall meet the applicable grounding and bonding requirements of Section 304. Where ground rods are used as part of the grounding electrode system, they shall be placed a minimum of thirty-six (36) inches from any Utility underground conductors, pad-mounted transformers, or poles.
- 508.9 The customer shall furnish and install a suitable concrete mounting base for the commercial service pedestal. The concrete mounting base shall be approved by the Utility.
- 508.10 **The preferred mounting height for commercial service pedestals is fifty (50) inches.** The maximum mounting height for commercial service pedestals is sixty-five (65) inches. The minimum mounting height for commercial service pedestals is forty-two (42) inches. Mounting height is measured from the centerline of the meter socket opening to the finished grade or standing surface immediately in front of the meter. Refer to Subsection 508.11.
- 508.11 The concrete base or pad on which a commercial service pedestal is mounted plays a critical role in meeting mounting height requirements. Mounting height **is measured** from the centerline of the meter socket opening to the finished grade or standing surface immediately in front of the meter. Mounting height **is not** measured from the top of the concrete base on which the commercial service pedestal is mounted. The height of the concrete mounting base **must be included** when determining the mounting height in a commercial service pedestal installation.
- 508.12 The customer shall furnish and install service riser conduits for the Utility's (line-side) service conductors meeting the general requirements of Section 520.
- 508.13 Service riser conduits for entry of the Utility's (line-side) service conductors into commercial service pedestals shall be placed within the commercial service pedestal's concrete mounting base such that the conduits come up under the utility service conductor termination section or compartment. Service riser conduits **shall not** be placed in a section or compartment other than the service termination section or compartment.

(Continued on page 76)

SECTION 500 - INSTALLATION GUIDELINES & SPECIFICATIONS

508 Commercial Hinged-Top Service Pedestal

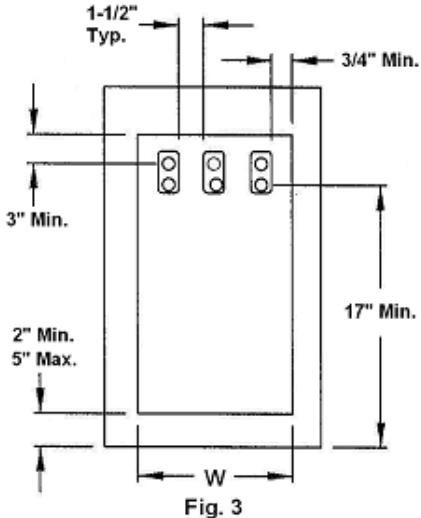
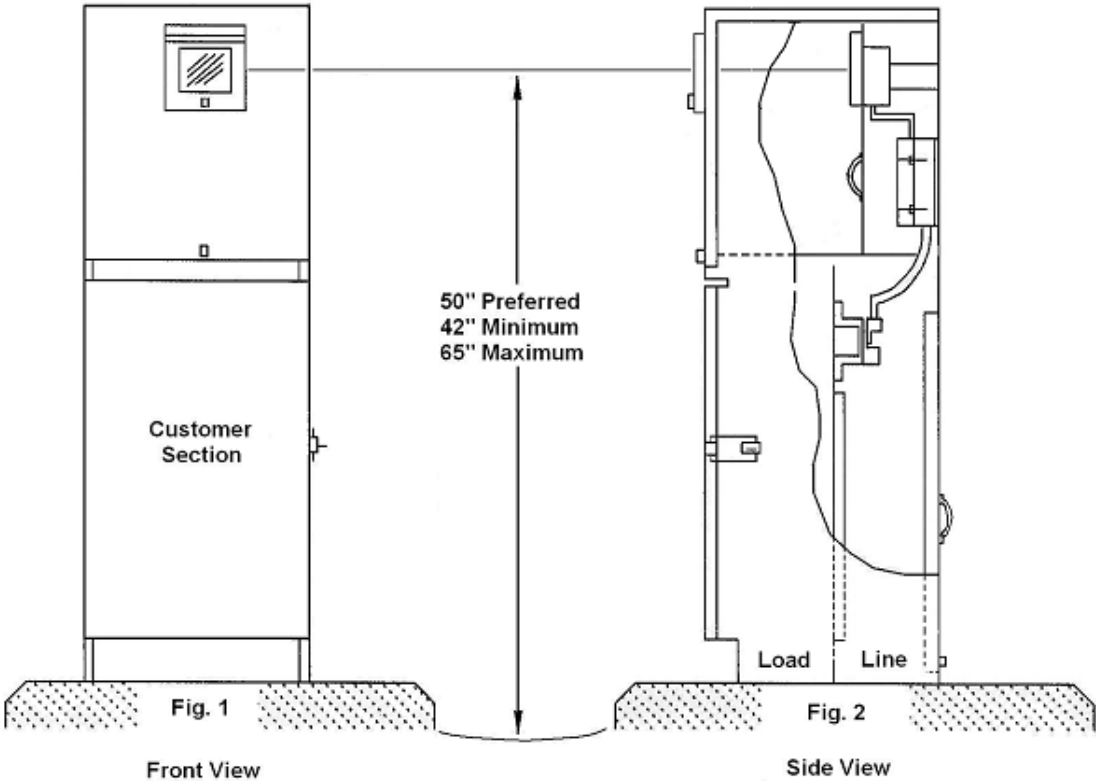

ALL DIMENSIONS SHOWN ARE IN INCHES

SECTION 500 - INSTALLATION GUIDELINES & SPECIFICATIONS

508 Commercial Hinged-Top Service Pedestal

- 508.14 Service riser conduits for entry of the Utility's (line-side) service conductors into a commercial service pedestal shall include 90-degree, 24-inch minimum radius conduit elbows (rigid metal conduit only) to transition from the horizontal part of the conduit run to the vertical part of the conduit run.
- 508.15 The horizontal section of each service riser conduit shall extend out from the termination section or compartment a minimum of twelve (12) inches and no more than forty-eight (48) inches from the outside edge of the concrete base on which the commercial service pedestal is mounted.
- 508.16 Except where otherwise specified in this book, the horizontal section of each service riser conduit shall be placed so that the top of the conduit is twenty-four (24) inches below finished grade thirty (30) inches within the Chugach service area). The twenty-four (24) inch depth is the standard burial depth. Within the Chugach service area the standard burial depth is thirty 30 inches.
- 508.17 Where commercial service pedestals are installed in a Municipality of Anchorage (MOA) road Right-Of-Way (ROW) or in a State of Alaska (SOA) road ROW, the top of the horizontal section of the service riser conduit may be placed up to a maximum of forty-eight (48) inches below finished grade where conflicts with other necessary underground facilities exist.
- 508.18 Where commercial service pedestals have the horizontal section of the service riser conduit placed below twenty-four (24) inches, the horizontal section shall transition from the non-standard depth to the standard 24-inch depth (30-inch within the Chugach service area) within forty-eight (48) inches of the concrete base on which the commercial service pedestal is placed.
- 508.19 The transition of the horizontal section of the service riser conduit from a non-standard depth to the standard depth of twenty-four (24) inches (30-inch within the Chugach service area) may be accomplished by means of conduit bending or by means of a combination of conduit fittings such as 22-1/2 degree and/or 45-degree conduit fittings.
- 508.20 Where commercial service pedestals are placed less than forty-eight (48) inches from the Utility's underground service facilities such as pad mount transformers or secondary service pedestals, the requirement to transition from the non-standard depth to the required depth of twenty-four (24) inches is waived. Within the Chugach service area commercial service pedestals are required to be located within 15-feet, but no closer than ten (10) feet from the power source. The commercial service pedestal location shall be approved by Chugach Engineering in advance of installation.
- 508.21 The Utility requires commercial service pedestals to be labeled with a code designating the type of load: MC for miscellaneous loads not coded here, LS - sewage lift stations, LU - streetlighting, PS - water pump stations, RR - Railroad and TS - traffic signalization. The lettering shall be cut vinyl decals (3-M Scotchcal 220), embossed metal or engraved laminated plastic with a 3/4 - inch minimum letter height. The labeling requirement includes an ownership label (printed reflective decals are permitted for ownership labels with no letter height requirement other than legibility).

SECTION 500 - INSTALLATION GUIDELINES & SPECIFICATIONS

RESERVED

SECTION 500 - INSTALLATION GUIDELINES & SPECIFICATIONS

509 Multiple Metering, Residential, 6-Meter Maximum

- 509.1 All applicable requirements and specifications from other sections of this book apply to these installation guidelines and specifications.
- 509.2 The customer shall furnish and install a combination terminating enclosure and multi-meter panel for residential services with two (2) to six (6) meter socket positions meeting the requirements of Section 606.
- 509.3 All multiple metering equipment shall be placed outdoors on the exterior of the building or structure in accordance with Section 302.
- 509.4 Residential multiple metering installations shall meet the general requirements of Section 308.
- 509.5 Residential multiple metering equipment having from two (2) to six (6) meter socket positions shall have a terminating pull section or compartment that meets the requirements of Section 606.
- 509.6 Residential multiple metering equipment rated 201 amps and above shall have service conductor termination facilities meeting the requirements of Section 627.
- 509.7 Residential multiple metering equipment shall meet the clearance requirements of Section 607.
- 509.8 Residential multiple metering equipment with six (6) or fewer meter socket positions **shall not** have a main service disconnect on the source side (line-side, ahead of the meter sockets). Installations with six (6) sockets or less shall follow the meter-switch-fuse sequence.
- 509.9 The maximum mounting height for multi-metering panels is seventy-five (75) inches. The minimum mounting height for multi-metering panels is thirty-three (33) inches. Mounting height is measured from the centerline of the meter socket opening to the finished grade or standing surface immediately in front of the meters. The 75-inch maximum height applies to the uppermost socket opening and the 33-inch minimum height applies to the lowermost socket opening of the multi-metering equipment. This multi-metering height requirement applies to both commercial and residential applications.
- 509.10 The meter sockets of a multi-family residential building serving “house power” or “common area” loads within the building or structure shall be considered as “residential” with respect to safety socket and test-block bypass requirements, as long as such sockets are included as part of the common enclosure or modular component of multiple metering equipment. In such cases, the requirement for the safety socket feature with test-block bypass does not apply.
- 509.11 Residential multiple metering installations shall meet the clearance and working space requirements of Section 521.
- 509.12 Residential multiple metering installations shall meet the socket labeling and identification requirements of Section 308. Meters will not be installed and the service will not be energized until identification and labeling of each meter socket position and corresponding identification and labeling of each respective space, unit, suite, or apartment is complete. The socket identification and labeling, and the corresponding identification and labeling shall not be considered as complete unless all labeling is permanent in nature.
- 509.13 Network service requires a factory installed 5th jaw or a factory supplied 5th jaw kit to be located in the nine (9) o'clock position for each meter socket.

(Continued on page 80)

SECTION 500 - INSTALLATION GUIDELINES & SPECIFICATIONS

509 Multiple Metering, Residential, 6-Meter Maximum

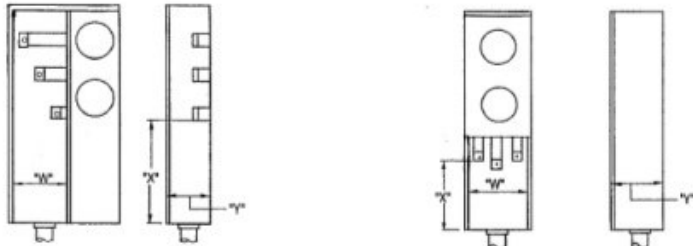

Typical Service Terminating Arrangements: 2-Meters (0-200 Amps)

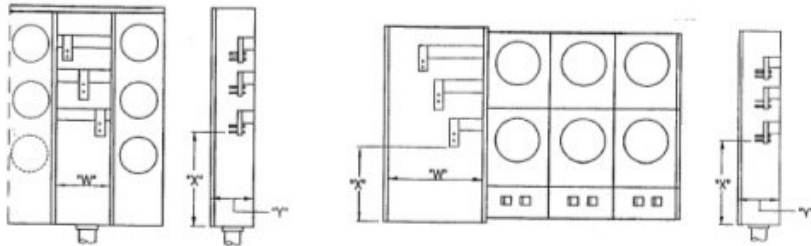

Typical Service Terminating Arrangements: 3-6 Meters (201-600 Amps)

SECTION 500 - INSTALLATION GUIDELINES & SPECIFICATIONS

509 Multiple Metering, Residential, 6-Meter Maximum

- 509.14 Meter sockets equipped with a 5th jaw for Network service but served from a single-phase, 3-wire, 120/240 volt source, must have the 5th jaw and its associated wiring removed from each meter socket.
- 509.15 The customer shall furnish and install service riser conduits for the Utility's (line-side) service conductors meeting the general requirements of Section 520.
- 509.16 Service riser conduits for all applications rated 201 amps and above shall be rigid metal conduit.
- 509.17 Service riser conduits shall be secured in place. Service riser conduits shall be anchored to the building or structure with a minimum of one (1) conduit strap or clamp (24-inch minimum clamp spacing).
- 509.18 Service riser conduits for entry of the Utility's (line-side) service conductors into terminating pull sections or compartments shall include ninety (90) degree, 24-inch minimum radius conduit elbows (rigid metal conduit only) to transition from the horizontal part of the conduit run to the vertical part of the conduit run.
- 509.19 The horizontal section of each service riser conduit shall extend out from the terminating pull section or compartment a minimum of twelve (12) inches and no more than forty-eight (48) inches from the pull section or compartment on which it is landed.
- 509.20 Except where otherwise specified in this book, the horizontal section of each service riser conduit shall be placed so that the top of the conduit is twenty-four (24) inches below finished grade. Within the Chugach service area the minimum burial depth is thirty (30) inches.

SECTION 500 - INSTALLATION GUIDELINES & SPECIFICATIONS

509 Multiple Metering, Residential, 6-Meter Maximum

SUGGESTED SERVICE EQUIPMENT CONFIGURATION FOR MULTI-UNIT RESIDENTIAL BUILDINGS WITH 6 METERS OR LESS, REQUIRING A SEPARATE SERVICE FOR FIRE SUPPRESSION EQUIPMENT.

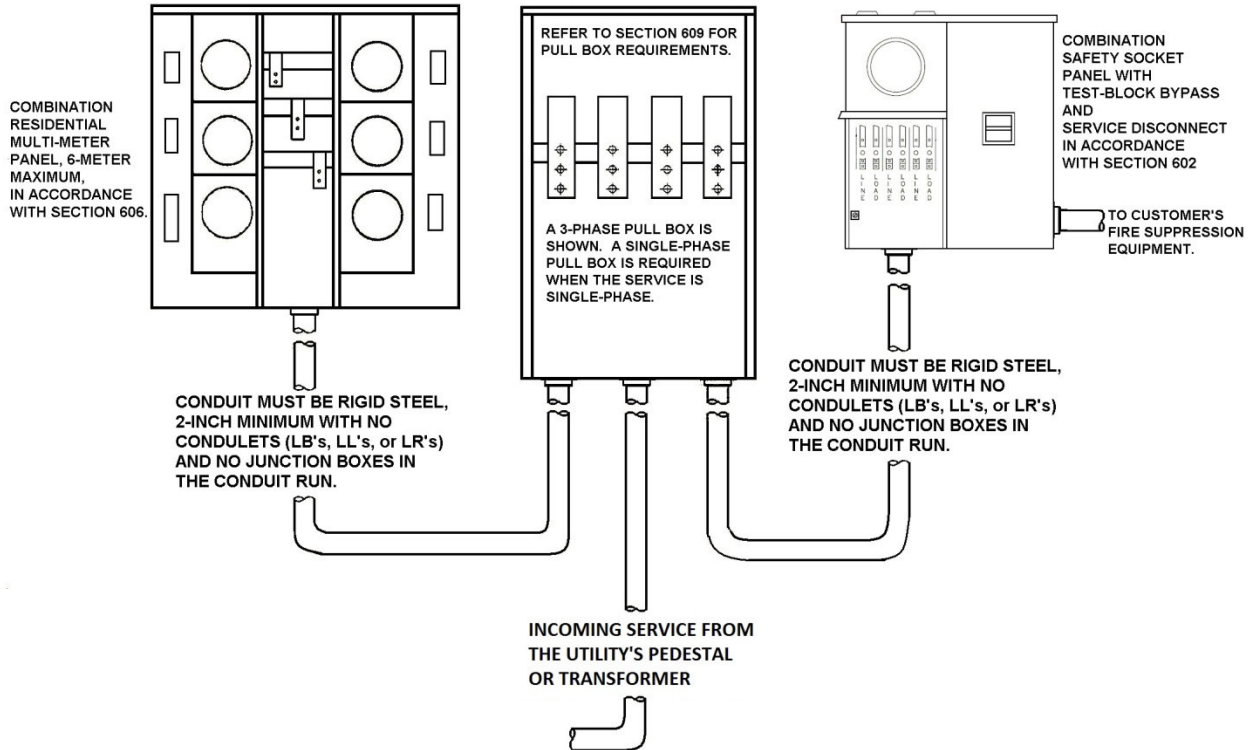

SECTION 500 - INSTALLATION GUIDELINES & SPECIFICATIONS

510-A Multiple Metering, Commercial, 6-Meter Maximum, Modular

- 510-A.1 All applicable requirements and specifications from other sections of this book apply to these installation guidelines and specifications.
- 510-A.2 The customer shall furnish and install a wall-mounted pull box with modular cross bus facilities and service conductor terminating facilities, and two (2) or more wall-mounted modular meter safety sockets with meter disconnects.
- 510-A.3 Wall-mounted multiple metering equipment, including wall-mounted pull boxes and wall-mounted modular meter safety sockets with meter disconnects shall be placed outdoors on the exterior of the building or structure in accordance with Section 302.
- 510-A.4 All parts of wall-mounted multiple metering installations shall meet the general requirements of Section 308.
- 510-A.5 The modular meter sockets shall meet the pertinent parts of Section 602 with respect to the safety socket feature, the test-block bypass facilities and the service disconnects, and shall meet the general requirements of Section 307.
- 510-A.6 The wall-mounted pull box with terminating facilities shall meet the requirements of Section 609.
- 510-A.7 The maximum ampere rating for wall-mounted pull boxes with terminating facilities used in the Utility's service area is 1,200 amps. Refer to Section 303 for service ampacity rating information. Within the Chugach service area the maximum single-phase service equipment rating is 800 amperes for certain applications. Chugach Engineering must evaluate all single-phase services above 800A, in advance of installation.
- 510-A.8 Multiple metering installations rated 201 amps and above shall have service conductor termination facilities meeting the requirements of Section 627.
- 510-A.9 Wall-mounted pull boxes and vertically arranged meter modules shall be designed by the manufacturer specifically for wall-mounted modular metering applications.
- 510-A.10 Multiple metering equipment used in commercial applications shall have no more than three (3) meter socket positions per vertical column or module.
- 510-A.11 Multiple metering equipment with six (6) or fewer meter socket positions **shall not** have a main service disconnect on the source side (line-side, ahead of the meter sockets). Installations with six (6) sockets or less shall follow the meter-switch-fuse sequence.
- 510-A.12 The maximum mounting height for multi-metering panels is seventy-five (75) inches. The minimum mounting height for multi-metering panels is thirty-three (33) inches. Mounting height is measured from the centerline of the meter socket opening to the finished grade or standing surface immediately in front of the meters. The 75-inch maximum height applies to the uppermost socket opening and the 33-inch minimum height applies to the lowermost socket opening of the multi-metering equipment. This multi-metering height requirement applies to both commercial and residential applications.
- 510-A.13 The preferred mounting height of a wall-mounted pull box with terminating facilities in most cases is determined by the type and style of metering equipment it serves, especially where the pull box is configured with cross bus facilities related to modular metering.

(Continued on page 84)

SECTION 500 - INSTALLATION GUIDELINES & SPECIFICATIONS

510-A Multiple Metering, Commercial, 6-Meter Maximum, Modular

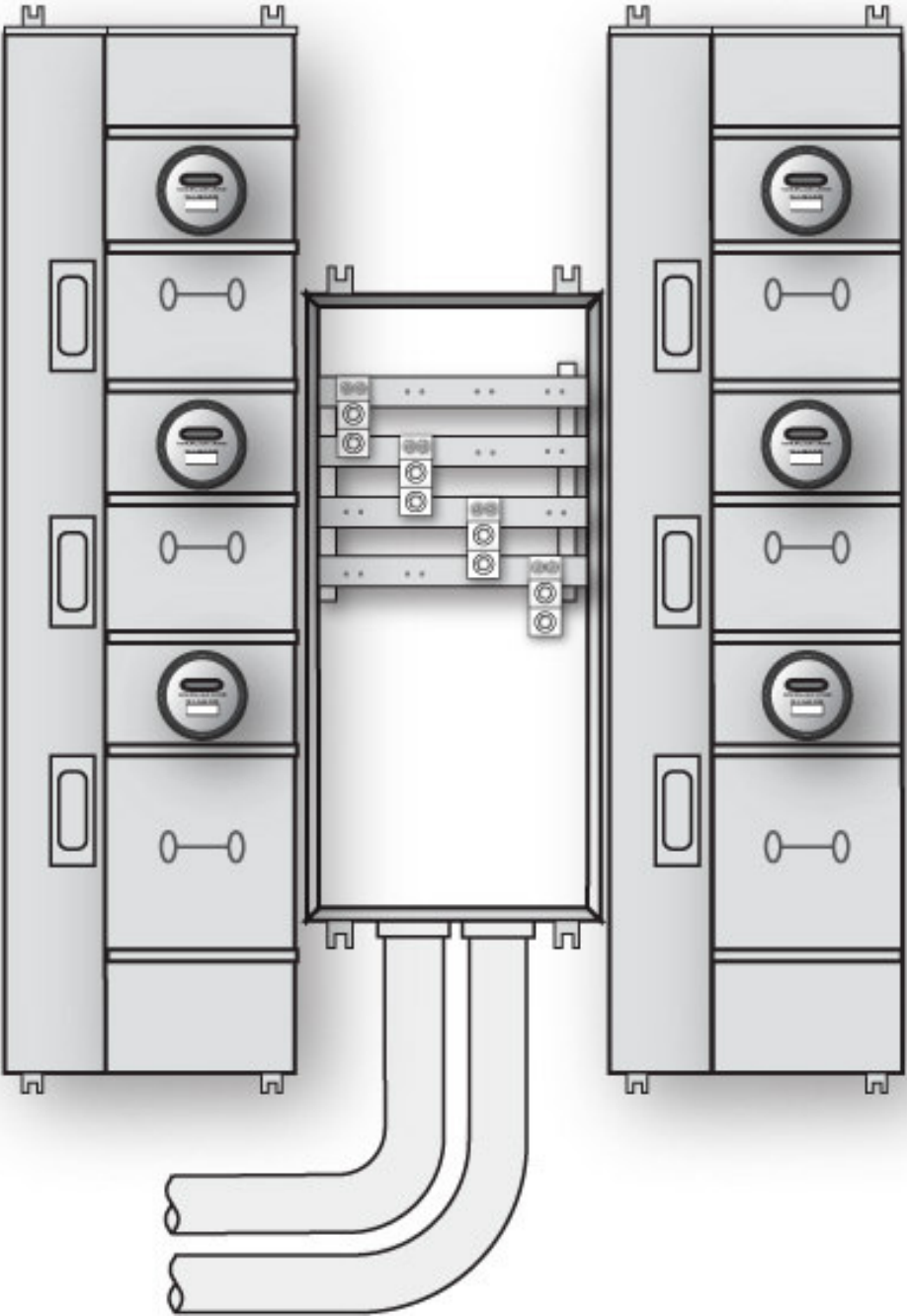

SECTION 500 - INSTALLATION GUIDELINES & SPECIFICATIONS

510-A Multiple Metering, Commercial, 6-Meter Maximum, Modular

- 510-A.14 The maximum mounting height for a wall-mounted pull box with terminating facilities is ninety (90) inches. Mounting height is measured from the top of the wall-mounted pull box to the finished grade or standing surface immediately in front of the wall-mounted pull box.
- 510-A.15 No wall-mounted pull box with terminating facilities shall be installed with the floor or bottom of the enclosure less than twelve (12) inches above the finished grade or standing surface immediately in front of the enclosure.
- 510-A.16 Installing wall-mounted modular multi-metering equipment with different capacity ratings (e.g. 100 amp rated and 200 amp rated) may result in the inability to meet both minimum and maximum mounting height requirements. When using wall-mounted modular multi-metering equipment, make sure multi-metering modules with different capacity ratings are capable of meeting mounting height requirements.
- 510-A.17 Wall-mounted modular multiple metering equipment shall meet the clearance and working space requirements of Section 521.
- 510-A.18 Bus spacer devices may be required to meet the meter side clearance requirements of Subsections 303.11 and 521.10.
- 510-A.19 Multiple metering installations shall meet the socket labeling and identification requirements of Section 308. Meters will not be installed and the service will not be energized until identification and labeling of each meter socket position and corresponding identification and labeling of each respective space, unit, suite, or apartment is complete. The socket identification and labeling, and the corresponding identification and labeling shall not be considered as complete unless all labeling is permanent in nature.
- 510-A.20 Network services require a factory installed 5th jaw or factory supplied 5th jaw kit to be located in the nine (9) o'clock position for each meter socket.
- 510-A.21 Meter sockets equipped with a 5th jaw for Network service but served from a single-phase, 3-wire, 120/240 volt source, must have the 5th jaw and its associated wiring removed from each meter socket.
- 510-A.22 The customer shall furnish and install service riser conduits for the Utility's (line-side) service conductors meeting the general requirements of Section 520.
- 510-A.23 Service riser conduits for all applications rated 201 amps and above shall be rigid metal conduit.
- 510-A.24 Service riser conduits shall be secured in place. Service riser conduits shall be anchored to the building or structure with a minimum of one (1) conduit strap or clamp (24-inch minimum clamp spacing).
- 510-A.25 Service riser conduits extending out from the floor or bottom of wall-mounted service termination compartments shall be placed so that the top of the conduit on the horizontal section is twenty-four (24) inches below finished grade. Within the Chugach service area the minimum burial depth is thirty (30) inches.
- 510-A.26 Except as otherwise specified, the horizontal section of the service riser conduits for the Utility's (line-side) service conductors shall extend out from the wall-mounted service termination compartment no more than forty-eight (48) inches.

SECTION 500 - INSTALLATION GUIDELINES & SPECIFICATIONS

RESERVED

SECTION 500 - INSTALLATION GUIDELINES & SPECIFICATIONS

510-B Multiple Metering, Commercial, 6-Meter Maximum, Top-Bussed

- 510-B.1 All applicable requirements and specifications from other sections of this book apply to these installation guidelines and specifications.
- 510-B.2 The customer shall furnish and install a wall-mounted pull box with terminating facilities, a bussed gutter for ganging multiple meter panels under a common feed, and from two (2) to six (6) combination safety socket panels with test-block bypass and service disconnects.
- 510-B.3 Wall-mounted multiple metering equipment; including wall-mounted pull boxes, bussed gutters, meter sockets, and meter disconnects shall be placed outdoors on the exterior of the building or structure in accordance with Section 302.
- 510-B.4 All parts of wall-mounted multiple metering installations shall meet the general requirements of Section 308.
- 510-B.5 The combination safety socket panels with test-block bypass and service disconnect shall meet the requirements of Sections 307 and 602.
- 510-B.6 The wall-mounted pull box with terminating facilities shall meet the requirements of Section 609.
- 510-B.7 The wall-mounted pull box shall have an ampere rating greater than or equal to the total combined ampere rating of all metering equipment served from that pull box in conformance with the service ampacity rating requirements of Section 303. Within the Chugach service area exceptions to this ampere rating requirement are available based on the engineer's, NEC based, service equipment rating.
- 510-B.8 Multiple metering installations rated 201 amps and above shall have service conductor termination facilities meeting the requirements of Section 627.
- 510-B.9 Multiple metering equipment with six (6) or fewer meter socket positions **shall not** have a main service disconnect on the source side (line-side, ahead of the meter sockets). Installations with six (6) sockets or less shall follow the meter-switch-fuse sequence.
- 510-B.10 Bussed gutters used for ganging individual meter panels under a common feed shall be designed by the bussed gutter manufacturer specifically for such use. The bussed gutter shall include pre-punched holes on the bottom surface of the gutter designed for the attachment of overhead-feed safety socket panels with test-block bypass facilities.
- 510-B.11 Bussed gutters used for ganging individual meter panels under a common feed are designed by the manufacturer to be used in conjunction with overhead-feed safety sockets with test-block bypass facilities. The overhead-feed safety sockets have hub openings that correspond to factory provided openings on the bottom side of the factory bussed gutter. Overhead-feed combination safety socket panel with test-block bypass and service disconnect features are required.
- 510-B.12 The bussed gutter shall be sealable or lockable and shall meet the requirements of Section 305.
- 510-B.13 The bussed gutter shall have an ampere rating equal to or greater than the total combined ampere rating of all meter panels served from that gutter.

(Continued on page 88)

SECTION 500 - INSTALLATION GUIDELINES & SPECIFICATIONS

510-B Multiple Metering, Commercial, 6-Meter Maximum, Top-Bussed

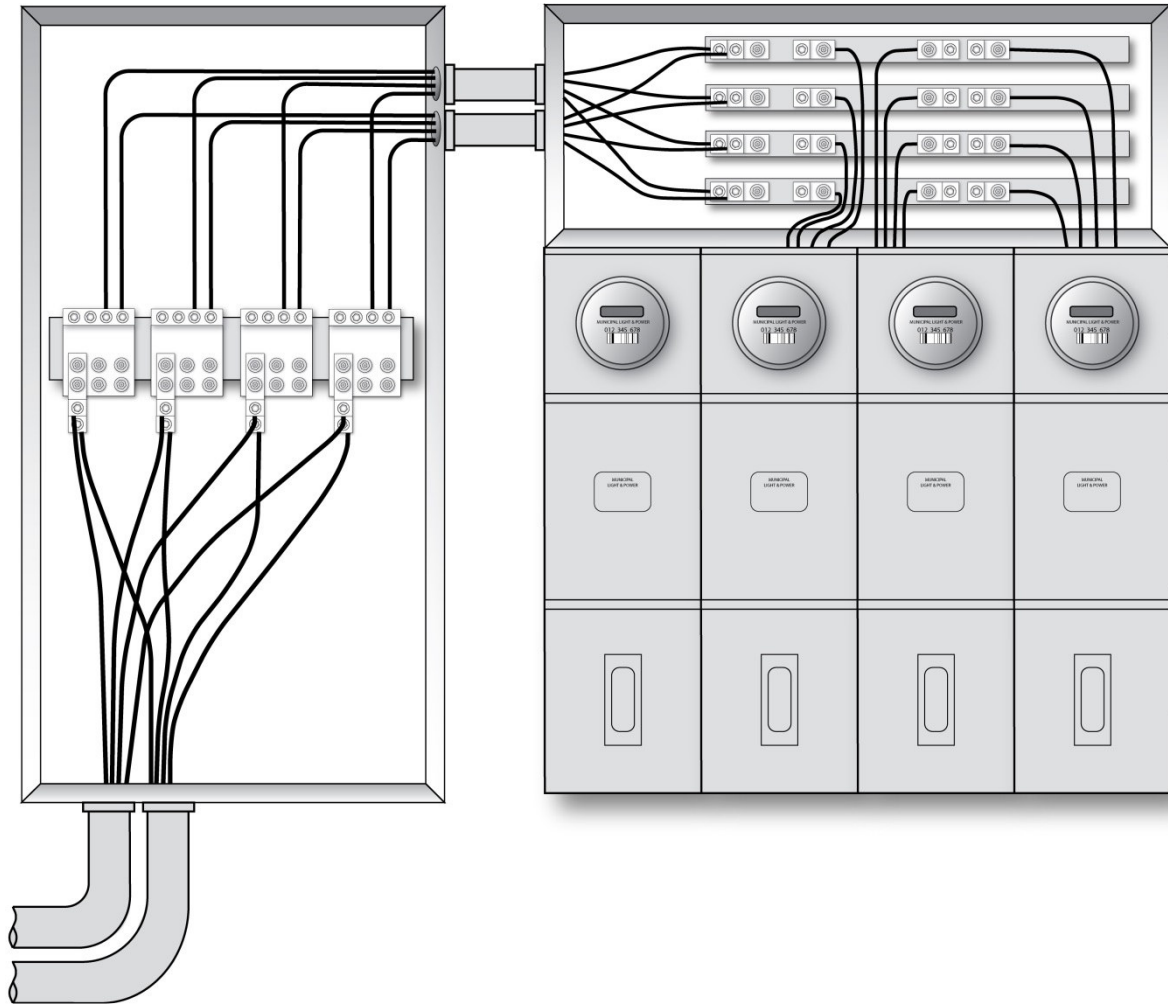

SECTION 500 - INSTALLATION GUIDELINES & SPECIFICATIONS

510-B Multiple Metering, Commercial, 6-Meter Maximum, Top-Bussed

- 510-B.14 The bussed gutter for ganging individual meter sockets under common feed shall only be installed **above** the meter panels which it serves.
- 510-B.15 The maximum mounting height for a bussed gutter used for ganging from two (2) to six (6) meter panels under a common feed is ninety (90) inches. Mounting height is measured from the top of the bussed gutter to the finished grade or standing surface immediately in front of the bussed gutter.
- 510-B.16 **The preferred mounting height for wall-mounted multiple metering using overhead feed combination safety socket panels with test-block bypass and service disconnects is sixty-five (65) inches.** The maximum mounting height for wall-mounted multiple metering using overhead feed combination safety socket panels with test-block bypass and service disconnects is sixty-eight (68) inches. The minimum mounting height for wall-mounted multiple metering using overhead feed combination safety socket panels with test-block bypass and service disconnects fifty-eight (58) inches. Mounting height is measured from the centerline of the meter socket opening to the finished grade or standing surface immediately in front of the meter.
- 510-B.17 Wall-mounted modular multiple metering equipment shall meet the clearance and working space requirements of Section 521.
- 510-B.18 Bus spacer devices may be required to meet the meter side clearance requirements of Subsections 303.11 and 521.10.
- 510-B.19 Multiple metering installations shall meet the socket labeling and identification requirements of Section 308. Meters will not be installed and the service will not be energized until identification and labeling of each meter socket position and corresponding identification and labeling of each respective space, unit, suite, or apartment is complete. The socket identification and labeling, and the corresponding identification and labeling shall not be considered as complete unless all labeling is permanent in nature.
- 510-B.20 Network services require a factory installed 5th jaw or factory supplied 5th jaw kit to be located in the nine (9) o'clock position for each meter socket.
- 510-B.21 Meter sockets equipped with a 5th jaw for Network service but served from a single-phase, 3-wire, 120/240 volt source, must have the 5th jaw and its associated wiring removed from each meter socket.
- 510-B.22 The customer shall furnish and install service riser conduits for the Utility's (line-side) service conductors meeting the general requirements of Section 520.
- 510-B.23 Service riser conduits for all applications rated 201 amps and above shall be rigid metal conduit.
- 510-B.24 Service riser conduits shall be secured in place. Service riser conduits shall be anchored to the building or structure with a minimum of one (1) conduit strap or clamp (24-inch minimum clamp spacing).

SECTION 500 - INSTALLATION GUIDELINES & SPECIFICATIONS

510-B Multiple Metering, Commercial, 6-Meter Maximum, Top-Bussed

510-B.25 Service riser conduits extending out from the floor or bottom of wall-mounted service termination compartments shall be placed so that the top of the conduit on the horizontal section is twenty-four (24) inches below finished grade. Within the Chugach service area the minimum burial depth is thirty (30) inches.

510-B.26 Except as otherwise specified in this book, the horizontal section of the service riser conduits for the Utility's (line-side) service conductors shall extend out from the wall-mounted service termination compartment no more than forty-eight (48) inches.

SECTION 500 - INSTALLATION GUIDELINES & SPECIFICATIONS

511 Multiple Metering, Self-Contained and CT Rated

- 511.1 All applicable requirements and specifications from other sections of this book apply to these installation guidelines and specifications.
- 511.2 The customer shall furnish and install a wall-mounted pull box with terminating facilities, the necessary number of CT rated meter sockets, CT cabinets, CT mounting bases, meter disconnects, self-contained meter sockets, a bussed gutter as needed, and all related service entrance equipment.
- 511.3 Wall-mounted multiple metering equipment, including wall-mounted pull boxes, meter sockets, CT cabinets, and meter disconnects shall be placed outdoors on the exterior of the building or structure in accordance with Section 302.
- 511.4 The CT rated part of wall-mounted multiple metering shall meet the general requirements of Section 309 and the installation guidelines and specifications of Section 515.
- 511.5 The self-contained part of wall-mounted multiple metering shall meet the general requirements of Section 307, and the installation guidelines and specifications of Sections 506 or 510-B.
- 511.6 All parts of wall-mounted multiple metering shall meet the general requirements of Section 308.
- 511.7 The customer shall furnish and install a wall-mounted pull box meeting the requirements of Section 609.
- 511.8 The wall-mounted pull box shall have an ampere rating greater than or equal to the total combined ampere rating of all metering equipment served from that pull box in conformance with the service ampacity rating requirements of Section 303. Within the Chugach service area exceptions to this ampere rating requirement are available based on the engineer's, NEC based, service equipment rating.
- 511.9 The total combined ampere rating of all metering equipment served shall not exceed 1,200 amps. Services with multiple metering and load requirements above 1,200 amps shall use switchboard service section type equipment for termination of the Utility's service conductors.
- 511.10 The Utility shall bring one set of service conductors to the wall-mounted pull box. The customer shall furnish and install conductors from the load-side position of the pull box terminating facilities to the line side of all respective CT mounting bases and to the line side of all self-contained meter sockets.
- 511.11 Multiple metering installations rated 201 amps and above shall have service conductor termination facilities meeting the requirements of Section 627.
- 511.12 No wall-mounted pull box with terminating facilities shall be installed with the floor or bottom of the enclosure less than twelve (12) inches above the finished grade or standing surface immediately in front of the enclosure.
- 511.13 Service conductors installed by the customer from the wall-mounted pull box to the respective CT cabinets and self-contained meter sockets are un-metered service conductors and shall be run in sealable compartments or unbroken conduits only. Un-metered service conductors and metered load conductors shall not occupy the same conduit, raceway, or wiring gutter.

(Continued on page 92)

SECTION 500 - INSTALLATION GUIDELINES & SPECIFICATIONS

511 Multiple Metering, Self-Contained and CT Rated

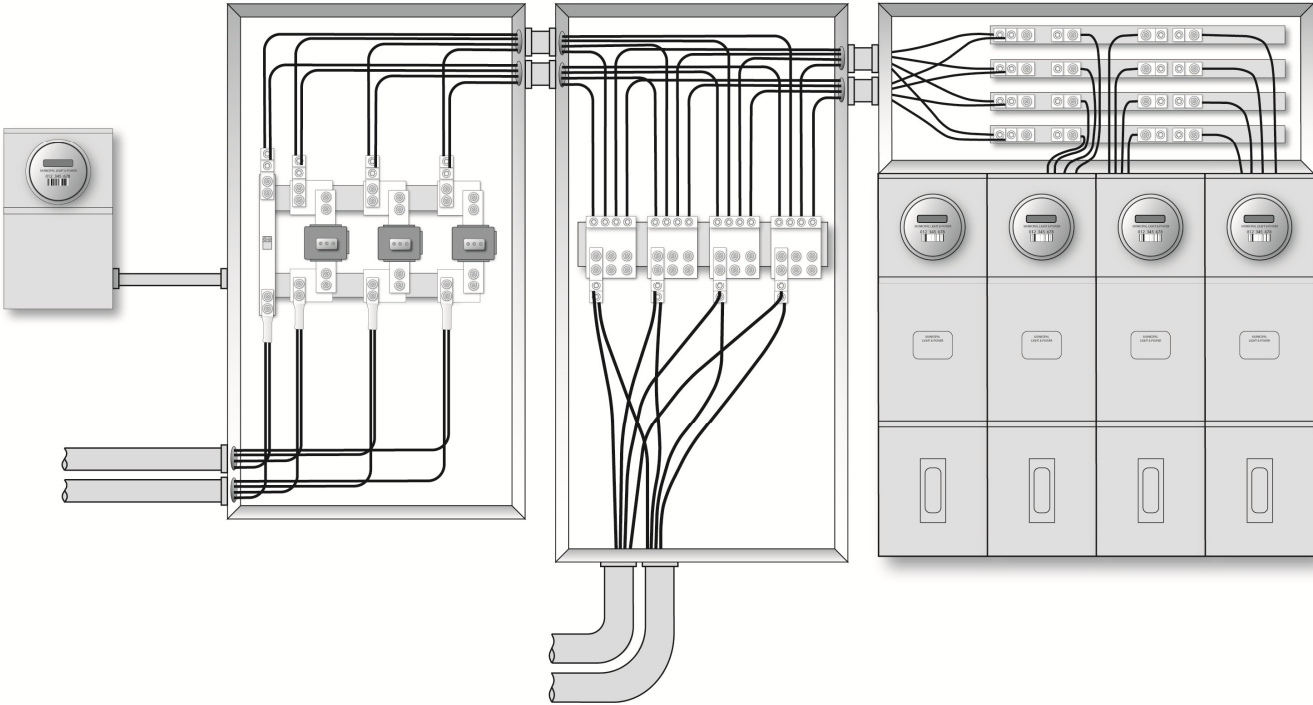

SECTION 500 - INSTALLATION GUIDELINES & SPECIFICATIONS

511 Multiple Metering, Self-Contained and CT Rated

- 511.14 No more than six (6) metered circuits shall be permitted and each metered circuit shall have only one (1) meter disconnect device. For installations requiring more than six (6) meters, switchboard service section style equipment shall be required.
- 511.15 Multiple metering equipment with six (6) or fewer meter socket positions **shall not** have a main service disconnect on the source side (line-side, ahead of the meter sockets). Installations with six (6) sockets or less shall follow the meter-switch-fuse sequence.
- 511.16 Self-contained meter sockets used in commercial, industrial, or non-residential applications shall meet the requirements of Section 602.
- 511.17 Multiple metering installations shall meet the socket labeling and identification requirements of Section 308. Meters will not be installed and the service will not be energized until identification and labeling of each meter socket position and corresponding identification and labeling of each respective space, unit, suite, or apartment is complete. The socket identification and labeling, and the corresponding identification and labeling shall not be considered as complete unless all labeling is permanent in nature.
- 511.18 Network services require a factory installed 5th jaw or factory supplied 5th jaw kit to be installed and located in the nine (9) o'clock position for each meter socket.
- 511.19 Meter sockets equipped with a 5th jaw for Network service but served from a single-phase, 3-wire, 120/240 volt source, must have the 5th jaw and its associated wiring removed from each meter socket.
- 511.20 The customer shall furnish and install service riser conduits for the Utility's (line-side) service conductors meeting the general requirements of Section 520.
- 511.21 Service riser conduits for all applications rated 201 amps and above shall be rigid metal conduit.
- 511.22 Service riser conduits shall be secured in place. Service riser conduits shall be anchored to the building or structure with a minimum of one (1) conduit strap or clamp (24-inch minimum clamp spacing).
- 511.23 Service riser conduits extending out from the floor or bottom of wall-mounted service termination compartments shall be placed so that the top of the conduit on the horizontal section is twenty-four (24) inches below finished grade. Within the Chugach service area the minimum burial depth is thirty (30) inches.
- 511.24 Except as otherwise specified in this book, the horizontal section of the service riser conduits for the Utility's (line-side) service conductors shall extend out from the wall-mounted service termination compartment no more than forty-eight (48) inches.

SECTION 500 - INSTALLATION GUIDELINES & SPECIFICATIONS

RESERVED

SECTION 500 - INSTALLATION GUIDELINES & SPECIFICATIONS

512 Multiple Metering, Wall-Mounted Style, 7-Meter Minimum

- 512.1 All applicable requirements and specifications from other sections of this book apply to these installation guidelines and specifications.
- 512.2 The customer shall furnish and install a wall-mounted service termination section, a wall-mounted main service disconnect, and as many wall-mounted multiple metering modules or sections as needed.
- 512.3 Wall-mounted multiple metering equipment, including service termination sections, metering sections, and main service disconnects shall be placed outdoors on the exterior of the building or structure in accordance with Section 302.
- 512.4 Wall-mounted multiple metering installations shall meet the general requirements of Section 308.
- 512.5 Wall-mounted modular multiple metering equipment used in residential applications shall meet the clearance requirements of Section 607.
- 512.6 Multiple metering equipment used in commercial, industrial, or non-residential applications shall have self-contained meter sockets equipped with the safety socket feature and test-block bypass facilities. The applicable parts of Sections 602 and 603 shall apply.
- 512.7 Multiple metering equipment used in residential applications qualifying under ML&P Rate Schedule 11 (and the Chugach Tariff for Residential service within the Chugach service area) is exempt from the safety socket and test-block bypass requirement.
- 512.8 The meter sockets of a multi-family residential building serving “house power” or “common area” loads shall be considered as “residential” with respect to safety socket and test-block bypass requirements, as long as such sockets are included as part of the common enclosure or modular component of multiple metering equipment. In such cases, the requirement for the safety socket feature with test-block bypass does not apply.
- 512.9 Multiple metering equipment used in mixed use applications (part commercial and part residential) shall have self-contained meter sockets equipped with the safety socket feature and test-block bypass facilities. The applicable parts of Sections 602 and 603 shall apply. The safety socket and test-block bypass exemption for residential sockets **does not** apply in mixed use applications.
- 512.10 Multiple metering equipment with seven (7) or more meter socket positions shall have a main service disconnect installed on the source side (line-side, ahead of the meter sockets). This is the only circumstance where a customer disconnect switch is allowed ahead of the Utility’s meters.
- 512.11 Multiple metering installations with seven (7) or more meter socket positions shall have a main service disconnect meeting the requirements of Section 306.
- 512.12 Main service disconnects installed on the source side (line-side, ahead of the meter sockets) of a multiple metering installation, whether residential application or commercial application, shall have factory designed and installed sealing and/or locking provisions to seal or lock all areas of the enclosure except for access for fuse replacement or switch operation.

(Continued on page 96)

SECTION 500 - INSTALLATION GUIDELINES & SPECIFICATIONS

512 Multiple Metering, Wall-Mounted Style, 7-Meter Minimum

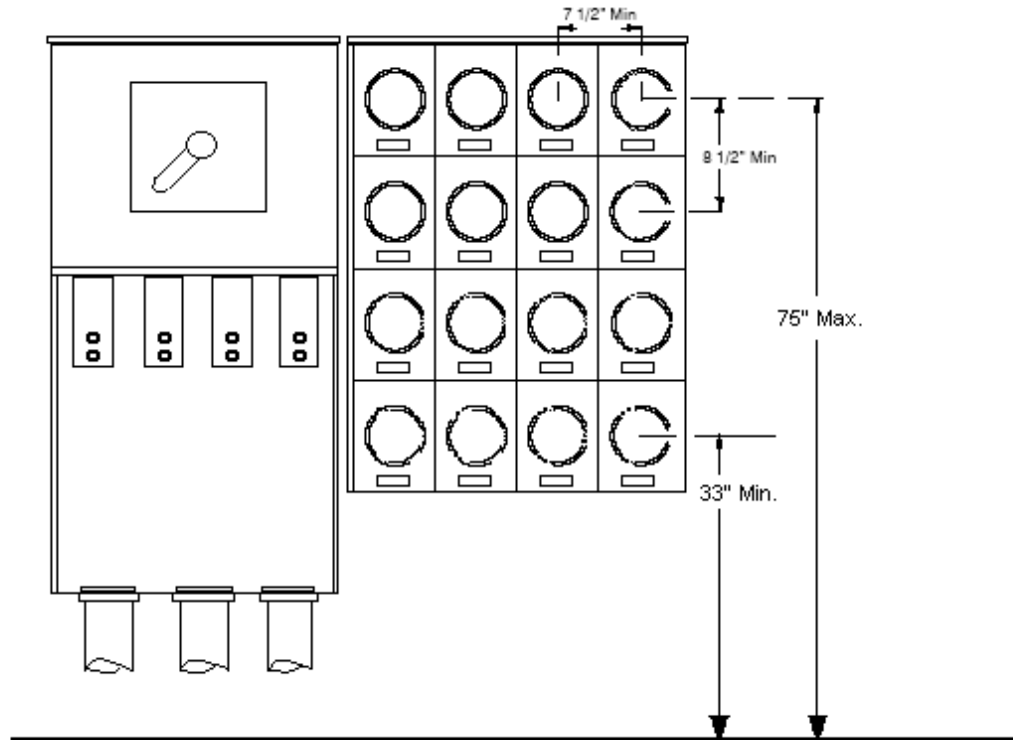

Meter Socket Modules

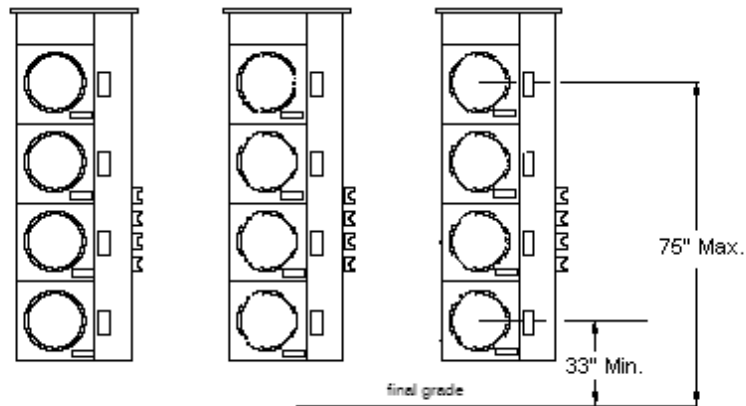

TYPICAL COMBINATION DISCONNECT DEVICE AND TERMINATING ENCLOSURE SHOWN WITH
RESIDENTIAL STYLE MODULAR MULTI-METERING EQUIPMENT
ALL DIMENSIONS SHOWN ARE IN INCHES

SECTION 500 - INSTALLATION GUIDELINES & SPECIFICATIONS

512 Multiple Metering, Wall-Mounted Style, 7-Meter Minimum

- 512.13 Combination disconnect device and terminating enclosures used in multiple metering applications shall meet the requirements of Section 608.
- 512.14 The maximum ampere rating for combination disconnect device and service terminating enclosures used in the Utility's service area shall be 1,200 amps. Refer to Section 303 for service ampacity rating details. Within the Chugach service area the maximum single-phase service equipment rating is 800 amperes for certain applications. Chugach Engineering must evaluate all single-phase services above 800A, in advance of installation.
- 512.15 Multiple metering equipment used in commercial applications shall have no more than three (3) meter socket positions per vertical column or module.
- 512.16 Multiple metering equipment used in residential applications shall have no more than four (4) meter socket positions per vertical column or module.
- 512.17 The maximum mounting height for multi-metering panels is seventy-five (75) inches. The minimum mounting height for multi-metering panels is thirty-three (33) inches. Mounting height is measured from the centerline of the meter socket opening to the finished grade or standing surface immediately in front of the meters. The 75-inch maximum height applies to the uppermost socket opening and the 33-inch minimum height applies to the lowermost socket opening of the multi-metering equipment. This multi-metering height requirement applies to both commercial and residential applications.
- 512.18 Installing wall-mounted modular multi-metering equipment with different capacity ratings (e.g. 100 amp rated and 200 amp rated) may result in the inability to meet both minimum and maximum mounting height requirements. When using wall-mounted modular multi-metering equipment, make sure multi-metering modules with different capacity ratings are capable of meeting mounting height requirements.
- 512.19 Wall-mounted modular multiple metering equipment shall meet the clearance and working space requirements of Section 521.
- 512.20 Bus spacer devices may be required to meet the meter side clearance requirements of Subsections 303.11 and 521.10.
- 512.21 Multiple metering installations shall meet the socket labeling and identification requirements of Section 308. Meters will not be installed and the service will not be energized until identification and labeling of each meter socket position and corresponding identification and labeling of each respective space, unit, suite, or apartment is complete. The socket identification and labeling, and the corresponding identification and labeling shall not be considered as complete unless all labeling is permanent in nature.
- 512.22 Network services require a factory installed 5th jaw or factory supplied 5th jaw kit to be installed and located in the nine (9) o'clock position for each meter socket.
- 512.23 Meter sockets equipped with a 5th jaw for Network service but served from a single-phase, 3-wire, 120/240 volt source, must have the 5th jaw and its associated wiring removed from each meter socket.
- 512.24 The customer shall furnish and install service riser conduits for the Utility's (line-side) service conductors meeting the general requirements of Section 520.

SECTION 500 - INSTALLATION GUIDELINES & SPECIFICATIONS

512 Multiple Metering, Wall-Mounted Style, 7-Meter Minimum

- 512.25 Service riser conduits for all applications rated 201 amps and above shall be rigid metal conduit.
- 512.26 Service riser conduits shall be secured in place. Service riser conduits shall be anchored to the building or structure with a minimum of one (1) conduit strap or clamp (24-inch minimum spacing).
- 512.27 Service riser conduits extending out from the floor or bottom of wall-mounted service termination compartments shall be placed so that the top of the conduit on the horizontal section of the elbow/sweep is twenty-four (24) inches below finished grade. Within the Chugach service area the minimum burial depth is thirty (30) inches.
- 512.28 Except as otherwise specified in this book, the horizontal section of the service riser conduits of the elbow/sweep for the Utility's (line-side) service conductors shall extend out from the wall-mounted service termination compartment no more than forty-eight (48) inches.

SECTION 500 - INSTALLATION GUIDELINES & SPECIFICATIONS

513 Multiple Metering, Switchboard Style, 7-Meter Minimum

- 513.1 All applicable requirements and specifications from other sections of this book apply to these installation guidelines and specifications.
- 513.2 The customer shall furnish and install a switchboard service section with terminating facilities, a switchboard service section with a main service disconnect where required, and as many multiple metering switchboard sections as needed.
- 513.3 Switchboard service sections and all associated service entrance equipment, including termination sections, metering sections, and main service disconnects shall be placed outdoors on the exterior of the building or structure in accordance with Section 302.
- 513.4 Switchboard service sections and all related components shall meet the general requirements of Section 310.
- 513.5 Switchboard service sections configured with multiple meter sockets shall meet the general requirements of Section 308.
- 513.6 Switchboard service sections used in multiple metering applications shall have an underground service termination compartment meeting the requirements of Section 625 or 626.
- 513.7 Switchboard service sections used in multiple metering applications shall have underground service termination facilities meeting the requirements of Section 627.
- 513.8 The switchboard service section shall have an outdoor enclosure meeting the requirements of Section 619.
- 513.9 Switchboard service sections with seven (7) or more meter socket positions shall have a main service disconnect installed on the source side (line-side, ahead of the meter sockets). This is the only circumstance where a customer disconnect switch is allowed ahead of the Utility's meters.
- 513.10 The main service disconnect of a switchboard service section installation shall meet the requirements of Section 306.
- 513.11 Main service disconnects on the source side (line-side, ahead of the meter sockets) of a multiple metering installation shall have factory designed and installed sealing and/or locking provisions to seal or lock all areas of the enclosure except for access for fuse replacement or switch operation.
- 513.12 Self-contained meter sockets installed in switchboards shall be equipped with safety socket and test-block bypass facilities and shall meet the requirements of Section 603.
- 513.13 Switchboard service section style equipment with self-contained meter sockets shall have no more than three (3) meter socket positions per vertical column or section.
- 513.14 The maximum mounting height for multi-metering panels is seventy-five (75) inches. The minimum mounting height for multi-metering panels is thirty-three (33) inches. Mounting height is measured from the centerline of the meter socket opening to the finished grade or standing surface immediately in front of the meters. The 75-inch maximum height applies to the uppermost socket opening and the 33-inch minimum height applies to the lowermost socket opening of the multi-metering equipment. This multi-metering height requirement applies to both commercial and residential applications.

(Continued on page 100)

SECTION 500 - INSTALLATION GUIDELINES & SPECIFICATIONS

513 Multiple Metering, Switchboard Style, 7-Meter Minimum

Non-Residential Switch Board Metering (Direct-connect, Floor Mounted)

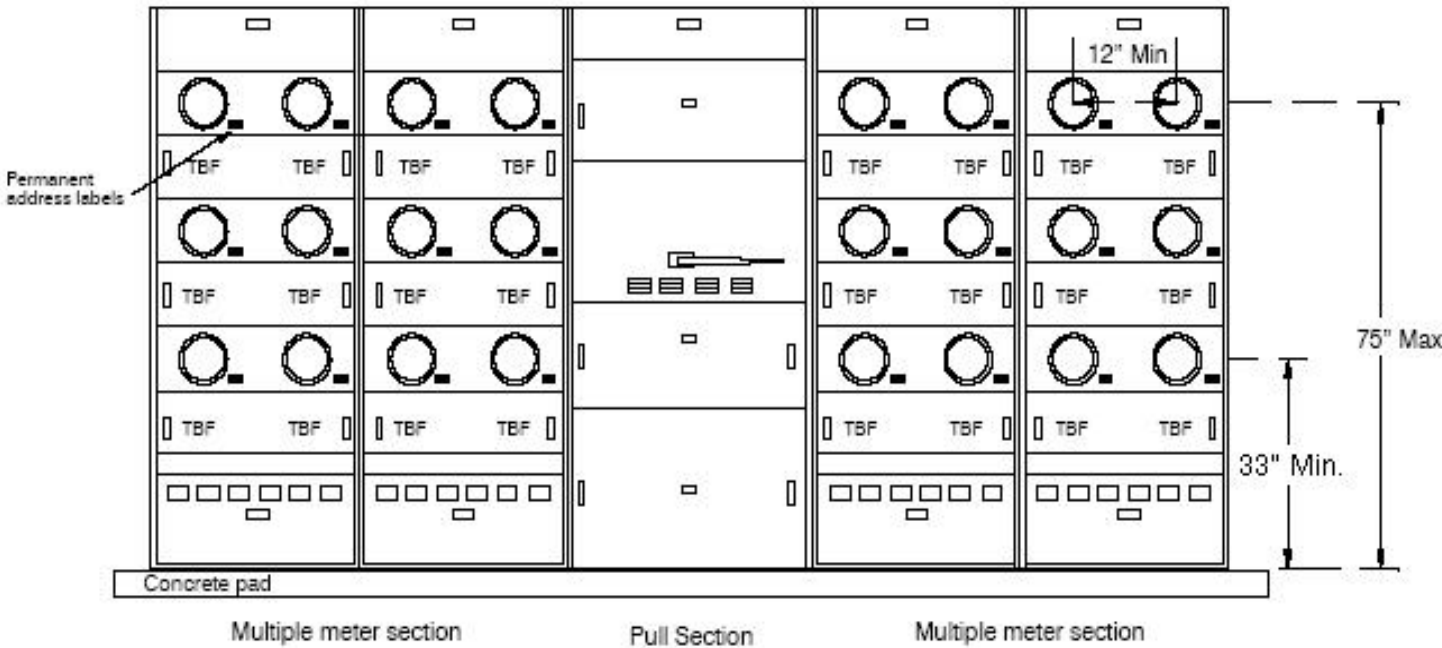

ALL DIMENSIONS SHOWN ARE IN INCHES

SECTION 500 - INSTALLATION GUIDELINES & SPECIFICATIONS

513 Multiple Metering, Switchboard Style, 7-Meter Minimum

- 513.15 Network services require a factory installed 5th jaw or factory supplied 5th jaw kit to be located in the 9 o'clock position for each meter socket.
- 513.16 Multiple metering installations shall meet the socket labeling and identification requirements of Section 308. Meters will not be installed and the service will not be energized until identification and labeling of each meter socket position and corresponding identification and labeling of each respective space, unit, suite, or apartment is complete. The socket identification and labeling, and the corresponding identification and labeling shall not be considered as complete unless all labeling is permanent in nature.
- 513.17 Switchboard service sections shall be placed on a concrete pad suitably configured for delivery of electric service from the Utility. All specifications related to barriers and separation of unmetered conductors or bus (utility line-side) and metered conductors or bus (customer load-side) of switchboard service sections shall extend to the concrete pad; unmetered conductors or bus (utility line-side) and metered conductors or bus (customer load-side) shall not occupy the same space, conduit, raceway, or compartment.
- 513.18 The height of the concrete pad on which the switchboard metering section is placed must be considered when determining meter socket height.
- 513.19 The customer shall furnish and install service riser conduits for the Utility's (line-side) service conductors meeting the general requirements of Section 520.
- 513.20 Service riser conduits for entry of the Utility's (line-side) service conductors into a switchboard service termination section shall have ninety (90)-degree, 24-inch minimum radius conduit elbows (rigid metal conduit only) and each conduit shall extend out from the outside edge of the concrete pad a minimum of twelve (12) inches and a maximum of forty-eight (48) inches.
- 513.21 Service riser conduits extending out from switchboard service sections shall be placed so that the top of the conduit on the horizontal section is twenty-four (24) inches below finished grade. Within the Chugach service area the minimum burial depth is thirty (30) inches.
- 513.22 Service riser conduits for entry of the Utility's (line-side) service conductors into switchboard service sections shall have the conduits placed within the switchboard's concrete mounting pad such that the conduits come up under the appropriate service termination section. Service riser conduits of switchboard service sections shall be placed under no compartment other than the service termination section or compartment. All switchboard service section specifications related to barriers and separation of unmetered conductors or bus (utility line-side) and metered conductors or bus (customer load-side) include the concrete mounting pad and the service riser conduits. This may necessitate stacking of conduits.

SECTION 500 - INSTALLATION GUIDELINES & SPECIFICATIONS

RESERVED

SECTION 500 - INSTALLATION GUIDELINES & SPECIFICATIONS

514 Single-Phase CT Service, Wall-Mounted, 201 Amps to 800 Amps

- 514.1 All applicable requirements and specifications from other sections of this book apply to these installation guidelines and specifications.
- 514.2 CT service installations rated from 201 amps to 800 amps, using wall-mounted equipment, shall meet the general requirements of Section 309.
- 514.3 The CT enclosure, CT mounting base, CT rated meter socket, rigid metal conduit and related fittings between the CT compartment and the meter socket shall be furnished and installed by the customer.
- 514.4 CT rated meter sockets, CT cabinets, and all associated service entrance equipment, including meter disconnects shall be placed outdoors on the exterior of the building or structure in accordance with Section 302.
- 514.5 The customer shall furnish and install a wall-mounted 6-terminal CT rated meter socket meeting the requirements of Section 605 for each CT rated metering point.
- 514.6 The customer shall furnish and install a wall-mounted CT cabinet meeting the requirements of Section 614 for each CT rated metering point.
- 514.7 The customer shall furnish and install a CT mounting base meeting the requirements of Section 610 or 611 for each CT rated metering point.
- 514.8 The customer shall furnish and install an approved meter disconnect meeting the requirements of Section 306 for each CT rated metering point.
- 514.9 The Utility shall furnish the CTs; the customer shall install the CTs (within the Chugach service area Chugach will install the CTs). The Utility shall furnish and install the test switch and CT wiring.
- 514.10 The customer shall install the ML&P supplied CTs with the white dot (polarity mark) or H1 side facing the source (ML&P) side.
- 514.11 CT rated meter socket enclosures shall be bonded to their respective CT cabinets by means of a No. 6 AWG stranded copper conductor, insulated with a green jacket. The No. 6 AWG stranded copper conductor shall be installed in accordance with all applicable articles of the latest revision of the NEC.
- 514.12 The conduit connecting the meter socket enclosure to the CT cabinet shall be a direct run with no access points such as junction boxes or condulets with access covers. Total conduit length shall be twenty-five (25) feet or less. The conduit shall be rigid metal conduit and shall have a minimum diameter of one (1) inch. Conduit bending shall be limited to a maximum of 270 degrees total.
- 514.13 The conduit connecting the meter socket to the CT cabinet shall land on one of the factory supplied knockouts below the test switch perch area only.

(Continued on page 104)

SECTION 500 - INSTALLATION GUIDELINES & SPECIFICATIONS

514 Single-Phase CT Service, Wall-Mounted, 201 Amps to 800 Amps

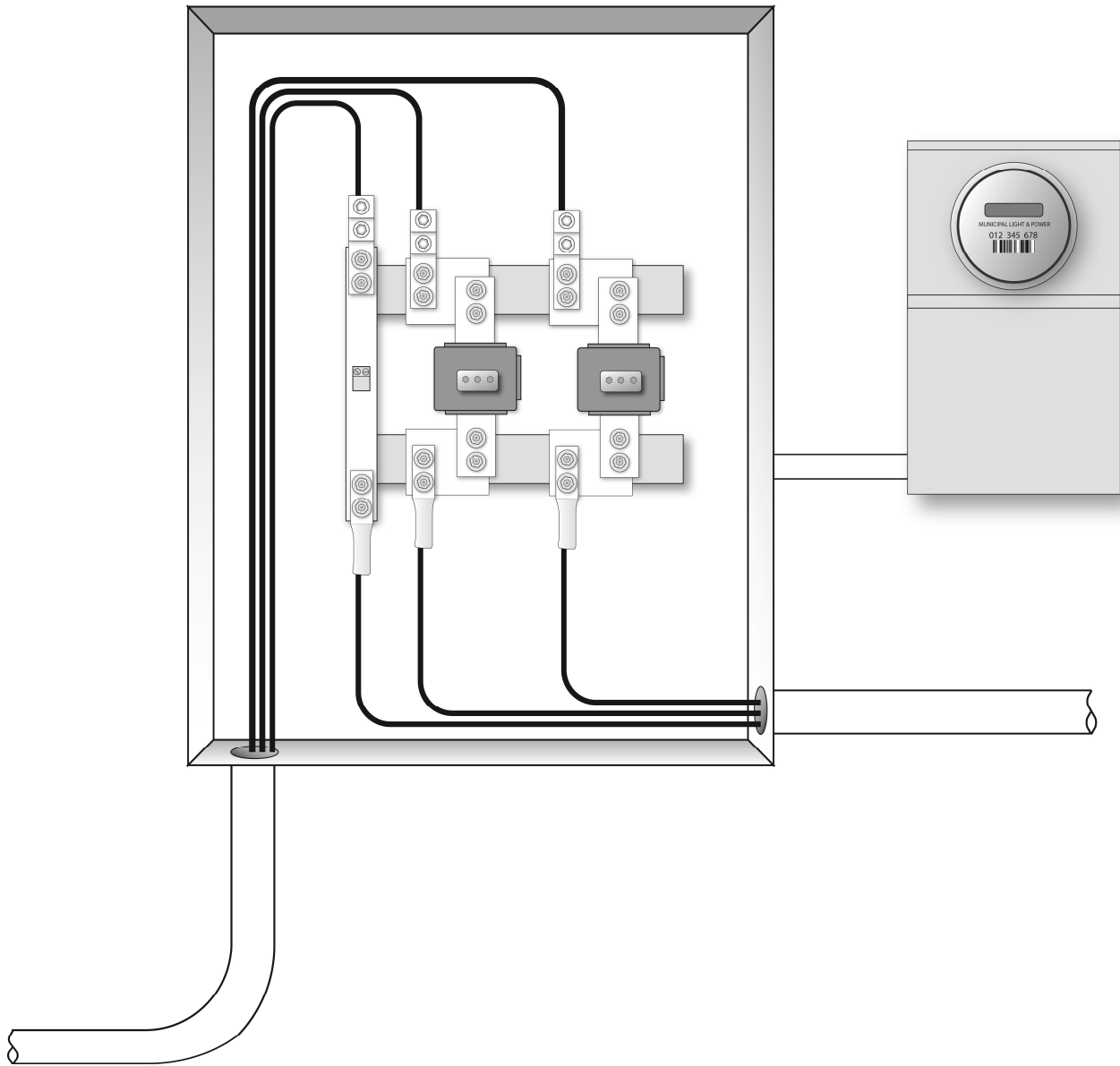

SECTION 500 - INSTALLATION GUIDELINES & SPECIFICATIONS

514 Single-Phase CT Service, Wall-Mounted, 201 Amps to 800 Amps

- 514.14 The meter socket shall be installed so that there is a minimum of ten (10) inches of side clearance. The minimum 10-inch side clearance requirement extends to both sides of the meter.
- 514.15 **The preferred mounting height for surface-mounted CT rated meter sockets is sixty-five (65) inches.** The maximum mounting height for surface-mounted CT rated meter sockets is seventy-two (72) inches. The minimum mounting height for surface-mounted CT rated meter sockets is sixty (60) inches. Mounting height is measured from the centerline of the meter socket opening to the finished grade or standing surface immediately in front of the meter.
- 514.16 **The preferred mounting height for wall-mounted CT cabinets on services rated up to 800 amps is seventy (70) inches.** The maximum mounting height for wall-mounted CT cabinets on services rated up to 800 amps is eighty-four (84) inches. The minimum mounting height for wall-mounted CT cabinets on services rated up to 800 amps is sixty-four (64) inches. Mounting height is measured from the top of the CT cabinet to the finished grade or standing surface immediately in front of the CT cabinet.
- 514.17 No wall-mounted CT cabinet shall be installed with the floor or bottom of the enclosure less than sixteen (16) inches above the finished grade or standing surface immediately in front of the cabinet.
- 514.18 **Cabinet Dimensions, Single-Phase, 201 to 400 Amps:** CT cabinets for single-phase services 201 to 400 amps shall have minimum dimensions of thirty-six (36) inches in height, thirty (30) inches in width, and eleven (11) inches in depth.
- 514.19 **Cabinet Dimensions, Single-Phase, 401 to 800 Amps:** CT cabinets for single-phase services 401 to 800 amps shall have minimum dimensions of thirty-six (36) inches in height, thirty-six (36) inches in width, and eleven (11) inches in depth.
- 514.20 The customer's (load-side) conductors **shall not** pass over the top of, in front of, or in any way restrict access to the Utility's (line-side) conductors or CTs. Depending on circumstances, a larger CT cabinet may be necessary to meet this requirement.
- 514.21 Placement of customer load-side conduits is a critical part of meeting the requirement of Subsection 514.20.
- 514.22 No connections shall be made in the CT cabinet to supply any other meter or service. CT cabinets **shall not** be used as a junction point to serve other metered circuits.
- 514.23 Hinged CT cabinet doors **shall be** properly aligned and adjusted for ease of operation. Doors that require pounding, hammering, and/or prying to remove and/or re-install are **not** acceptable. The Utility will not energize CT rated services with wall-mounted CT cabinets until it has been demonstrated that all hinged CT cabinet doors operate in an appropriate manner.
- 514.24 The customer shall furnish and install service riser conduits for the Utility's (line-side) service conductors meeting the general requirements of Section 520.
- 514.25 Service riser conduits for all applications rated 201 amps and above shall be rigid metal conduit.

SECTION 500 - INSTALLATION GUIDELINES & SPECIFICATIONS

514 Single-Phase CT Service, Wall-Mounted, 201 Amps to 800 Amps

- 514.26 Placement of service riser conduits for the Utility's (line-side) service conductors is critical in order to maintain proper wire bending radius and in order to comply with Subsection 514.20. The line-side service riser conduits must be grouped together and placed to either the left hand side or the right hand side of the CT cabinet, depending on the arrangement of other service equipment. The service riser conduits **shall not** be placed in the center of the CT cabinet.
- 514.27 Service riser conduits shall be secured in place. Service riser conduits **shall be** anchored to the building or structure with a minimum of one (1) conduit strap or clamp (24-inch minimum clamp spacing).
- 514.28 Service riser conduits extending out from the floor or bottom of wall-mounted CT cabinets shall be placed so that the top of the conduit on the horizontal section is twenty-four (24) inches below finished grade. Within the Chugach service area the minimum burial depth is thirty (30) inches.
- 514.29 Except as otherwise specified in this book, the horizontal section of the service riser conduits for the Utility's (line-side) service conductors shall extend out from the CT cabinet no more than forty-eight (48) inches.

SECTION 500 - INSTALLATION GUIDELINES & SPECIFICATIONS

515 Three-Phase CT Service, Wall-Mounted, 201 Amps to 800 Amps

- 515.1 All applicable requirements and specifications from other sections of this book apply to these installation guidelines and specifications.
- 515.2 CT service installations rated from 201 amps to 800 amps, using wall-mounted equipment, shall meet the general requirements of Section 309.
- 515.3 The CT enclosure, CT mounting base, CT rated meter socket, rigid metal conduit and related fittings between the CT compartment and the meter socket shall be furnished and installed by the customer.
- 515.4 CT rated meter sockets, CT cabinets, and all associated service entrance equipment, including meter disconnects shall be placed outdoors on the exterior of the building or structure in accordance with Section 302.
- 515.5 The customer shall furnish and install a wall-mounted 13-terminal CT rated meter socket meeting the requirements of Section 605 for each CT rated metering point.
- 515.6 The customer shall furnish and install a wall-mounted CT cabinet meeting the requirements of Section 614 for each CT rated metering point.
- 515.7 The customer shall furnish and install a CT mounting base meeting the requirements of Section 612 or 613 for each CT rated metering point.
- 515.8 The customer shall furnish and install an approved meter disconnect meeting the requirements of Section 306 for each CT rated metering point.
- 515.9 The Utility shall furnish the CTs; the customer shall install the CTs (within the Chugach service area Chugach will install the CTs). The Utility shall furnish and install the test switch and CT wiring.
- 515.10 The customer shall install the ML&P supplied CTs with the white dot (polarity mark) or H1 side facing the source (ML&P) side.
- 515.11 CT rated meter socket enclosures shall be bonded to their respective CT cabinets by means of a No. 6 AWG stranded copper conductor, insulated with a green jacket. The No. 6 AWG stranded copper conductor shall be installed in accordance with all applicable articles of the latest revision of the NEC.
- 515.12 The conduit connecting the meter socket enclosure to the CT cabinet shall be a direct run with no access points such as junction boxes or condulets with access covers. The total conduit length shall be twenty-five (25) feet or less. The conduit shall be rigid metal conduit and shall have a minimum diameter of one (1) inch. Conduit bending shall be limited to a maximum of 270 degrees total.
- 515.13 The conduit connecting the meter socket to the CT cabinet shall land on one of the factory supplied knockouts below the test switch perch area only.
- 515.14 The meter socket shall be installed so that there is a minimum of ten (10) inches of side clearance. The minimum ten (10)-inch side clearance requirement extends to both sides of the meter.

(Continued on page 108)

SECTION 500 - INSTALLATION GUIDELINES & SPECIFICATIONS

515 Three-Phase CT Service, Wall-Mounted, 201 Amps to 800 Amps

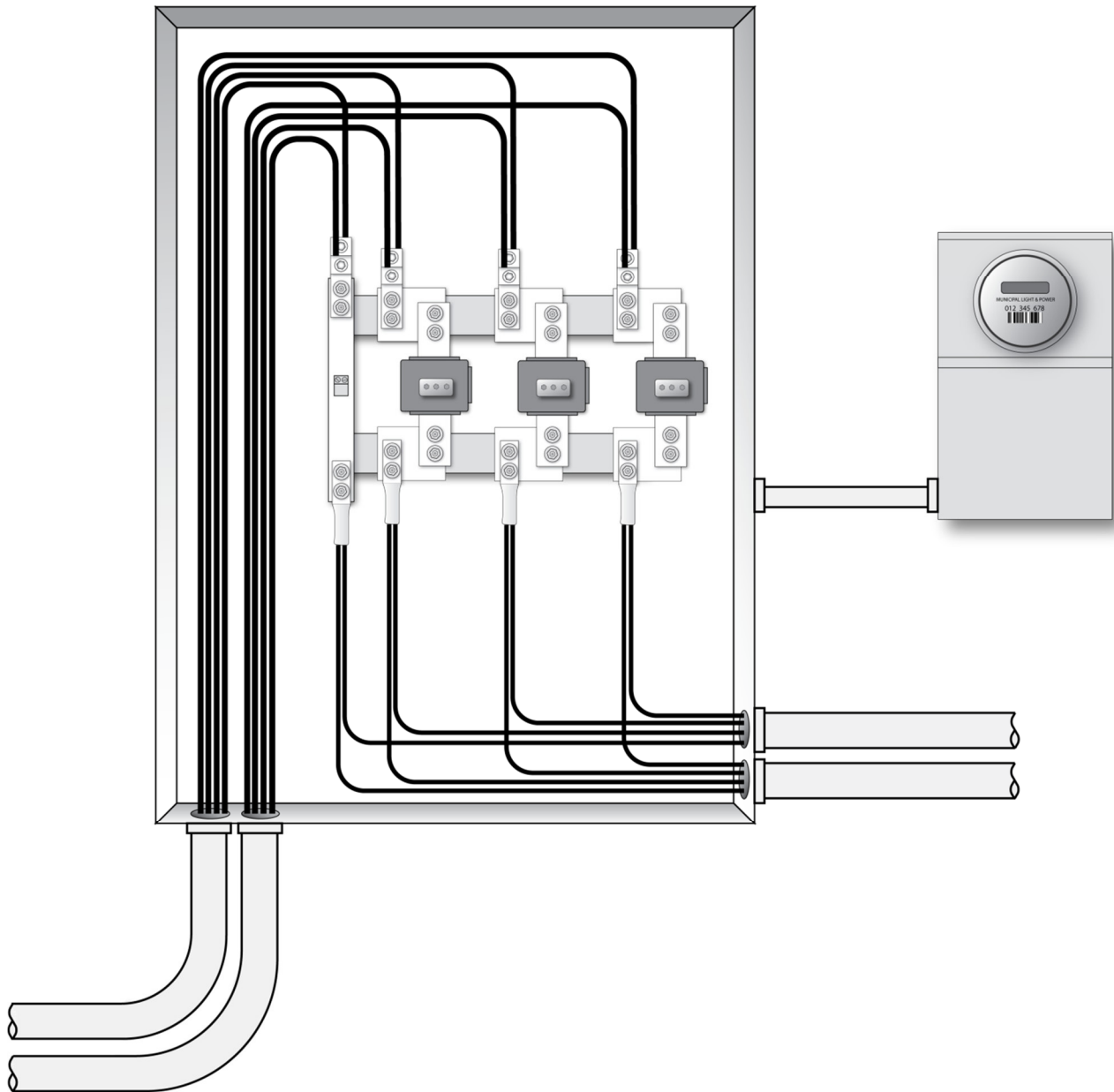

SECTION 500 - INSTALLATION GUIDELINES & SPECIFICATIONS

515 Three-Phase CT Service, Wall-Mounted, 201 Amps to 800 Amps

- 515.15 **The preferred mounting height for surface-mounted CT rated meter sockets is sixty-five (65) inches.** The maximum mounting height for surface-mounted CT rated meter sockets is seventy-two (72) inches. The minimum mounting height for surface-mounted CT rated meter sockets is sixty (60) inches. Mounting height is measured from the centerline of the meter socket opening to the finished grade or standing surface immediately in front of the meter.
- 515.16 **The preferred mounting height for wall-mounted CT cabinets on services rated up to 800 amps is seventy (70) inches.** The maximum mounting height for wall-mounted CT cabinets on services rated up to 800 amps is eighty-four (84) inches. The minimum mounting height for wall-mounted CT cabinets on services rated up to 800 amps is sixty-four (64) inches. Mounting height is measured from the top of the CT cabinet to the finished grade or standing surface immediately in front of the CT cabinet.
- 515.17 No wall-mounted CT cabinet shall be installed with the floor or bottom of the enclosure less than sixteen (16) inches above the finished grade or standing surface immediately in front of the cabinet.
- 515.18 **Cabinet Dimensions, Three-Phase, 201 to 600 Amps:** CT cabinets for three-phase services 201 to 600 amps shall have minimum dimensions of forty-eight (48) inches in height, thirty-six (36) inches in width, and eleven (11) inches in depth.
- 515.19 **Cabinet Dimensions, Three-Phase, 601 to 800 Amps:** CT cabinets for three-phase services 601 to 800 amps shall have minimum dimensions of forty-eight (48) inches in height, forty-eight (48) inches in width, and fourteen (14) inches in depth.
- 515.20 **Cabinet Dimension Exception, Three-Phase, 601 to 800 Amps:** The Utility may accept a CT cabinet with minimum dimensions of forty-eight (48) inches in height, thirty-six (36) inches in width, and eleven (11) inches in depth for services 601 amps to 800 amps where the customer can demonstrate unusual circumstances that would preclude the use of a standard forty-eight (48)-inch wide CT cabinet. Contact ML&P's Technical Services superintendent (within the Chugach service area contact the Engineering Division) for written approval prior to installation of a CT cabinet of non-standard width.
- 515.21 On three-phase CT rated services where circumstances require both the conduits for the customer's (load-side) conductors and the conduits for the Utility's (line-side) conductors to land on the bottom or floor of the cabinet, the minimum cabinet dimensions shall be forty-eight (48) inches in height, forty-eight (48) inches in width, and fourteen (14) inches in depth.
- 515.22 The customer's (load-side) conductors **shall not** pass over the top of, in front of, or in any way restrict access to the Utility's (line-side) conductors or CTs. Depending on circumstances, a larger CT cabinet may be necessary to meet this requirement.
- 515.23 Placement of the customer's (load-side) conduits is a critical part of meeting the requirement of Subsection 515.22.
- 515.24 No connections shall be made in the CT cabinet to supply any other meter or service. CT cabinets **shall not** be used as a junction point to serve other metered circuits.
- 515.25 Hinged CT cabinet doors **shall be** properly aligned and adjusted for ease of operation. Doors that require pounding, hammering, and/or prying to remove and/or re-install are **not** acceptable. The Utility will not energize CT rated services with wall-mounted CT cabinets until it has been demonstrated that all hinged CT cabinet doors operate in an appropriate manner.

SECTION 500 - INSTALLATION GUIDELINES & SPECIFICATIONS

515 Three-Phase CT Service, Wall-Mounted, 201 Amps to 800 Amps

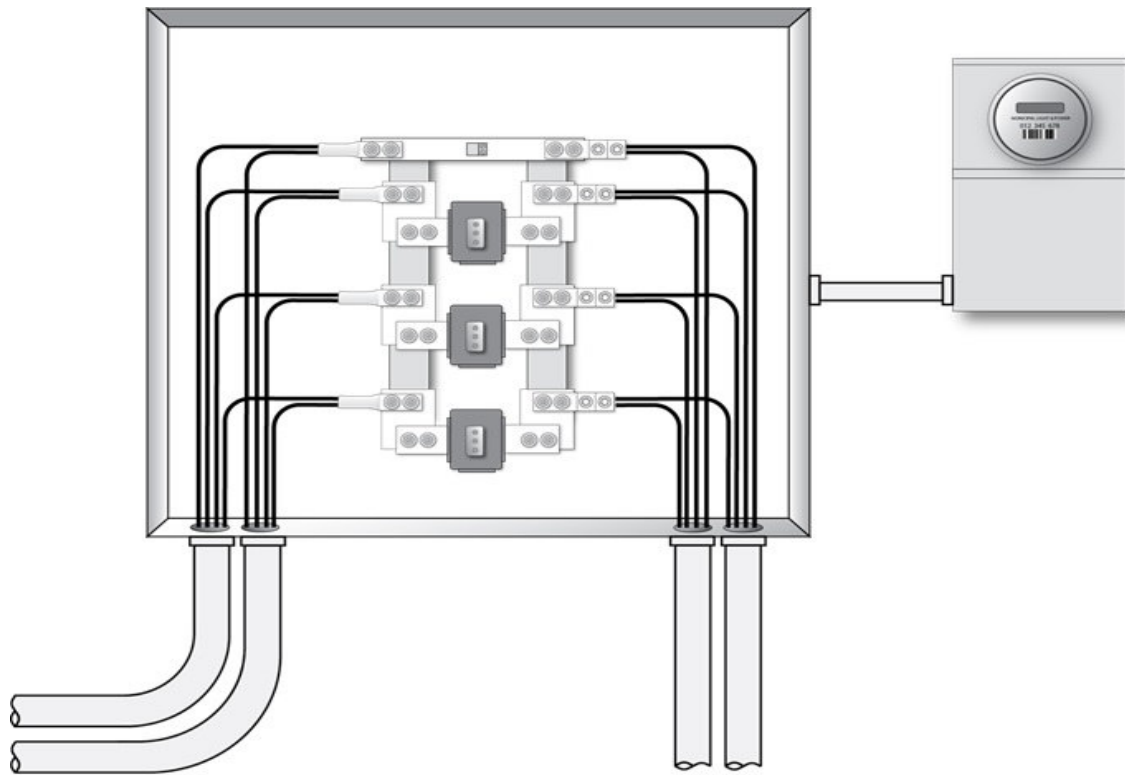

515.26 The customer shall furnish and install service riser conduits for the Utility's (line-side) service conductors meeting the general requirements of Section 520.

515.27 Service riser conduits for all applications rated 201 amps and above shall be rigid metal conduit.

515.28 Placement of service riser conduits for the Utility's (line-side) service conductors is critical in order to maintain proper wire bending radius and in order to comply with Subsection 515.22. The line-side service riser conduits must be grouped together and placed either to the left hand side or the right hand side of the CT cabinet, depending on the arrangement of other service equipment. The service riser conduits **shall not** be placed in the center of the CT cabinet.

515.29 Service riser conduits shall be secured in place. Service riser conduits **shall be** anchored to the building or structure with a minimum of one (1) conduit strap or clamp (24-inch minimum clamp spacing).

515.30 Service riser conduits extending out from the floor or bottom of wall-mounted CT cabinets shall be placed so that the top of the conduit on the horizontal section is twenty-four (24) inches below finished grade. Within the Chugach service area the minimum burial depth is thirty (30) inches.

515.31 Except as otherwise specified, the horizontal section of the service riser conduits for the Utility's (line-side) service conductors shall extend out from the CT cabinet no more than forty-eight (48) inches.

SECTION 500 - INSTALLATION GUIDELINES & SPECIFICATIONS

516 Three-Phase CT Service, Wall-Mounted, 801 Amps to 2,500 Amps

- 516.1 All applicable requirements and specifications from other sections of this book apply to these installation guidelines and specifications.
- 516.2 CT service installations rated from 801 amps to 2,500 amps, using wall-mounted equipment, shall meet the general requirements of Section 309.
- 516.3 The CT enclosure, CT mounting base or rack, CT rated meter socket, rigid metal conduit and related fittings between the CT compartment and the meter socket shall be furnished and installed by the customer.
- 516.4 CT rated meter sockets, CT cabinets, and all associated service entrance equipment, including meter disconnects shall be placed outdoors on the exterior of the building or structure in accordance with Section 302.
- 516.5 The customer shall furnish and install a wall-mounted 13-terminal CT rated meter socket meeting the requirements of Section 605 for each CT rated metering point.
- 516.6 The customer shall furnish and install a wall-mounted CT cabinet meeting the requirements of Section 615 for each CT rated metering point.
- 516.7 The customer shall furnish and install an approved meter disconnect meeting the requirements of Section 306 for each CT rated metering point.
- 516.8 The Utility will furnish the CTs; the customer shall install the CTs (within the Chugach service area Chugach will install the CTs). The Utility will furnish and install the test switch and CT wiring.
- 516.9 The customer shall install the ML&P supplied CTs with the white dot (polarity mark) or H1 side facing the source (ML&P) side.
- 516.10 CT rated meter socket enclosures shall be bonded to their respective CT cabinets by means of a No. 6 AWG stranded copper conductor, insulated with a green jacket. The No. 6 AWG stranded copper conductor shall be installed in accordance with all applicable articles of the latest revision of the NEC.
- 516.11 The conduit connecting the meter socket enclosure to the CT cabinet shall be a direct run with no access points such as junction boxes or condulets with access covers. The total conduit length shall be twenty-five (25) feet or less. The conduit shall be rigid metal conduit and shall have a minimum inside diameter of one (1) inch. Conduit bending shall be limited to a maximum of 270 degrees total.
- 516.12 The conduit connecting the meter socket to the CT cabinet shall land on one of the factory supplied knockouts below the test switch perch area only.
- 516.13 The meter socket shall be installed so that there is a minimum of ten (10) inches of side clearance. The minimum ten (10)-inch side clearance requirement extends to both sides of the meter.

(Continued on page 112)

SECTION 500 - INSTALLATION GUIDELINES & SPECIFICATIONS

516 Three-Phase CT Service, Wall-Mounted, 801 Amps to 2,500 Amps

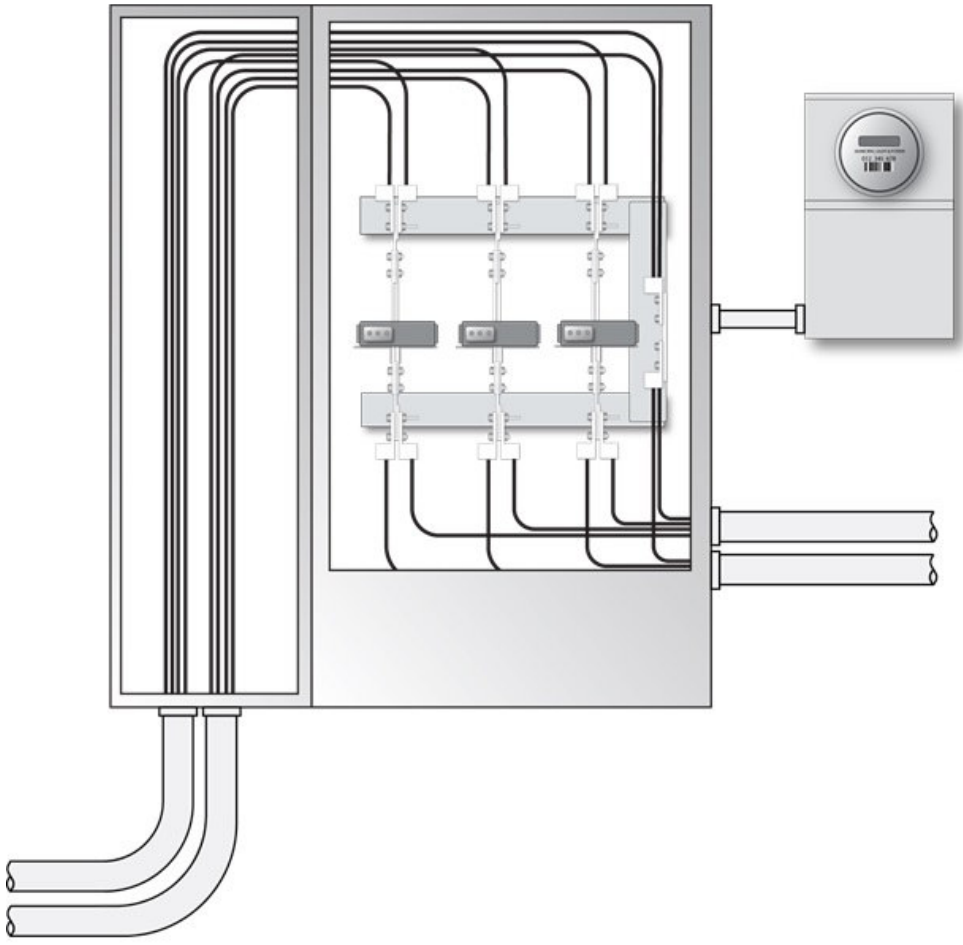

SECTION 500 - INSTALLATION GUIDELINES & SPECIFICATIONS

516 Three-Phase CT Service, Wall-Mounted, 801 Amps to 2,500 Amps

- 516.14 The conduit connecting the CT rated meter socket enclosure and the CT cabinet shall provide a minimum of three (3) inches of clear and unobstructed wiring space on the CT cabinet end. Possible obstructions such as the CT mounting base support brackets or the customer's (load-side) conductors shall be positioned such that the three (3)-inch free wiring space dimension is maintained.
- 516.15 **The preferred mounting height for surface-mounted CT rated meter sockets is sixty-five (65) inches.** The maximum mounting height for surface-mounted CT rated meter sockets is seventy-two (72) inches. The minimum mounting height for surface-mounted CT rated meter sockets is sixty (60) inches. Mounting height is measured from the centerline of the meter socket opening to the finished grade or standing surface immediately in front of the meter.
- 516.16 **The preferred mounting height for wall-mounted CT cabinets on services rated 801 to 1,600 amps is eighty (80) inches.** The maximum mounting height for wall-mounted CT cabinets on services rated 801 to 1,600 amps is eighty-six (86) inches. The minimum mounting height for wall-mounted CT cabinets on services rated 801 to 1,600 amps is seventy-six (76) inches. Mounting height is measured from the top of the CT cabinet to the finished grade or standing surface immediately in front of the CT cabinet.
- 516.17 **The preferred mounting height for wall-mounted CT cabinets on services rated 1,601 to 2,500 amps is eighty-four (84) inches.** The maximum mounting height for wall-mounted CT cabinets on services rated 1,601 to 2,500 amps is ninety (90) inches. The minimum mounting height for wall-mounted CT cabinets on services rated 1,601 to 2,500 amps is eighty (80) inches. Mounting height is measured from the top of the CT cabinet to the finished grade or standing surface immediately in front of the CT cabinet.
- 516.18 No wall-mounted CT cabinet shall be installed with the floor or bottom of the enclosure less than sixteen (16) inches above the finished grade or standing surface immediately in front of the cabinet. Within the Chugach service area the bottom of the enclosure shall be no less than twelve-inches above the finished grade where the CT enclosure access door is a minimum of sixteen-inches above grade.
- 516.19 The customer's (load-side) conductors shall not pass over the top of, in front of, or in any way restrict access to the Utility's (line-side) conductors or CTs. Depending on circumstances, a larger CT cabinet or side gutter compartment may be necessary to meet this requirement.
- 516.20 Placement of the customer's (load-side) conduits is a critical aspect of meeting the requirements of Subsection 516.19. Refer to Subsection 516.22.
- 516.21 The CT cabinet may be configured with a left-hand side gutter compartment or a right-hand side gutter compartment for entry of the Utility's line-side service conductors.
- 516.22 The CT cabinet may be configured with **both** a left-hand side gutter compartment and a right-hand side gutter compartment. One side gutter would be for entry of line-side service conductors and the other side gutter would be for the exit of load-side conductors.

(Continued on page 114)

SECTION 500 - INSTALLATION GUIDELINES & SPECIFICATIONS

516 Three-Phase CT Service, Wall-Mounted, 801 Amps to 2,500 Amps

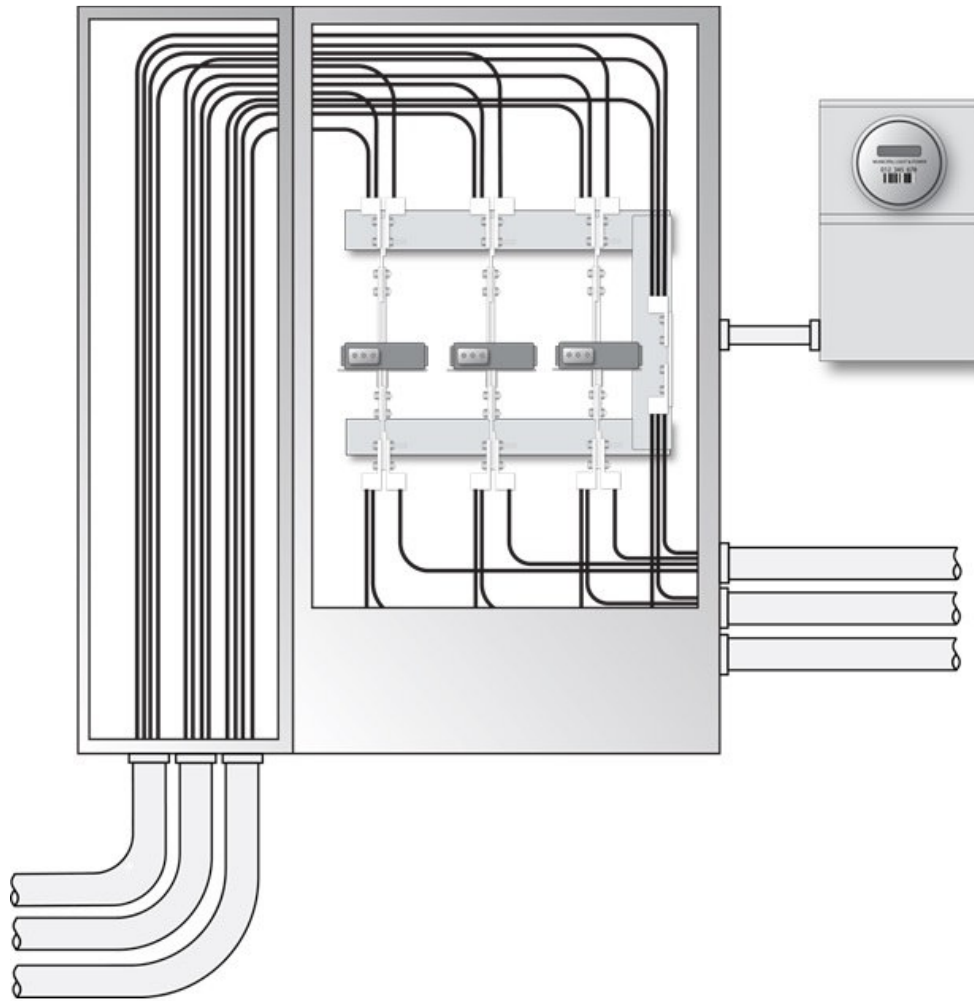

SECTION 500 - INSTALLATION GUIDELINES & SPECIFICATIONS

516 Three-Phase CT Service, Wall-Mounted, 801 Amps to 2,500 Amps

516.23 **Cabinet Dimensions, Three-Phase, 801 to 1,200 amps:** CT cabinets for three-phase services from 801 amps to 1,200 amps shall have minimum dimensions as follows:

- a) Main compartment shall be sixty (60) inches in height, thirty-six (36) inches in width, and fourteen (14) inches in depth.
- b) Side gutter compartment shall be fifty (50) inches in height, fourteen (14) inches in width, and fourteen (14) inches in depth.

516.24 **Cabinet Dimensions, Three-Phase, 1,201 to 1,600 amps:** CT cabinets for three-phase services from 1,201 amps to 1,600 amps shall have minimum dimensions as follows:

- a) Main compartment shall be sixty (60) inches in height, thirty-six (36) inches in width, and fourteen (14) inches in depth.
- b) Side gutter compartment shall be fifty (50) inches in height, twenty-four (24) inches in width, and fourteen (14) inches in depth.

516.25 **Cabinet Dimensions, Three-Phase, 1,601 to 2,500 amps:** CT cabinets for three-phase services from 1,601 amps to 2,500 amps shall have minimum dimensions as follows:

- a) Main compartment shall be sixty-four (64) inches in height, forty (40) inches in width, and fourteen (14) inches in depth.
- b) Side gutter compartment shall be fifty (50) inches in height, twenty-four (24) inches in width, and fourteen (14) inches in depth.

516.26 No connections shall be made in the CT cabinet to supply any other meter or service. CT cabinets **shall not** be used as a junction point to serve other metered circuits.

516.27 Hinged main compartment doors side gutter compartment panels, whether screw cover type or hinged door type, **shall be** properly aligned and adjusted for ease of operation. Doors and panels that require pounding, hammering, and/or prying to remove and/or re-install are **not** acceptable. The Utility will not energize CT rated services with wall-mounted CT cabinets until it has been demonstrated that all hinged main compartment doors and all side gutter compartment panel covers operate in an appropriate manner.

516.28 The customer shall furnish and install service riser conduits for the Utility's (line-side) service conductors meeting the general requirements of Section 520.

516.29 Service riser conduits for all applications rated 201 amps and above shall be rigid metal conduit.

516.30 When using wall-mounted CT cabinets meeting the requirements of Section 615, particular attention must be paid to the arrangement and placement of the service riser conduits. Side gutter compartment dimensions may require the service riser conduits to be stacked rather than spread out horizontally along the structure wall in order to land the conduits within the floor of the side gutter compartment.

516.31 Wall-mounted CT cabinets utilizing side gutter compartments shall have the service riser conduits for the Utility's (line-side) service conductors land on the floor of side gutter compartment only. Service riser conduits for ML&P (line-side) service conductors **shall not** land on the floor of the main compartment.

SECTION 500 - INSTALLATION GUIDELINES & SPECIFICATIONS

516 Three-Phase CT Service, Wall-Mounted, 801 Amps to 2,500 Amps

- 516.32 Service riser conduits shall be secured in place. Service riser conduits **shall be** anchored to the building or structure with a minimum of one (1) conduit strap or clamp (24-inch minimum spacing between clamps).
- 516.33 Service riser conduits extending out from the side gutter compartment of wall-mounted CT cabinets shall be placed so that the top of the conduit on the horizontal section is twenty-four (24) inches below finished grade. Within the Chugach service area the minimum burial depth is thirty (30) inches.
- 516.34 Except as otherwise specified in this book, the horizontal section of the service riser conduits for the Utility's (line-side) service conductors shall extend out from the side gutter compartment no more than forty-eight (48) inches.

SECTION 500 - INSTALLATION GUIDELINES & SPECIFICATIONS

517 Switchboard Service Sections, 201 Amps to 4,000 Amps

- 517.1 All applicable requirements and specifications from other sections of this book apply to these installation guidelines and specifications.
- 517.2 Switchboard service sections and all associated service entrance equipment, including termination sections, metering sections, and meter disconnects shall be placed outdoors on the exterior of the building or structure in accordance with Section 302.
- 517.3 Switchboard service sections and all related components shall meet the general requirements of Section 310.
- 517.4 The customer shall furnish and install a standard switchboard service section with CT compartment meeting the requirements of Sections 616 or 617.
- 517.5 Switchboard service sections rated 201 amps to 1,000 amps shall have a CT compartment meeting the requirements of Section 620.
- 517.6 Switchboard service sections rated 1,001 amps to 3,000 amps shall have a CT compartment meeting the requirements Section 621.
- 517.7 Switchboard service sections rated 3,001 amps to 4,000 amps shall have a CT compartment meeting the requirements Section 622.
- 517.8 Switchboard service sections rated 1,001 amps to 3,000 amps shall have removable bus links and CT supports meeting the requirements Section 623.
- 517.9 Switchboard service sections rated 3,001 amps to 4,000 amps shall have removable bus links and CT supports meeting the requirements Sections 623 for 4-inch bus applications and 624 for 5-inch bus applications.
- 517.10 The switchboard service section shall have underground service termination compartments meeting the requirements of Sections 625 or 626.
- 517.11 The switchboard service section shall have a 15-inch hinged meter panel meeting the requirements of Section 618.
- 517.12 The Switchboard service section shall have an outdoor enclosure meeting the requirements of Section 619.
- 517.13 The switchboard service section shall have underground service terminating facilities meeting the requirements of Section 627.
- 517.14 CT compartment covers for switchboards (hinged meter panels) shall be lockable and shall accept a padlock with a shackle diameter of five-sixteenths (5/16) inch.
- 517.15 The maximum mounting height for a switchboard service section CT rated meter socket is seventy-two (72) inches. The minimum mounting height for a switchboard service section CT rated meter socket is fifty-seven (57) inches. Mounting height is measured from the standing surface immediately in front of the meter socket.

(Continued on page 118)

SECTION 500 - INSTALLATION GUIDELINES & SPECIFICATIONS

517 Switchboard Service Sections, 201 Amps to 4,000 Amps

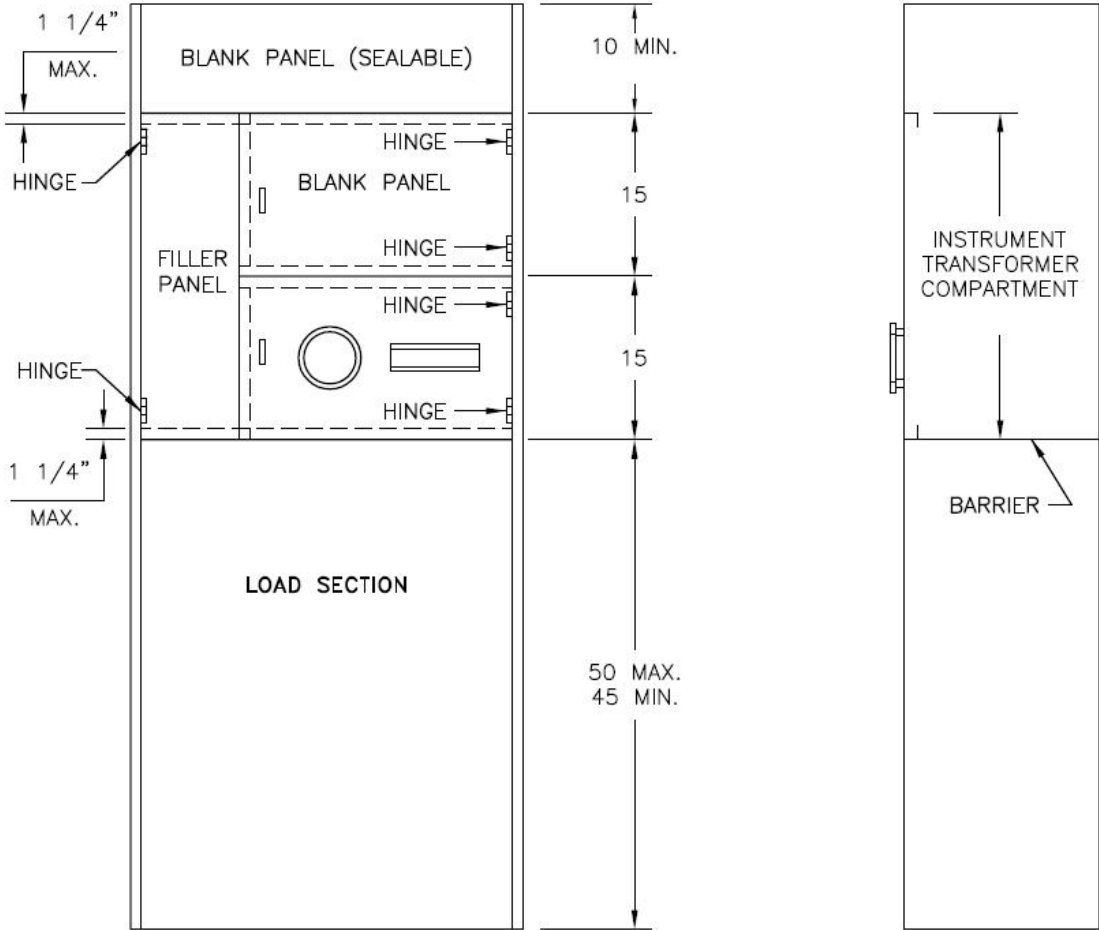

FRONT VIEW

SIDE VIEW

THIS IS A TYPICAL DIAGRAM. THIS DIAGRAM IS NOT TO BE USED AS A DESIGN OR CONSTRUCTION DRAWING. REFER TO SERVICE EQUIPMENT SPECIFICATION SECTIONS 616 THROUGH 626 FOR EQUIPMENT DETAILS RELATED TO SWITCHBOARD SERVICE SECTIONS.

SECTION 500 - INSTALLATION GUIDELINES & SPECIFICATIONS

517 Switchboard Service Sections, 201 Amps to 4,000 Amps

- 517.16 Switchboard service sections shall be placed on a concrete pad suitably configured for delivery of electric service from the Utility. All specifications related to barriers and separation of unmetered conductors or bus (utility line-side) and metered conductors or bus (customer load-side) of switchboard service sections shall extend to the concrete pad; unmetered conductors or bus (utility line-side) and metered conductors or bus (customer load-side) shall not occupy the same space, conduit, raceway, or compartment.
- 517.17 The height of the concrete pad on which the switchboard metering section is placed must be considered when determining meter socket height.
- 517.18 The customer shall furnish and install service riser conduits for the Utility's (line-side) service conductors meeting the general requirements of Section 520.
- 517.19 Service riser conduits for entry of the Utility's (line-side) service conductors into a switchboard service termination section shall have ninety (90)-degree, twenty-four (24)-inch minimum radius conduit elbows (rigid metal conduit only) and each conduit shall extend out from the outside edge of the concrete pad a minimum of twelve (12) inches and a maximum of forty-eight (48) inches.
- 517.20 Service riser conduits extending out from switchboard service sections shall be placed so that the top of the conduit on the horizontal section is twenty-four (24) inches below finished grade. Within the Chugach service area the minimum burial depth is thirty (30) inches.
- 517.21 Service riser conduits for entry of the Utility's (line-side) service conductors into switchboard service sections shall have the conduits placed within the switchboard's concrete mounting pad such that the conduits come up under the appropriate service termination section. Service riser conduits of switchboard service sections shall be placed under no compartment other than the service termination section or compartment. All switchboard service section specifications related to barriers and separation of unmetered conductors or bus (utility line-side) and metered conductors or bus (customer load-side) include the concrete mounting pad and the service riser conduits. This may necessitate stacking of conduits.

RESERVED

SECTION 500 - INSTALLATION GUIDELINES & SPECIFICATIONS

518 Emergency/Standby Systems (Generators)

- 518.1 When incorporating an emergency/standby electrical system (e.g. electrical generator) into the electrical system of a customer's building or structure, the installation shall comply with all applicable requirements of the NEC with any local amendments to the NEC, and with Section 212.
- 518.2 Consultation with an electrician or an electrical engineer will help determine the necessary equipment to be operated under standby or emergency conditions. This will be critical in determining the correct size of a stand-by electrical system (electrical generator) to be purchased.
- 518.3 The Utility recommends that transfer switches for single family residential service installations be installed by a licensed electrical contractor for safety reasons as well as proper application. Transfer switches for all other emergency/standby applications require installation by a licensed electrical contractor as per Municipal Code. All transfer switch installations require a permit and inspection by the Municipality of Anchorage or the State of Alaska for multi-residential triplex (and larger) and all non-residential applications outside of the MOA inspection area and within the Chugach service area.
- 518.4 The Utility will deny service to or disconnect service from any premises or facility that is connected to another electrical system other than the customer's emergency/standby electrical system connected through a Utility approved transfer switch.
- 518.5 The Utility will require a one-line electrical diagram of the proposed installation showing the normal source (utility power), the alternate source (emergency/standby system), and an accurate depiction of the transfer switch employed. The Utility will also require the electrical generator manufacturer's specific ratings and capacities for the unit proposed, the transfer switch manufacturer's specific ratings and capacities for the transfer switch proposed, and a detailed description of transfer switch operation. If the transfer switch is intended for parallel operation (closed-transition type), the customer shall also provide specifications of all interconnecting equipment including, circuit protection (protective relays), instrumentation, measurement, and control equipment.
- 518.6 Transfer switches must be of a design that will ensure that back feed into the Utility's electrical system will be prevented. Transfer switches, both open-transition type and closed-transition type, shall be approved by the Utility prior to installation. The Utility shall make the sole determination as to whether or not an emergency/standby electrical system installation meets the Utility's requirements and provides an appropriate level of protection against back feed into its electrical system.
- 518.7 Manual transfer switches shall be of the double-throw, open-transition type.
- 518.8 Automatic transfer switches shall be the open-transition type except as provided in ML&P Tariff Rule 6.12.5. Within the Chugach service area automatic transfer switches shall be the open-transition type except where a written agreement with Chugach is made for a closed transition automatic transfer switch installation and operation. Automatic transfer switches must provide for manual transfer of customer load. Automatic transfer switches shall have both mechanical and electrical interlocks to prevent parallel operation of the customer's emergency/standby electrical system with the Utility's electrical system. Within the Chugach service area; submit manufacturer supplied documentation denoting (underlined/highlighted and page number references) where the auto-transfer switch manufacturer describes compliance with the manual transfer, mechanical and electrical interlock requirements, to the Chugach Engineering division.

SECTION 500 - INSTALLATION GUIDELINES & SPECIFICATIONS

518 Emergency/Standby Systems (Generators)

- 518.9 Modifying or overriding transfer switches is not acceptable. The Utility will deny service to or disconnect service from any premises or facility with an emergency/standby electrical system that is found to have any modifications made to a transfer switch, unless such modifications are in compliance with the listing of the device by an approved testing laboratory and have been approved in writing by the Utility.
- 518.10 Emergency/standby electrical systems intended for parallel operation (closed-transition type) shall not be installed until the customer has entered into an agreement for operation of closed-transition transfer switches with the Utility. Subsequent to the written agreement with the Utility, and prior to the system being made operational, the customer shall schedule with the Utility a time for initial inspection and testing of the closed-transition transfer switch and emergency/standby electrical system.
- 518.11 Key-type interlock systems employing key cylinders and locking bolts, and ratcheting or pivoting plates that attempt to externally connect two independent circuit breakers in a break-before-make scheme do not satisfy the requirements of ML&P Tariff Rules 6.12.1, 6.12.2, and 6.12.3 and **will not** be allowed.
- 518.12 Meter socket adapter transfer devices **are prohibited** from use on the Utility's system.
- 518.13 Transfer switches, when service rated and when used as the meter disconnect, shall be lockable. Locking provisions shall conform to the requirements of Section 305. Service rated transfer switches shall meet the requirements of Section 306.
- 518.14 This installation guideline and specification shows diagrams for two suggested methods for installation of a double-throw manual transfer switch for a typical single family residence or small commercial service installation.
- 518.15 "Alternative 1" (page 122) requires the transfer switch be the same size as the main disconnect switch or breaker located adjacent to the meter. This transfer switch arrangement is capable of carrying all existing loads under normal conditions. This means that the only limiting factor on the amount of electrical equipment to run simultaneously under emergency conditions is the size of the generator installed. Under emergency conditions, the customer should turn off all circuit breakers in the distribution panel except for those circuits that feed the emergency load.
- 518.16 "Alternative 2" (page 123) allows selected electrical loads to be separated from the main distribution panel in the building and wired into a sub-distribution panel. This reduces the size of the required transfer switch and may reduce total costs. The limitation with "Alternative 2" is that the building's entire electrical system cannot be incorporated into the standby generator circuit.

SECTION 500 - INSTALLATION GUIDELINES & SPECIFICATIONS

518 Emergency/Standby Systems (Generators), Alternative 1

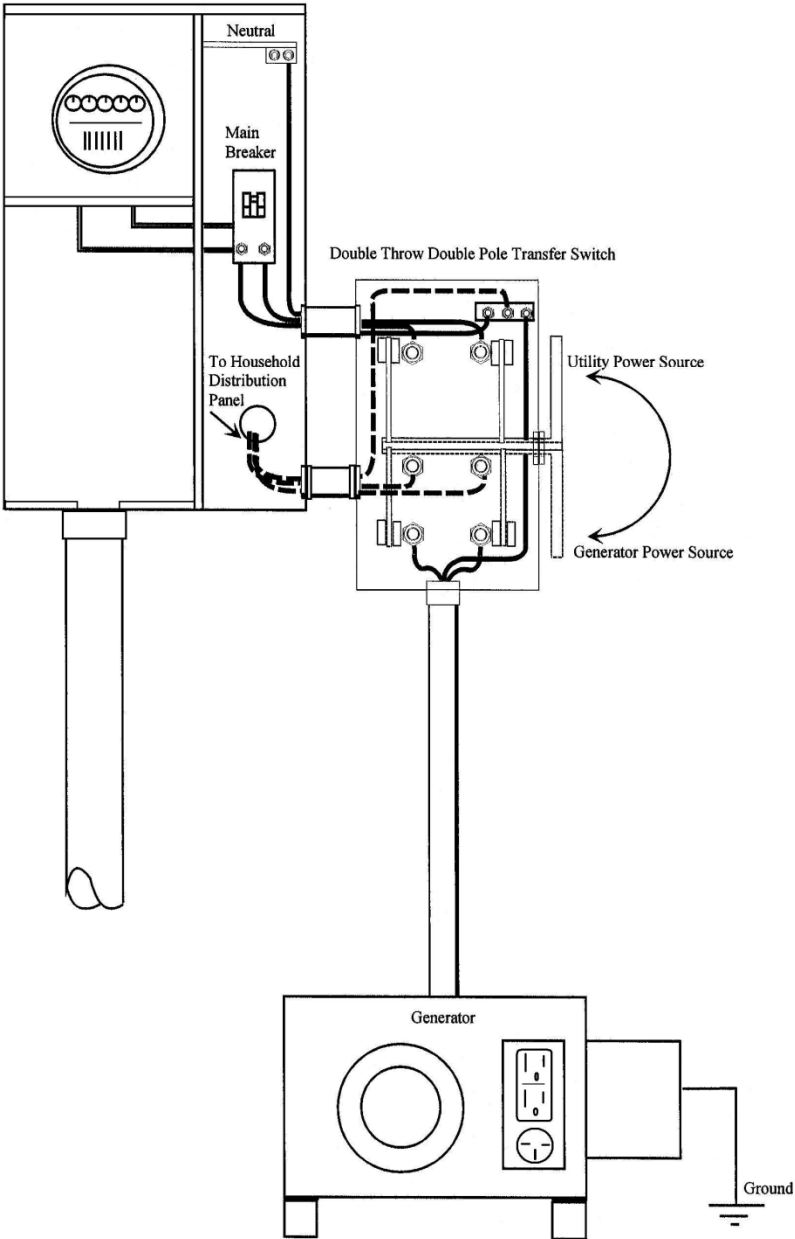

SECTION 500 - INSTALLATION GUIDELINES & SPECIFICATIONS

518 Emergency/Standby Systems (Generators), Alternative 2

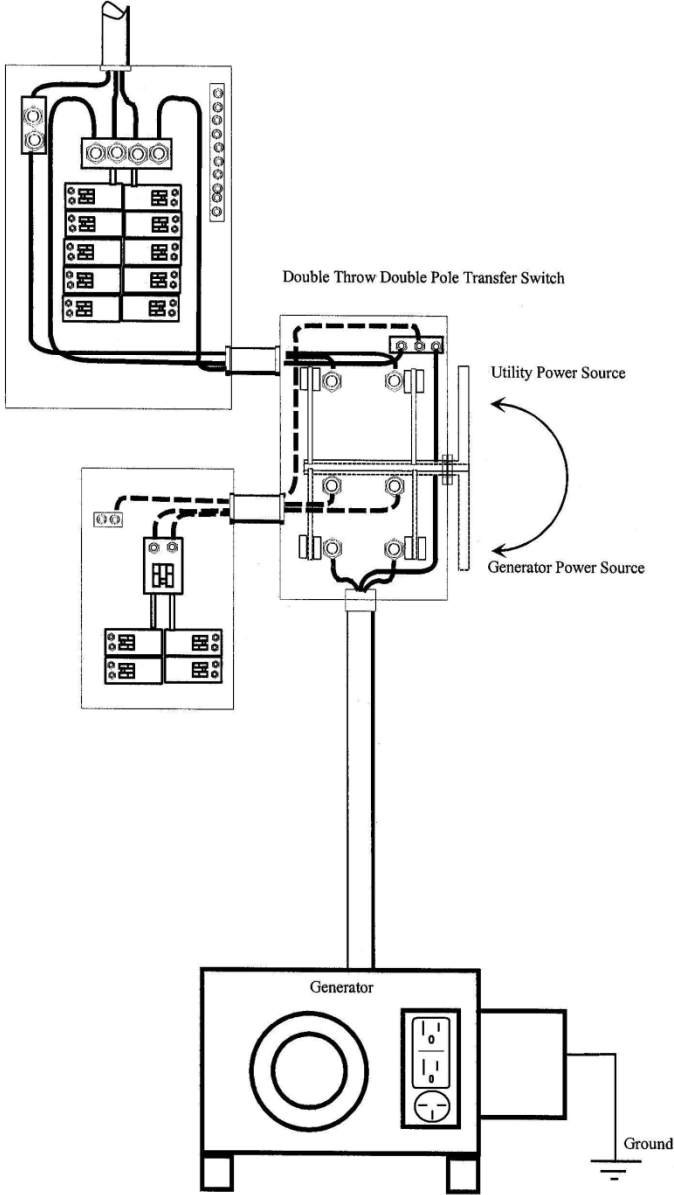

SECTION 500 - INSTALLATION GUIDELINES & SPECIFICATIONS

519 Meter Socket Connection Diagrams

Services Metered Using Direct-Connect Meters

Services metered by direct-connect meters, are illustrated here.

For single-phase services:

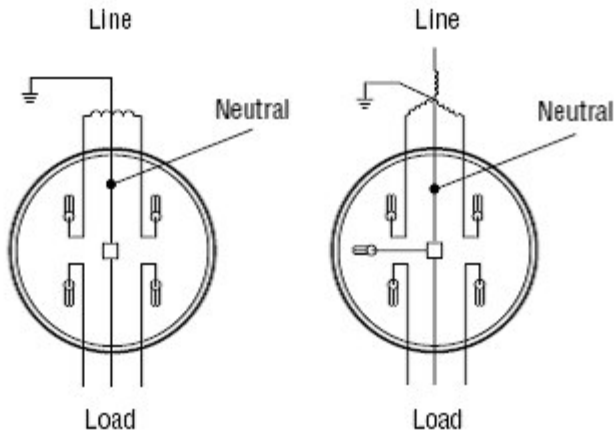

120/240V and 240/480V 3-Wire 120/208V 3-Wire network

For three-phase services:

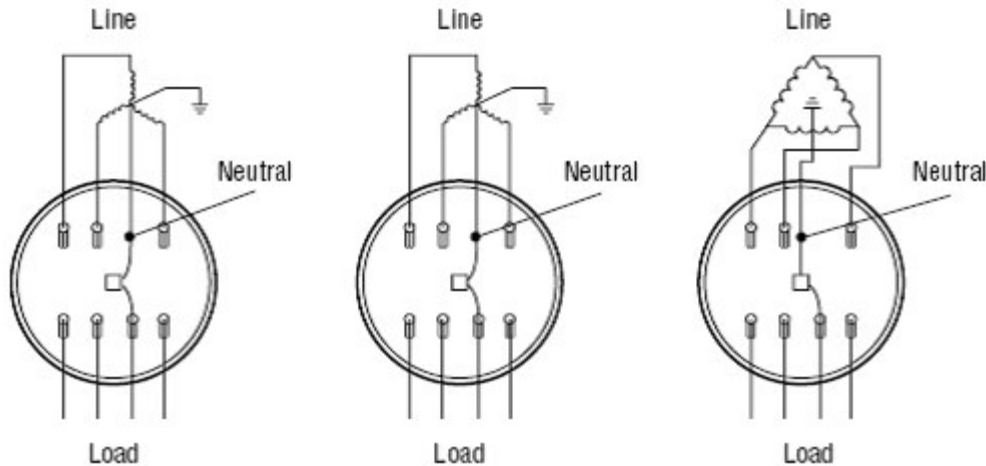

120/208V 4-Wire wye

277/480V 4-Wire wye

120/240V 4-Wire delta

The Utility does not permit new three-phase 120/240V, 240/480V delta services.

SECTION 500 - INSTALLATION GUIDELINES & SPECIFICATIONS

519 Meter Socket Connection Diagrams

Services Metered Using Current Transformers

Services metered using instrument-rated meters and current transformers are shown here.

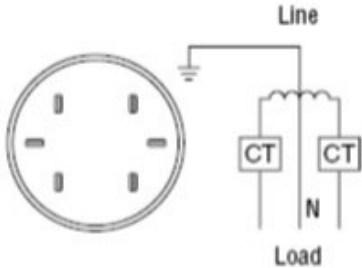

Single-phase, 120/240V 3-wire

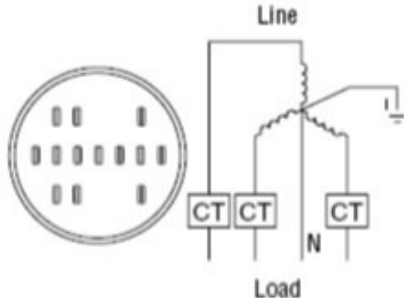

Three-phase, 120/208V 4-wire wye

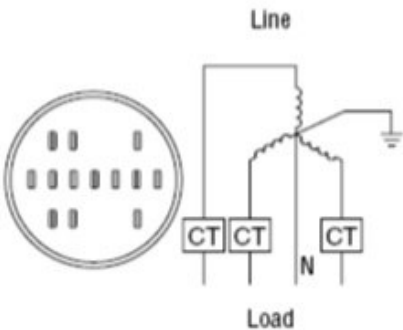

Three-phase, 277/480V 4-wire wye

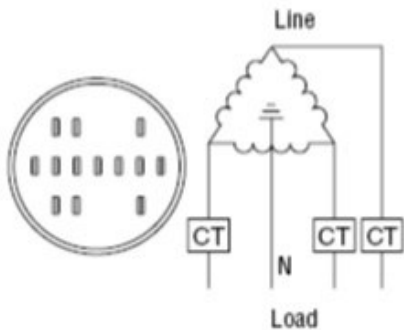

Three-phase, 120/240V 4-wire delta

The Utility does not permit new three-phase 120/240V, 240/480V delta services

SECTION 500 - INSTALLATION GUIDELINES & SPECIFICATIONS

520 Service Riser Conduit Requirements

- 520.1 The installation guidelines and specifications of this section are general in nature and represent typical service applications. It is strongly recommended to consult with the Utility's Engineering Division for specific details regarding the size and number of conduits required for a particular installation. The Utility's Engineering Division may specify conduit sizes smaller or larger than the typical sizes specified in these general guidelines. The Utility's Engineering Division may also specify additional conduits as spares for certain installations.
- 520.2 All residential underground services rated 200 amps or less shall use liquidtight flexible metal conduit for the service riser. The liquidtight flexible metal conduit shall be at least two (2) inches inside diameter and shall extend a maximum of nine (9) feet.
- 520.3 All commercial, industrial, or non-residential underground services, rated 200 amps or less shall use rigid metal conduit at least two (2) inches inside diameter for the service riser.
- 520.4 Self-contained meter sockets for commercial application rated at 200 amps are capable of accepting conduit fittings up to a maximum of three (3) inches. However, the Utility does not stock 3-inch conduit or conduit fittings. Do not use 3-inch conduit or conduit fittings without written approval from the Utility.
- 520.5 All 3-phase, 4-wire, commercial, industrial, or non-residential underground service installations rated at 200 amps shall use rigid metal conduit two (2) inches inside diameter for the service riser.
- 520.6 All underground services rated 201 amps and above shall use rigid metal conduit on the service riser.
- 520.7 All overhead service risers (service masts) shall use rigid metal conduit only and shall be a minimum of two (2) inches inside diameter.
- 520.8 The conduit connecting CT rated meter sockets and CT cabinets or compartments shall be rigid metal conduit only, and shall be one (1) inch or greater inside diameter. Refer to Section 309 for additional CT metering details. EMT and PVC are prohibited in CT meter wiring applications.
- 520.9 The use of electrical metallic tubing and non-metallic conduit on the service riser is prohibited in general. The Utility may approve the use of non-metallic conduit in some applications. Refer to Subsection 520.11 below.
- 520.10 The use of intermediate metal conduit (IMC) as a service riser conduit or for the secondary wiring of CT rated meter installations is prohibited in general.
- 520.11 The use of non-metallic conduit is restricted to those applications where the service riser conduit is completely protected or is not exposed in any way. An example of such an installation is a switchboard service section installation with the switchboard sections installed on a concrete pad and having the service riser conduits placed in the center of the pad. Non-metallic conduit may only be used with written approval from the Utility Engineering Division.
- 520.12 Service riser conduits for entry of the Utility's (line-side) service conductors into termination enclosures, termination compartments, or CT cabinets shall include ninety (90) degree, twenty-four (24) inch minimum radius conduit elbows (rigid metal conduit only) to transition from the horizontal part of the conduit run to the vertical part of the conduit run.

SECTION 500 - INSTALLATION GUIDELINES & SPECIFICATIONS

520 Service Riser Conduit Requirements

- 520.13 Residential underground service installations rated at 200 amps or less using liquidtight flexible metal conduit for the service riser **shall not** include a ninety (90)-degree rigid metal conduit elbow. Where liquidtight flexible metal conduit is used, the flexible metal conduit shall be formed to make the ninety (90)-degree transition from horizontal to vertical.
- 520.14 The horizontal section of each service riser conduit shall extend out from the termination enclosure, termination compartment, or CT cabinet a minimum of twelve (12) inches and no more than forty-eight (48) inches from the enclosure, compartment, or cabinet on which it is landed.
- 520.15 Except where otherwise specified in this book, the horizontal section of each service riser conduit shall be placed so that the top of the conduit is twenty-four (24) inches below finished grade (within the Chugach service area the minimum burial depth is 30-inches). Twenty-four (24) inches is the standard burial depth for ML&P's service conductors rated 480 volts or less, extending to customer's service equipment.
- 520.16 When using wall-mounted CT cabinets meeting the requirements of Section 615 for CT service installations rated from 801 amps to 2,500 amps, particular attention must be paid to the arrangement and placement of the service riser conduits. Side gutter compartment dimensions may require the service riser conduits to be stacked rather than spread out horizontally along the structure wall in order to land the conduits within the floor of the side gutter compartment.
- 520.17 Wall-mounted CT cabinets utilizing side gutter compartments shall have the service riser conduits for the Utility's (line-side) service conductors land on the floor of side gutter compartment only. Service riser conduits for the Utility's (line-side) service conductors **shall not** land on the floor of the main compartment.
- 520.18 Service riser conduits for entry of the Utility's (line-side) service conductors into a switchboard service termination section shall have ninety (90)-degree, 24-inch minimum radius conduit elbows (rigid metal conduit only) and each conduit shall extend out from the outside edge of the concrete pad a minimum of twelve (12) inches and a maximum of forty-eight (48) inches.
- 520.19 Service riser conduits for entry of the Utility's (line-side) service conductors into switchboard service sections shall have the conduits placed within the switchboards' concrete mounting pad such that the conduits come up under the appropriate service termination section. Service riser conduits of switchboard service sections shall be placed under no section or compartment other than the service termination section or compartment. All switchboard service section specifications related to barriers and separation of unmetered conductors or bus (utility line-side) and metered conductors or bus (customer load-side) include the concrete mounting pad and the service riser conduits. This may necessitate stacking of conduits.
- 520.20 No condulets (LB's, LL's or LR's) may be used in the service riser conduit run for the Utility's (line-side) service conductors.
- 520.21 Except where otherwise specified in this book, no junction box may be used as part of the service riser conduit run for the Utility's (line-side) service conductors.
- 520.22 Service riser conduits shall be secured in place. Service riser conduits shall be anchored to the building or structure with a minimum of one conduit strap or clamp (24-inch minimum spacing).

SECTION 500 - INSTALLATION GUIDELINES & SPECIFICATIONS

520 Service Riser Conduit Requirements

- 520.23 Where customers have concerns regarding ground settlement or frost jacking, the Utility is willing to review detailed proposals for the installation of expansion fittings in the vertical section of the service riser conduit run where the conduit lands on fixed equipment. Approval for the use of expansion fittings in a service riser conduit will be in written form specific to the service location and customer proposal. To mitigate vertical riser displacement of flexible metal conduit installations one of the three connection methods is required: 1) an insulated grounding bushing with two 3-1/2" x 2" reducing washers, sandwiching the enclosure floor 2) a 4-bolt threaded hub or 3) an insulated grounding bushing with a 2-inch drilled hole through bottom of enclosure without a knockout provision.
- 520.24 A possible hazardous (classified) location exists in and around the Merrill Field airport complex and International East Subdivision (GAAB landfill). These are former landfill sites, and like any other landfill site, decomposing matter can and does produce many different gasses including nitrogen, oxygen, ammonia, sulfides, carbon monoxide, and methane. The Solid Waste Services department of the Municipality of Anchorage released a reminder memo dated January 1, 2010 regarding the hazardous gasses that may be present in the Merrill Field area. New or remodeled service installations in or near the Merrill Field complex and International East subdivision may be required to install explosion proof fittings on the vertical part of the service riser conduit run.
- 520.25 Refer to Section 508 regarding service riser conduit requirements for commercial service pedestals.

SECTION 500 - INSTALLATION GUIDELINES & SPECIFICATIONS

520 Service Riser Conduit Requirements

Size and Number of Conduits for Typical Applications:

Single-phase, 3-wire, 100 amps, one (1) each, 2-inch inside diameter conduit

Single-phase, 3-wire, 200 amps, one (1) each, 2-inch inside diameter conduit

Single-phase, 3-wire, 201 amps to 800 amps, one (1) each, 4-inch inside diameter conduit

Three-phase, 4-wire, 100 amps, one (1) each, 2-inch inside diameter conduit

Three-phase, 4-wire, 200 amps, one (1) each, 2-inch inside diameter conduit (refer to Subsections 520.4 and 520.5)

Three-phase, 4-wire, 201 amps to 400 amps, one (1) each 4-inch inside diameter conduit

Three-phase, 4-wire, 401 amps to 800 amps, two (2) each, 4-inch inside diameter conduits

Three-phase, 4-wire, 801 amps to 1,200 amps, three (3) each, 4-inch inside diameter conduits

Three-phase, 4-wire, 1,201 amps to 1,600 amps, four (4) each, 4-inch inside diameter conduits

Three-phase, 4-wire, 1,601 amps to 2,000 amps, five (5) each, 4-inch inside diameter conduits

Three-phase, 4-wire, 2,001 amps to 3,000 amps, six (6) each, 4-inch inside diameter conduits

Three-phase, 4-wire, 3,001 amps to 4,000 amps, consult with the Utility's Engineering Division

NOTE: These are general guidelines only; consult with the Utility's Engineering Division for specific details regarding the size and number of conduits required for a particular installation.

SECTION 500 - INSTALLATION GUIDELINES & SPECIFICATIONS

521 Working Space and Clearance Requirements

- 521.1 All metering and service equipment installations shall provide a suitable working space as defined in this installation guideline and specification and shall include an appropriate standing surface and width, depth, height, approach, and side clearance dimensions listed as follows:
- 521.2 **Standing Surface:** A suitable standing surface shall be provided and maintained in front of each metering and service equipment installation. A clear and unobstructed working space shall be provided above this surface. A suitable standing surface is defined as a properly supported concrete pad, asphalt pavement, steel plate, or compacted soil or gravel. The standing surface shall be level and shall have a non-skid walking surface.
- 521.3 **Working Space Width:** The width of the working space shall be at least as wide as the metering and service equipment and sufficient to permit ready access to the metering and service equipment and shall be a minimum of thirty-six (36) inches. A 36-inch horizontal separation, measured from the center of the nearest meter socket or the edge of the CT cabinet (whichever is more restrictive) to the building access door hinge side, is required prevent a door from opening into the service entrance work space (door restraint devices are not acceptable to reduce the door swing radius and reduce this clearance requirement).
- 521.4 **Working Space Depth Up to 240 Volts:** The depth of the working space shall be a minimum of thirty-six (36) inches for services at 120/240 volts single-phase, 120/208 volts three-phase, and 120/240 volts three-phase.
- 521.5 **Working Space Depth Above 240 Volts:** The depth of the working space shall be a minimum of forty-two (42) inches for services at 240/480 volts single-phase and 277/480 volts three-phase. The depth of the working space is measured from the outer surface of the metering and service equipment.
- 521.6 **Working Space Depth, Other Electrical Equipment:** The depth of the working space shall increase to a minimum of forty-eight (48) inches for all services regardless of service voltage level where the outer surface of the metering and service equipment faces other metering and service equipment or other electrical equipment. The depth of the working space is measured from the outer surface of the metering and service equipment to the outer surface of other metering and service equipment or electrical equipment.
- 521.7 **Working Space Height:** The height of the working space shall be equal to the overall height of the metering and service equipment and in no case be less than seventy-eight (78) inches.
- 521.8 **Approach Height:** The approach and/or path to the metering and service equipment shall have a minimum height of seventy-eight (78) inches and a minimum width of thirty-six (36) inches.
- 521.9 **Walking Surface:** The approach and/or path to the metering and service equipment shall have a non-skid walking surface free of obstacles.
- 521.10 **Side Clearance Requirement:** The working space around the meter socket shall include a minimum of ten (10) inches from the centerline of the meter socket opening to the nearest side wall or other obstruction. **This minimum ten (10)-inch side clearance requirement extends to both sides of the meter.**
- 521.11 The working space around the meter socket shall include a minimum of nine (9) inches from the centerline of the meter socket opening to any obstruction above the meter.

SECTION 500 - INSTALLATION GUIDELINES & SPECIFICATIONS

521 Working Space and Clearance Requirements

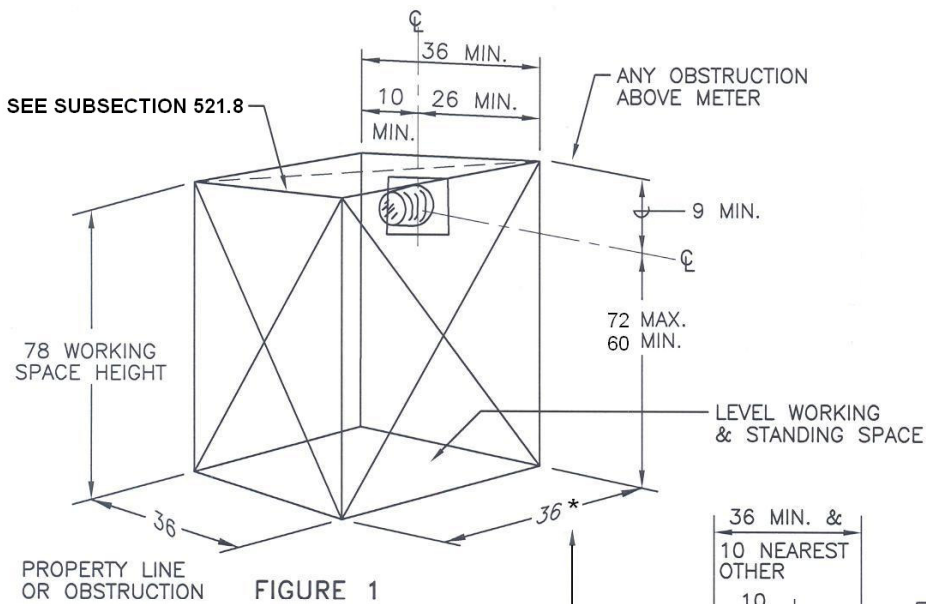

*SEE SUBSECTIONS 521.5 AND 521.6 WHERE MINIMUM DEPTH INCREASES TO 42 INCHES AND 48 INCHES RESPECTIVELY.

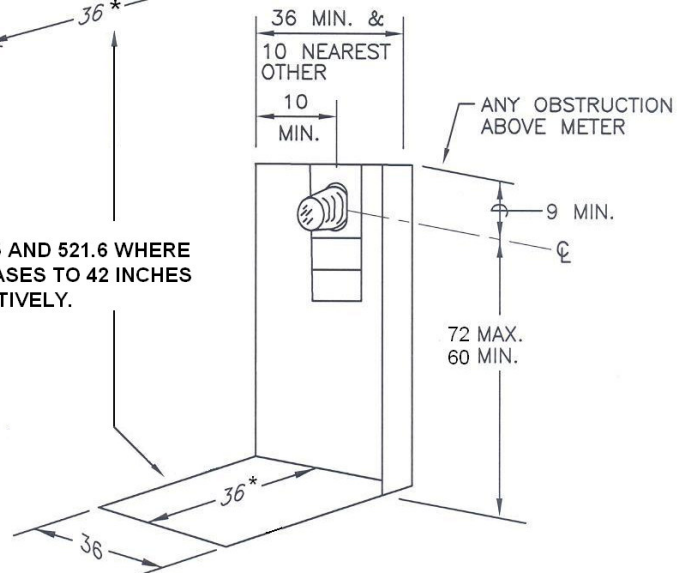

FIGURE 2

ALL DIMENSIONS SHOWN ARE IN INCHES

521.12 Where a cabinet or compartment door or cover swings on hinges, the door or cover shall swing a minimum of ninety (90) degrees and there shall be a minimum of twenty-four (24) inches from the edge of the extended door or cover to any wall, barrier, or obstruction for means of escape.

521.13 Refer to Section 302 for details regarding metering and service equipment location requirements.

521.14 Refer to Section 303 for details regarding side clearance and meter socket height requirements.

SECTION 600 - SERVICE EQUIPMENT SPECIFICATIONS

601 Residential Combination Meter Panel and Service Disconnect

- 601.1 This equipment may be constructed for underground service supply or as a combination panel allowing either overhead or underground service supply applications.
- 601.2 Only one set of terminating facilities shall be provided and located as shown in the following diagram for both underground and overhead service supply applications. The terminating facilities for the service conductors shall be aluminum bodied mechanical lugs with a range of No. 6 AWG through 1/0 AWG for a 125 ampere panel and No. 4 AWG through 250 KCMIL for a 225 ampere panel.
- 601.3 A bonding screw or jumper shall be provided if the neutral terminal is insulated from the enclosure.
- 601.4 A minimum radial clearance of one and one-half (1-1/2) inches shall be provided between the hot bus terminals, hot bus and ground, and hot bus and neutral surfaces. The clearance from the hot bus to the back of the enclosure may be reduced to one (1) inch.
- 601.5 For residential service applications, meter sockets shall have a maximum ampacity rating not less than the ampacity rating of the associated service disconnect. The maximum ampacity rating is 125% of the continuous-duty rating. Within the Chugach service area a minimum meter socket rating of 200 amperes is required for all underground feed services to residential combination meter panels.
- 601.6 The maximum ampacity rating of the service disconnect device used in a residential combination meter panel shall be 225 amperes. Meter panels with 250-amp rated breakers **are not** acceptable.
- 601.7 The Utility does not specify short circuit current ratings for meter disconnect or service disconnect devices. It is the responsibility of the designer and/or installer of the equipment to evaluate and install a device with an AIC rating appropriate for the circumstances.
- 601.8 Meter panels used in underground service applications shall have a separate panel cover for the meter socket section and a separate panel cover for the service conductor termination section. The Utility prohibits the use of meter panels with a single common cover panel for both the meter socket section and the service termination section.
- 601.9 All meter panel covers for compartments or sections containing un-metered conductors shall be sealable or lockable and shall meet the requirements of Section 305.
- 601.10 Single Position Wall-Mounted Meter Panels: **The preferred mounting height for single position wall-mounted meter panels is sixty-five (65) inches.** The maximum mounting height for single position wall-mounted meter panels is seventy-two (72) inches. The minimum mounting height for single position wall-mounted meter panels is sixty (60) inches. Mounting height is measured from the centerline of the meter socket opening to the finished grade or standing surface immediately in front of the meter.
- 601.11 **The preferred mounting height for post-mounted meter panels is fifty (50) inches.** The maximum mounting height for post-mounted meter panels is sixty-five (65) inches. The minimum mounting height for post-mounted meter panels is forty-two (42) inches. Mounting height is measured from the centerline of the meter socket opening to the finished grade or standing surface immediately in front of the meter.
- 601.12 Residential combination meter panel and service disconnect devices shall meet the applicable requirements of Section 307.

SECTION 600 - SERVICE EQUIPMENT SPECIFICATIONS

601 Residential Combination Meter Panel and Service Disconnect

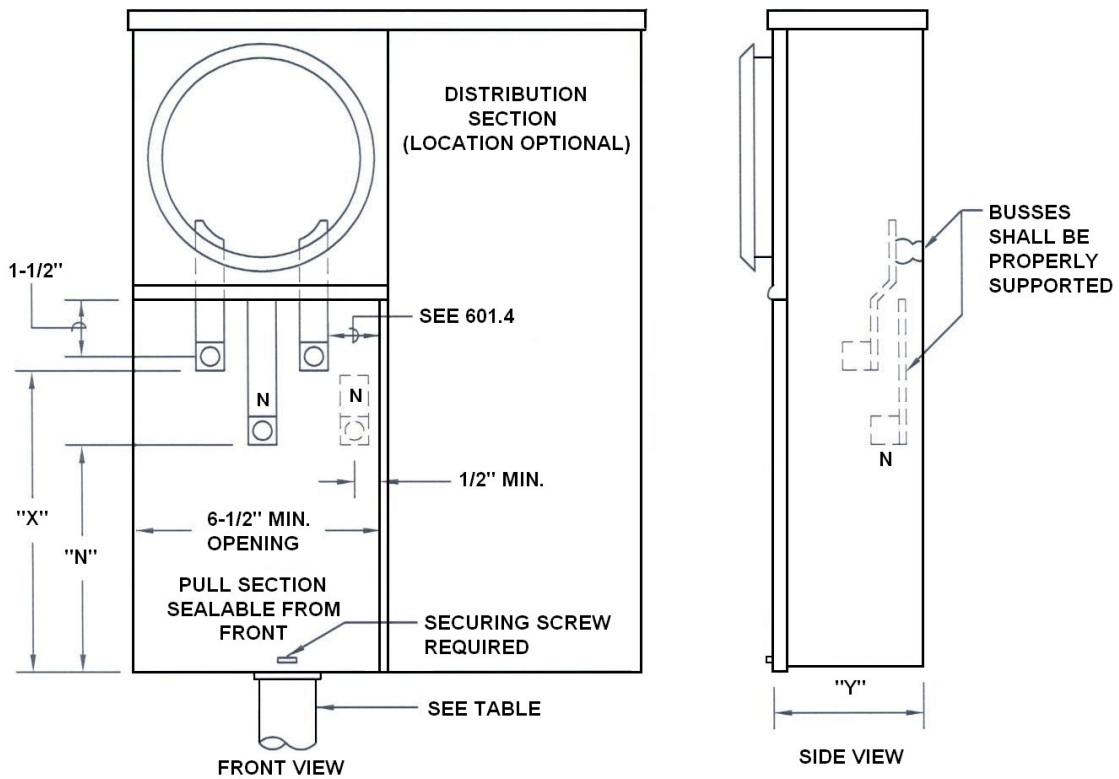

MAXIMUM AMPACITY	"X" MIN. DIM.	"N" MIN. DIM.	"Y" MIN. DIM.	CONDUIT RANGE
125	8"	6"	4"	1-1/4" TO 2-1/2"
225	11"	8-1/2"	5"	1-1/2" TO 3"

SEE 601.5 FOR DETAILS REGARDING MAXIMUM AMPACITY RATINGS AND CONTINUOUS-DUTY RATINGS.

SEE 601.6 FOR MAXIMUM ALLOWABLE AMPACITY RATING OF THE SERVICE DISCONNECT DEVICE.

ALL DIMENSIONS SHOWN ARE IN INCHES.

Within the Chugach service area the 200A meter panel minimum dimensions for the utility (line) side compartment are 7-inches wide, 16-inches high, 5-1/2-inches deep with an 11-inch "X" and "N" terminal height.

601.13 The Utility does not recognize or accept the term "farm panel."

601.14 This service equipment specification is similar to EUSERC Drawing 301. Within the Chugach service area the 200A meter panel minimum dimensions for the utility (line) side compartment are 7-inches wide, 16-inches high, 5-1/2-inches deep with an 11-inch terminal height.

SECTION 600 - SERVICE EQUIPMENT SPECIFICATIONS

602 Combination Safety Socket Panel with Test-Block Bypass and Service Disconnect

- 602.1 The meter panel shown on the following page is typical with the customer's distribution section located to the side of the metering compartment. The distribution section may also be located below the test-block bypass compartment on meter panels configured for overhead supply only.
- 602.2 The meter socket shall be mounted on a rigid support and attached to the meter socket panel.
- 602.3 All panels shall be removable without disturbing adjacent panels.
- 602.4 Minimum test-block bypass compartment access opening dimension shall be as shown in the minimum dimensions table on the following page.
- 602.5 Test-block bypass facilities with rigid insulating barriers shall be furnished installed, and bussed or wired to the meter socket by the manufacturer as follows:
- a) For single-phase, 3-wire, provide two test-blocks with bypasses mounted in the outer positions and a 4-jaw socket. For 120/208 volts, single-phase 3-wire (network) provide two test-blocks with bypasses mounted in the outer positions and a 5-jaw socket connecting the 5th jaw of the socket to the neutral lug with a white No. 12 AWG (minimum size) copper wire.
 - b) For 3-phase, 3-wire, provide three test-blocks with bypasses and a 5-jaw socket. Connect the line and load poles together at the top of the center position test-block with bypass by means of a bus section and connect the bus to the 5th jaw of the socket with a No. 12 AWG (minimum size) copper wire. Color used to identify the wire shall not be white, gray, green, or orange.
 - c) For 3-phase, 4-wire, provide three test-block bypasses and a 7-jaw socket. Connect the 7th jaw of the socket to the neutral lug with a white No. 12 AWG (minimum size) copper wire. For 120/240 volt, 4-wire delta, the right hand test-block bypass shall be the power leg (measures 208 volts to ground) and shall be identified with an orange color.
 - d) Test-block bypass connection sequence shall be LINE-LOAD from left to right and shall be clearly identified in three-quarter (¾)-inch minimum size block letters.
 - e) Cable terminals shall be aluminum-bodied mechanical lugs with a range from No. 6 AWG through 1/0 AWG for 100 ampere rated test-block bypasses and from No. 1/0 AWG through 250 KCMIL for 200 ampere rated test-block bypasses.
- 602.6 There shall be a one and one-half (1-1/2)-inch (minimum separation) dimension measured from the compartment side to the test-bypass block rigid insulating barrier.
- 602.7 There shall be a three (3)-inch (minimum separation) dimension measured from the upper test connector stud (stud "A") to the meter socket cover.

(Continued on page 136)

SECTION 600 - SERVICE EQUIPMENT SPECIFICATIONS

602 Combination Safety Socket Panel with Test-Block Bypass and Service Disconnect

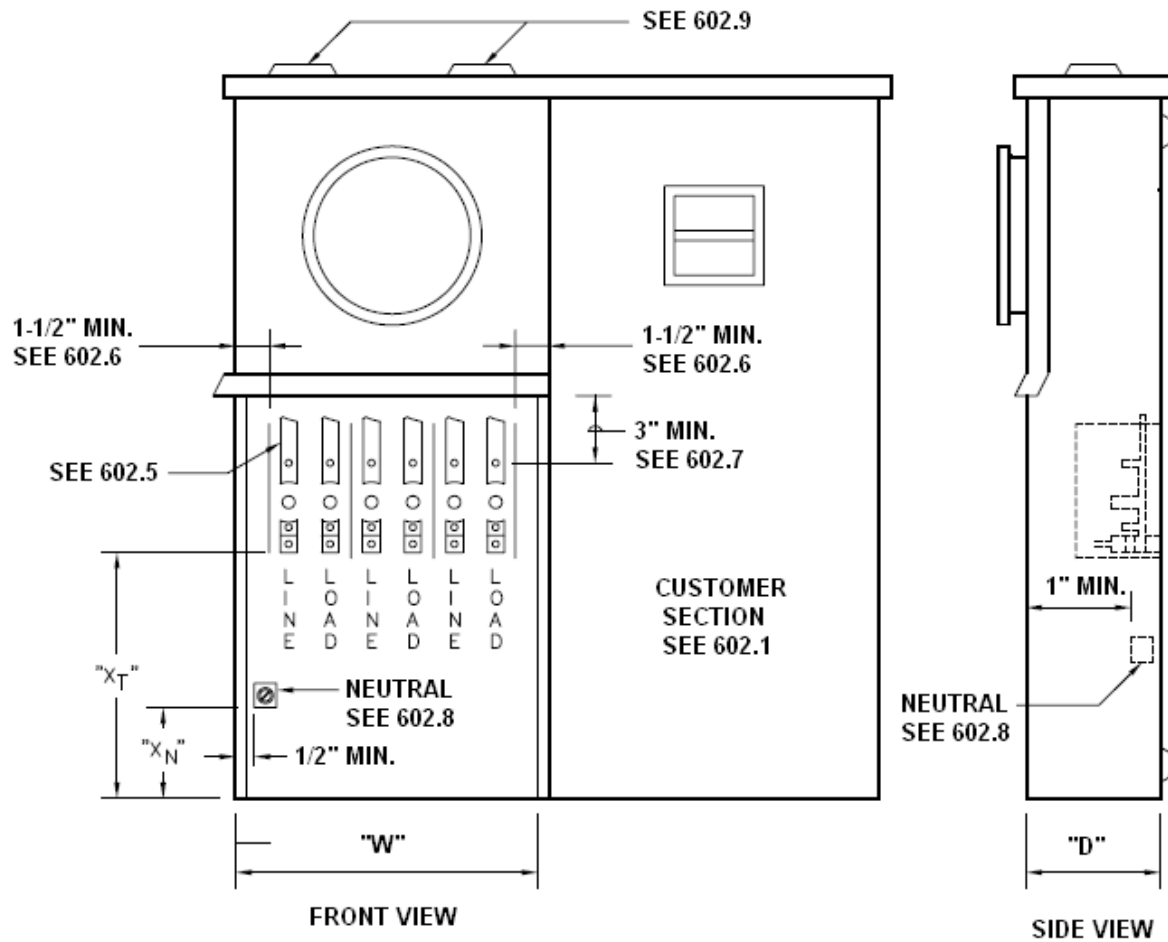

TABLE - MINIMUM DIMENSIONS

PANEL TYPE	PANEL RATING ¹ (AMPERES)	"D"	"W" SEE 602.4	"X _T "	"X _N "
STANDARD	100	4-1/2"	11-1/2"	8"	5"
HEAVY-DUTY	200	6"	13-1/2"	11"	8"

¹CONTINUOUS-DUTY

ALL DIMENSIONS SHOWN ARE IN INCHES

SECTION 600 - SERVICE EQUIPMENT SPECIFICATIONS

602 Combination Safety Socket Panel with Test-Block Bypass and Service Disconnect

- 602.8 The neutral terminal may be provided as follows:
- a) A single mechanical lug or lay-in lug, located on either side or side wall. The lug shall be mounted on a neutral bus bar extending into, and terminating in the customer section.
 - b) Two mechanical lugs or lay-in lugs, located on either side or side wall. The neutral conductor provided from one of the lugs to the neutral bus in the customer section may be factory or field installed.
 - c) For overhead supply only, a single insulated, bondable, vertical, lay-in lug located on either side or side wall with the neutral conductor installed unbroken through the lug and terminating on the neutral bus in the customer section.
- 602.9 Knockouts for the service supply conduit may be cut in the locations shown at the top of the panel.
- 602.10 The Utility does not specify short circuit current ratings for meter disconnect or service disconnect devices. It is the responsibility of the designer and/or installer of the equipment to evaluate and install a device with an AIC rating appropriate for the circumstances.
- 602.11 Safety socket panels with factory installed test-block bypass facilities configured without an integral service disconnect may be used provided that a suitable meter disconnect meeting the requirements of Section 306 is included as part of the service installation.
- 602.12 All access panels for compartments or sections containing un-metered conductors shall be sealable or lockable and shall meet the requirements of Section 305.
- 602.13 Single Position Wall-Mounted Meter Panels: **The preferred mounting height for single position wall-mounted meter panels is sixty-five (65) inches.** The maximum mounting height for single position wall-mounted meter panels is seventy-two (72) inches. The minimum mounting height for single position wall-mounted meter panels is sixty (60) inches. Mounting height is measured from the centerline of the meter socket opening to the finished grade or standing surface immediately in front of the meter.
- 602.14 **The preferred mounting height for post-mounted meter panels is fifty (50) inches.** The maximum mounting height for post-mounted meter panels is sixty-five (65) inches. The minimum mounting height for post-mounted meter panels is forty-two (42) inches. Mounting height is measured from the centerline of the meter socket opening to the finished grade or standing surface immediately in front of the meter.
- 602.15 Combination safety socket panels with test-block bypass facilities and service disconnects shall meet the applicable requirements of Section 307.
- 602.16 This service equipment specification is similar to EUSERC Drawing 305A.

SECTION 600 - SERVICE EQUIPMENT SPECIFICATIONS

RESERVED

SECTION 600 - SERVICE EQUIPMENT SPECIFICATIONS

603 Self-Contained Meters Installed in Switchboards

- 603.1 Test-block bypass facilities with rigid insulating barriers shall be furnished, installed, and wired or bussed to the meter socket by the manufacturer. Connection sequence is LINE-LOAD from left to right.
- 603.2 Metered conductors shall not pass through adjacent metering compartments except in enclosed wireways. To insure proper identification of cables in factory cabled equipment, metered cables (except in the test-block bypass area), shall be either physically barriered or bundled so as to separate them from un-metered cable or permanently marked and isolated from un-metered cables. Physical barriers will not be required if the un-metered conductors are bus.
- 603.3 Meter panels shall be removable with a maximum of two (2) meters per panel. Meter panels shall be provided with a sealing ring for each meter socket and each meter socket shall be rigidly mounted on a support and attached to the meter panel.
- 603.4 Test-block bypass cover panel shall be sealable and fitted with a lifting handle. All panels exceeding sixteen (16) inches in width shall require two (2) lifting handles.
- 603.5 When a neutral is required for metering or testing, an insulated neutral terminal shall be provided behind each test-block bypass cover panel. The terminal shall be readily accessible when the cover panel is removed and shall be individually connected to the neutral bus with a No. 8 AWG (minimum size) copper wire.
- 603.6 A factory installed, full width insulating barrier shall be located at the bottom of each test-block bypass compartment. In addition, a full width and depth isolating barrier shall be located below the bottom test-block bypass compartments and above the load terminals of the meter disconnect devices. If a factory installed rear load wireway is provided, the isolating barrier shall extend back to that wireway. Ventilation openings, when provided, shall not exceed a maximum diameter of three-eighths (3/8) inch. A slot in the isolating barrier provided for the load conductors supplied from the test-block bypass facilities shall be a maximum of one and one-half (1-1/2) inches in depth and may extend to the width of the meter disconnect devices. The slot may not be located in the front six (6) inches of the test-block bypass compartment insulating barrier.
- 603.7 For 3-phase, 4-wire, connect the 7th jaw of meter socket to the body of the neutral lug with a white No. 12 AWG (minimum size) copper wire.
- 603.8 For 3-phase, 4-wire delta, identify the right hand test-block bypass (2 poles) as the power leg (wild-leg). This identification is to be orange in color.
- 603.9 For 3-phase, 3-wire, install bus to connect line and load poles together at top of center test-block bypass and connect the 5th jaw of meter socket to this bus using a No. 12 AWG (minimum size) copper wire. Color used to identify the wire shall not be white, gray, green, or orange.
- 603.10 For Single-phase, 3-wire, omit center test-block bypass.
- 603.11 For single-phase, 3-wire, 120/208 volt circuits, omit center test-block bypass and connect the 5th jaw of the meter socket to the body of neutral lug with a white No. 12 AWG (minimum size) copper wire.
- 603.12 Separate line and load conductors shall be installed by the contractor or manufacturer for each meter socket.

(Continued on page 140)

SECTION 600 - SERVICE EQUIPMENT SPECIFICATIONS

603 Self-Contained Meters Installed in Switchboards

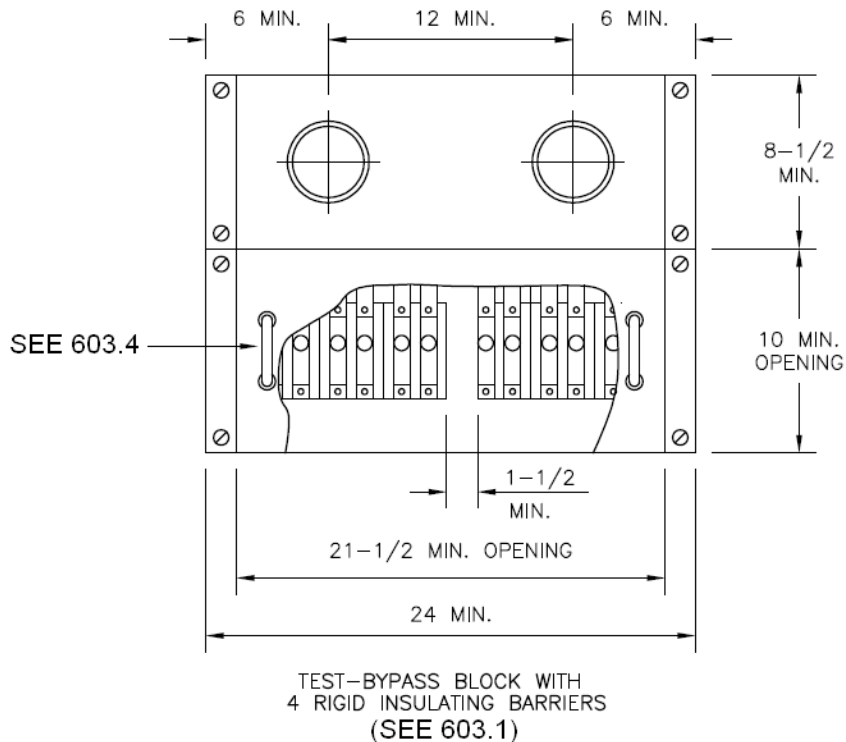
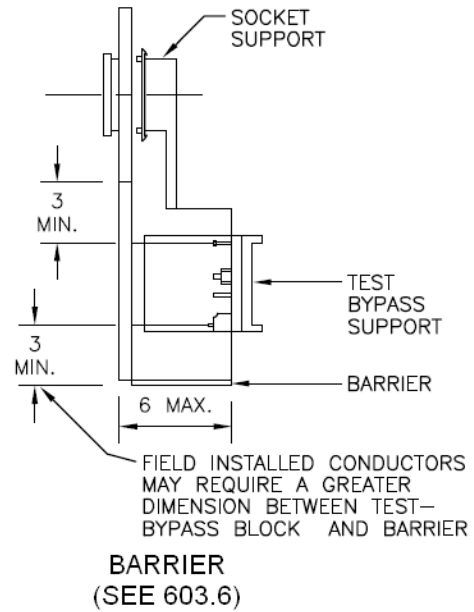
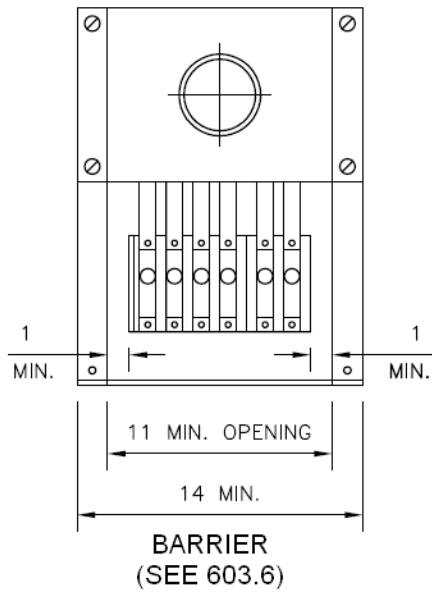

ALL DIMENSIONS SHOWN ARE IN INCHES

SECTION 600 - SERVICE EQUIPMENT SPECIFICATIONS

603 Self-Contained Meters Installed in Switchboards

- 603.13 Each line and load position shall be clearly identified by three-quarter (3/4)-inch minimum block-letter labeling.
- 603.14 All access panels for compartments or sections containing un-metered conductors shall be sealable or lockable.
- 603.15 Self-contained meters installed in switchboards shall meet the applicable requirements of Sections 307, 308, and 310.
- 603.16 This service equipment specification is similar to EUSERC Drawing 306.

SECTION 600 - SERVICE EQUIPMENT SPECIFICATIONS

RESERVED

SECTION 600 - SERVICE EQUIPMENT SPECIFICATIONS

604 Commercial Hinged-Top Service Pedestal

- 604.1 The meter panel shall be provided with a sealing ring and the meter socket shall be rigidly mounted on a support and attached to the meter panel. Meter sockets used in commercial service pedestal applications will be ring type; ringless sockets are not acceptable. Meter height is measured from the center of the meter socket to the finished grade or standing surface immediately in front of the meter. Refer to Subsections 604.13 and 604.15.
- 604.2 The meter socket shall be enclosed and the enclosing cover shall be:
- a) Hinged to allow the top and front to be rotated back as one unit to expose the metering compartment. The "A" dimension does not apply (meter compartment side panels that are fixed in place obstruct the meter socket side clearance and are not allowed). Partial side wall designs (that do not obstruct the meter socket) may be acceptable and require written approval by the Utility in advance of installation. The lifting force required to open the cover shall not exceed twenty-five (25) pounds.
 - b) Equipped with a lifting handle.
 - c) Sealable and lockable with a padlock having a shackle diameter of five-sixteenths (5/16) inch.
 - d) Provided with a demand reset cover with a viewing window (See Fig. 3). The reset cover shall be sealable and lockable with a padlock having a shackle diameter of five-sixteenths (5/16) inch.
 - e) Equipped with a latch or locking device designed to secure the hinged cover in the open position.
- 604.3 Test-block bypass compartment covers shall be sealable and provided with a lifting handle. Covers exceeding sixteen (16) inches in width shall require two (2) lifting handles.
- 604.4 Test-block bypass facilities with rigid barriers shall be furnished, installed and wired or bussed to the meter socket by the manufacturer. Connection sequences shall be LINE-LOAD from left to right and clearly identified by three-quarter (3/4)-inch minimum block-letter labeling.
- 604.5 Test-block bypass facilities shall be installed with the following clearances:
- a) Three (3) inches of vertical clearance from the upper test connector stud to the upper compartment access opening and three (3) inches from the center of the cable terminal screw to the lower compartment access opening.
 - b) One and one-half (1-1/2) inches of side clearance from the rigid insulating barriers to the compartment sides and one (1) inch to the compartment access opening.
- 604.6 When a neutral is required for metering or testing, an insulated neutral terminal shall be provided behind the test-block bypass compartment cover. The terminal shall be readily available when the cover is removed and shall be connected to the neutral terminal in the pull section by a No. 8 AWG (minimum size) copper wire.

(Continued on page 144)

SECTION 600 - SERVICE EQUIPMENT SPECIFICATIONS

604 Commercial Hinged-Top Service Pedestal

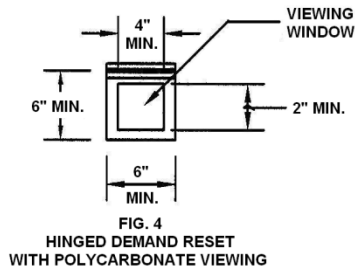
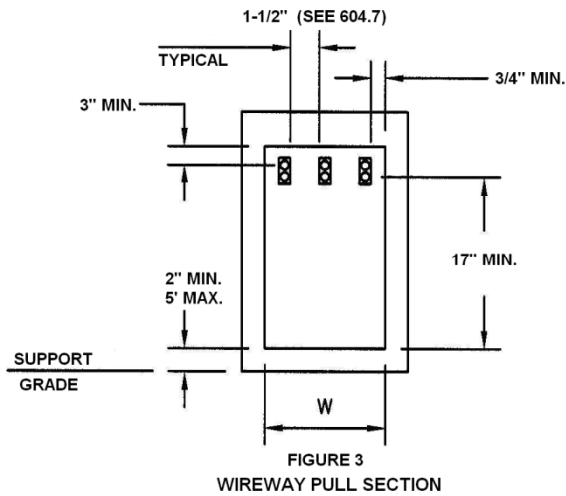
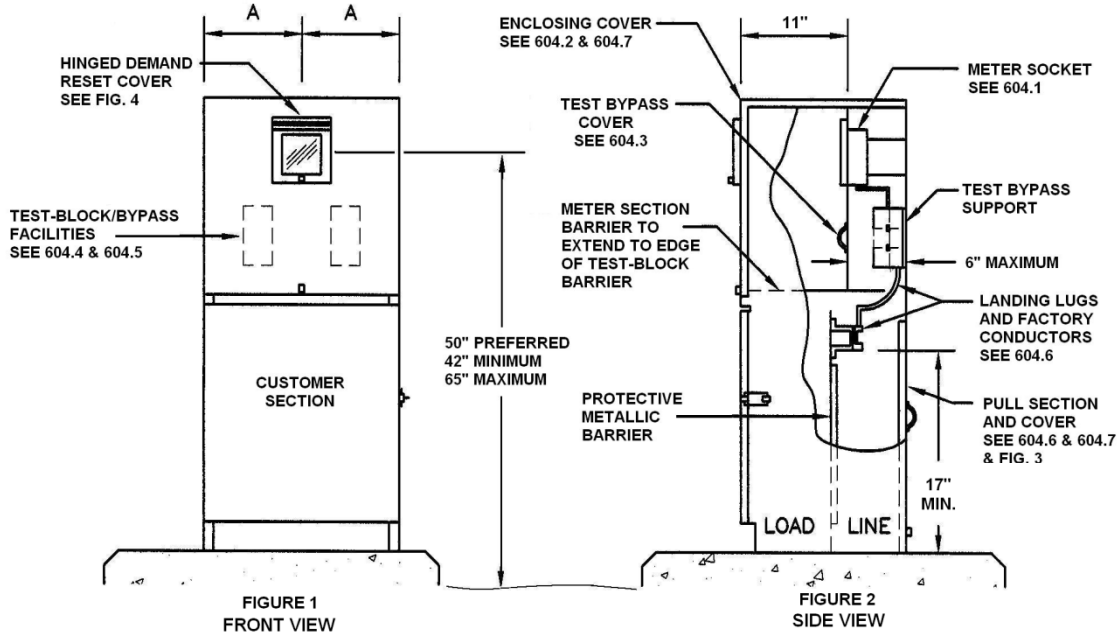

TABLE 1 - MINIMUM DIMENSIONS

SERVICE	W *	A **
1 PHASE	10-1/2"	10"
3 PHASE	12-1/2"	

* SEE 604.6
 ** SEE 604.2

ALL DIMENSIONS SHOWN ARE IN INCHES

SECTION 600 - SERVICE EQUIPMENT SPECIFICATIONS

604 Commercial Hinged-Top Service Pedestal

604.7 The terminating pull section shall:

- a) Comply with minimum dimensions shown in Table 1 of the diagram on page 143, be equipped with lifting handles, and accept a minimum three (3)-inch conduit. The "W" dimension is measured between the access opening return flanges.
- b) Be equipped with aluminum-bodied, pressure type lugs, with a range of No. 6 AWG through 250 KCMIL for termination of the service supply conductors. Insulated cable or bus shall be installed between the termination lugs and the test-block bypass facilities.
- c) A one and one-half (1-1/2) inch minimum spacing shall be provided between the energized lugs or bussing. The one and one-half (1-1/2) inch spacing may be reduced if rigid insulating barriers (1/16 inch minimum thickness) are provided and which extend a minimum of one-half (1/2) inch beyond any exposed energized part when the minimum wire size is installed.
- d) Have a protective metal barrier (16-gauge minimum thickness) provided between the pull section and the customer section. The barrier shall provide a one-quarter (1/4)-inch minimum clearance between the customer section wall and barrier to prevent damage by screws and bolts protruding into the pull section area.

604.8 The utility pull section cover shall be equipped with a lifting handle and be sealable and lockable with a padlock having a shackle diameter of five-sixteenths (5/16) inch.

604.9 Internal equipment attached to the outer walls of the enclosure shall be secured in place with devices that may not be loosened from the outside. Screws or bolts requiring special tools for installation or removal are not acceptable.

604.10 The meter disconnect (circuit breaker) used in commercial service pedestal applications shall be clearly identified and shall be easily distinguished from other circuit breakers present in the customer section.

604.11 Commercial service pedestals used in the Utility's service area shall be the hinged-top design. Fixed-top design commercial service pedestals are prohibited from use on the Utility's system.

604.12 Meter sockets used in commercial service pedestal applications shall be equipped with the safety socket feature and factory installed test-block bypass facilities.

604.13 **The preferred mounting height for commercial service pedestals is fifty (50) inches.** The maximum mounting height for commercial service pedestals is sixty-five (65) inches. The minimum mounting height for commercial service pedestals is forty-two (42) inches. Mounting height is measured from the centerline of the meter socket opening to the finished grade or standing surface immediately in front of the meter. See Subsection 604.15.

604.14 The customer shall furnish and install a suitable concrete mounting base for the commercial service pedestal. The concrete mounting base shall be approved by the Utility.

604.15 The concrete base or pad on which a commercial service pedestal is mounted plays a critical role in meeting mounting height requirements. Mounting height **is** measured from the centerline of the meter socket opening to the finished grade or standing surface immediately in front of the meter. Mounting height **is not** measured from the top of the concrete base on which the commercial service pedestal is mounted. The height of the concrete mounting base **must be included** when determining the mounting height in a commercial service pedestal installation.

SECTION 600 - SERVICE EQUIPMENT SPECIFICATIONS

604 Commercial Hinged-Top Service Pedestal

- 604.16 Service riser conduits for entry of the Utility's (line-side) service conductors into commercial service pedestals shall be placed within the commercial service pedestal's concrete mounting base such that the conduits come up under the utility service conductor termination section or compartment. Service riser conduits **shall not** be placed in a section or compartment other than the service termination section or compartment.
- 604.17 The horizontal section of each service riser conduit shall extend out from the termination section or compartment a minimum of twelve (12) inches and no more than forty-eight (48) inches from the outside edge of the concrete base on which the commercial service pedestal is mounted.
- 604.18 Except where otherwise specified in this book, the horizontal section of each service riser conduit shall be placed so that the top of the conduit is twenty-four (24) inches below finished grade. Within the Chugach service area the minimum burial depth is thirty (30) inches.
- 604.19 Commercial hinged-top service pedestals shall meet the applicable requirements of Section 307.
- 604.20 Refer to Section 508 for commercial service pedestal installation guidelines and specifications.
- 604.21 This service equipment specification is similar to EUSERC Drawing 308.

SECTION 600 - SERVICE EQUIPMENT SPECIFICATIONS

605 CT Rated Meter Socket

- 605.1 All section covers shall be independently removable. The upper cover **shall be** non-removable when the meter is in place. The lower cover **shall be** sealable and permanently labeled: "DO NOT BREAK SEALS, NO FUSES INSIDE."
- 605.2 The CT rated meter socket shall include terminal lugs with a conductor range from No. 14 AWG to No. 10 AWG, meter jaws, and test switch mounting provisions.
- 605.3 The CT rated meter socket shall accommodate a covered test switch with test switch cover sealing provisions. The test switch mounting provisions shall be designed to accept a covered test switch with a depth (the dimension from the rear edge of the test switch base to the top of the cover sealing stud) of no less than three and three-eighths (3-3/8) inches. The lower cover of the meter socket shall seat fully with a covered test switch in place.
- 605.4 The test switch mounting provisions of the CT rated meter socket shall be designed to accept a 10-pole test switch with a base dimension of nine-and-one-half (9-1/2) inches in width.
- 605.5 Removable test switch perch plates may require an offset bend in order to accommodate test switches with sealable covers. If an offset plate is supplied to meet covered test switch requirements, the requirement for the three-quarter (3/4)-inch wire pulling space behind the perch plate **shall be** waived.
- 605.6 The conduit connecting a CT rated meter socket to its CT cabinet shall land on one of the factory supplied knockouts of the meter socket enclosure below the test switch perch area only.
- 605.7 The Utility shall furnish and install the test switch and CT wiring. If the customer provides a pre-wired socket, the Utility shall remove the customer supplied test switch and associated wiring and return it to the customer.
- 605.8 The panel cover for the test switch compartment shall be sealable or lockable.
- 605.9 **The preferred mounting height for wall-mounted CT rated meter sockets is sixty-five (65) inches.** The maximum mounting height for wall-mounted CT rated meter sockets is seventy-two (72) inches. The minimum mounting height for wall-mounted CT rated meter sockets is sixty (60) inches. Mounting height is measured from the centerline of the meter socket opening to the finished grade or standing surface immediately in front of the meter.
- 605.10 **The preferred mounting height for post-mounted CT rated meter sockets is fifty (50) inches.** The maximum mounting height for post-mounted CT rated meter sockets is sixty-five (65) inches. The minimum mounting height for post-mounted CT meter sockets is forty-two (42) inches. Mounting height is measured from the centerline of the meter socket opening to the finished grade or standing surface immediately in front of the meter.
- 605.11 This service equipment specification is similar to EUSERC Drawing 339.

SECTION 600 - SERVICE EQUIPMENT SPECIFICATIONS

605 CT Rated Meter Socket

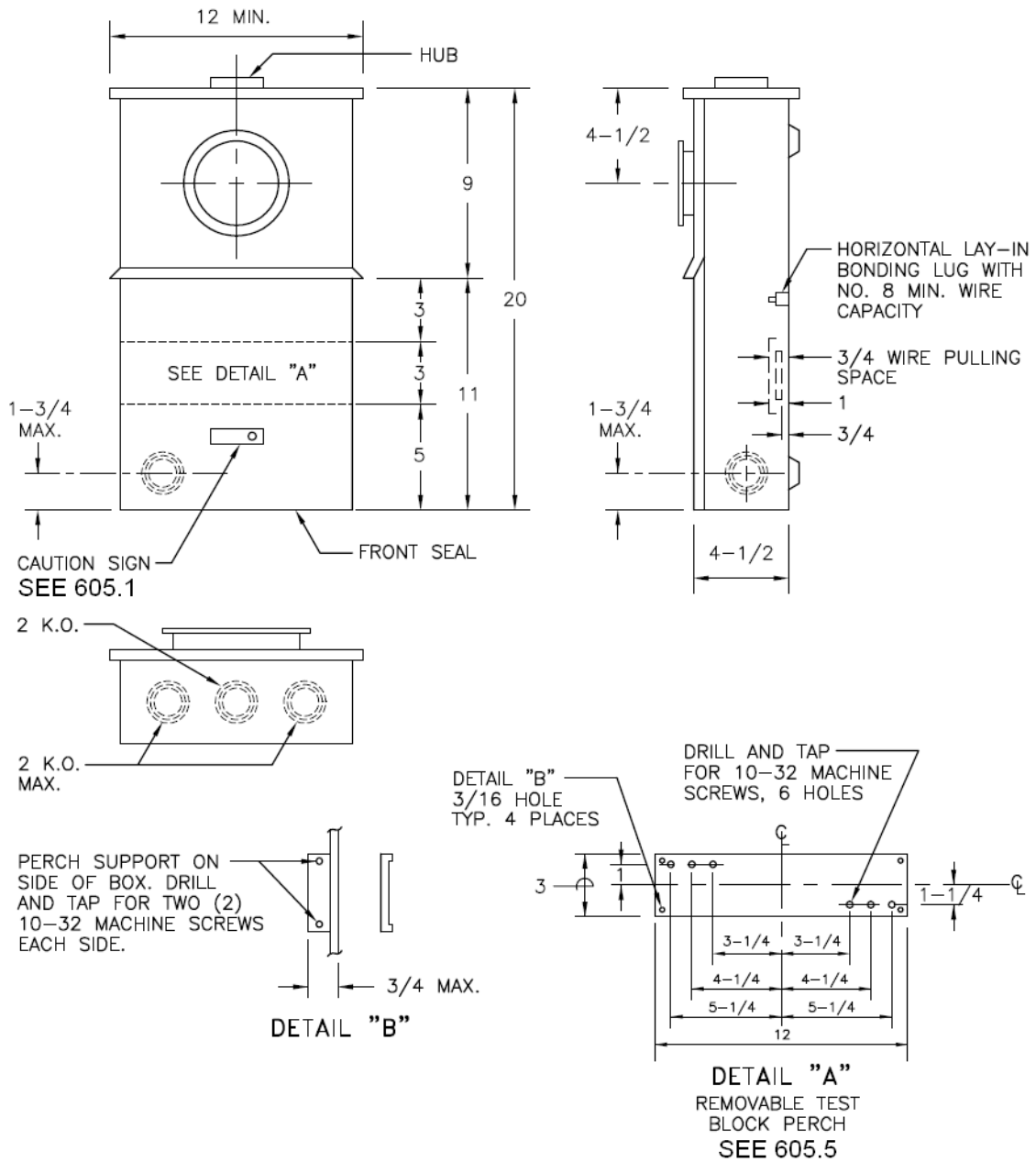

ALL DIMENSIONS SHOWN ARE IN INCHES

SECTION 600 - SERVICE EQUIPMENT SPECIFICATIONS

606 Combination Residential Multi-Meter Panels, 6-Meter Maximum

606.1 Pull section covers shall be:

- a) Independent of other service equipment and removable without disturbing adjacent panels.
- b) Sealable, provided with two (2) lifting handles, and be limited to nine (9) square feet in area.

606.2 Terminating facilities for service supply conductors shall be provided as follows:

- a) For equipment rated 200 amperes (Figures 1 and 2), terminations may be aluminum-bodied, mechanical lugs with a range from No. 4 AWG through No. 250 KCMIL. See Section No. 601 for termination clearance and spacing requirements.
- b) For equipment rated 201 amps to 600 amps (Figures 3 and 4), terminations shall be two 1/2-inch steel bolts as shown. The terminating facilities of equipment rated from 201 amps to 600 amps shall meet the terminating facility requirements of Section 627.

606.3 The neutral terminating position shall be identified. A bonding screw or jumper shall be provided if the neutral terminal is insulated from the enclosure.

606.4 For equipment rated up to 200 amperes, the neutral termination height may be reduced to eight and one-half (8-1/2) inches.

606.5 Cross bussing of a different phase or potential installed behind or below any terminating position shall be fully insulated or barriered. Insulating barriers shall be rigid, non-flammable, rated for the line voltage, resistant to puncture or damage by impact and attached with non-conductive fasteners.

606.6 The minimum pull section access opening ("W") is measured between the left side and right side return flanges.

606.7 Combination residential multi-meter panels shall meet the meter socket and clearance requirements of Section 607.

606.8 The maximum mounting height for multi-metering panels is seventy-five (75) inches. The minimum mounting height for multi-metering panels is thirty-three (33) inches. Mounting height is measured from the centerline of the meter socket opening to the finished grade or standing surface immediately in front of the meters. The 75-inch maximum height applies to the uppermost socket opening and the 33-inch minimum height applies to the lowermost socket opening of the multi-metering equipment. This multi-metering height requirement applies to both commercial and residential applications.

606.9 This service equipment specification is similar to EUSERC Drawing 342.

SECTION 600 - SERVICE EQUIPMENT SPECIFICATIONS

606 Combination Residential Multi-Meter Panels, 6-Meter Maximum

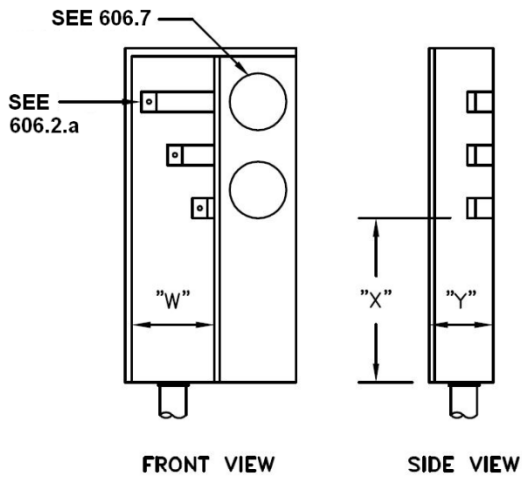

FIGURE 1

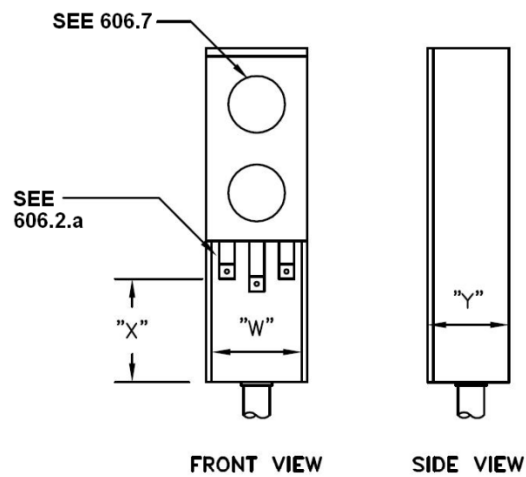

FIGURE 2

TYPICAL SERVICE TERMINATING ARRANGEMENTS. TWO (2) METERS (0-200 amp)

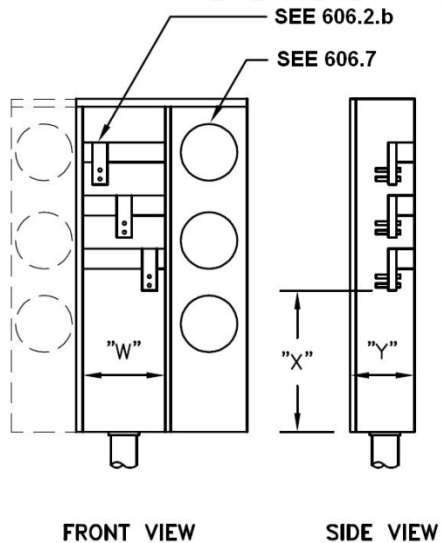

FIGURE 3

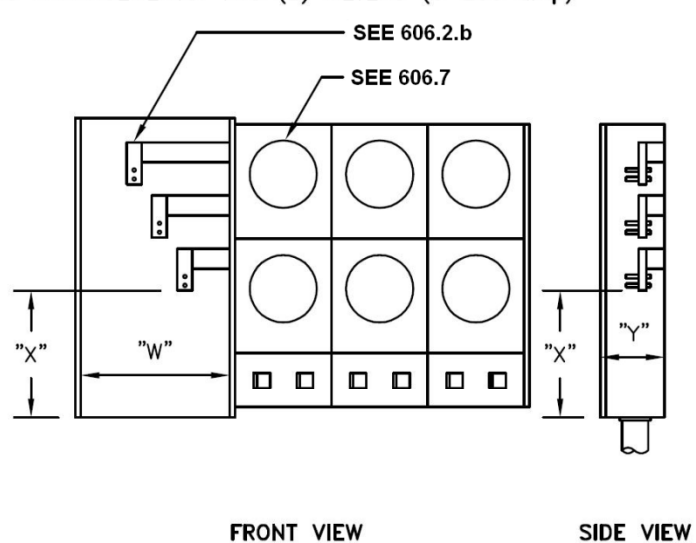

FIGURE 4

TYPICAL SERVICE TERMINATING ARRANGEMENTS. 3 - 6 METERS (201-600 AMPS)

EQUIPMENT RATING	"W"	"Y"	"X"
Amperes (Continuous)	SEE 606.6		SEE 606.3 & 606.4
0-200 AMPS	6-1/2 MIN.	5-1/2 MIN.	11 MIN.
201-600 AMPS	10-1/2 MIN.	6 MIN.	22 MIN.

ALL DIMENSIONS SHOWN ARE IN INCHES

SECTION 600 - SERVICE EQUIPMENT SPECIFICATIONS

607 Clearances for Residential Multi-Metering Installations

- 607.1 Where an adjacent wall or other obstruction extends more than eleven (11) inches perpendicular from the face of the meter panel, a ten (10) inch minimum dimension to the meter socket axis is required. For obstructions extending eleven (11) inches or less from the meter panel, the side clearance shall conform to that of Dimension "B".
- 607.2 Panels shall be removable to provide access to the customer's equipment with the Utility's meters and tamperproof sealing rings in place. When there is more than one meter socket per panel, the minimum meter cutout opening, as detailed in Figure 1 on the following page shall apply.
- 607.3 Underground landing lugs shall not be placed under any socket cover.
- 607.4 Dimension "B" shall be increased by the amount that the main switch door, including operating handle, reduces the clearance when opened ninety (90) degrees.
- 607.5 The maximum mounting height for multi-metering panels is seventy-five (75) inches. The minimum mounting height for multi-metering panels is thirty-three (33) inches. Mounting height is measured from the centerline of the meter socket opening to the finished grade or standing surface immediately in front of the meters. The 75-inch maximum height applies to the uppermost socket opening and the 33-inch minimum height applies to the lowermost socket opening of the multi-metering equipment. This multi-metering height requirement applies to both commercial and residential applications.
- 607.6 Removable meter panel covers shall not exceed six (6) square feet in area.
- 607.7 Distribution conductors shall be barriered from the metering compartment.
- 607.8 This service equipment specification is similar to EUSERC Drawing 353.

SECTION 600 - SERVICE EQUIPMENT SPECIFICATIONS

607 Clearances for Residential Multi-Metering Installations

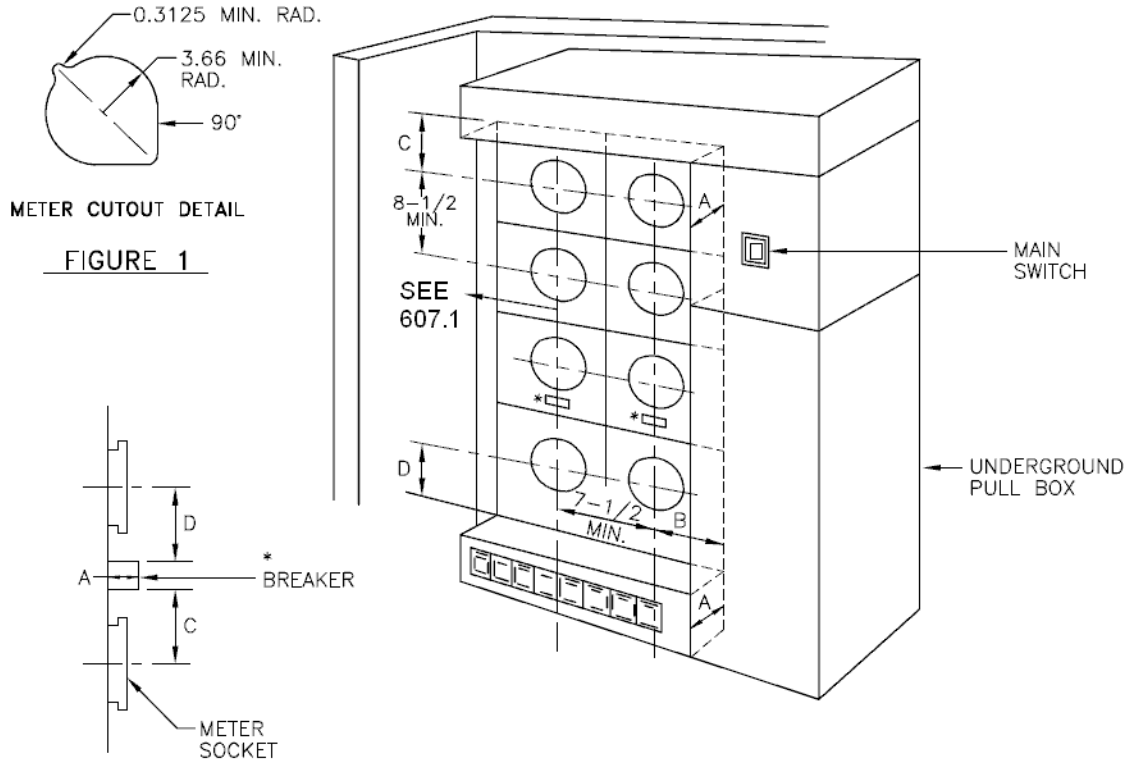

FIGURE 2

* Alternate breaker position below meter socket
See side view detail for clearance dimension

DIMENSIONS - INCHES			
"A" (PROTRUSIONS)	"B" MIN.	"C" MIN.	"D" MIN.
0 (No protrusion)	3-3/4"	4"	4-3/4"
Greater than 0" to 1-1/8"	4-1/4"	4"	4-3/4"
Greater than 1-1/8" to 2"	4-1/4"	4-1/4"	6-1/4"
Greater than 2" to 4"	6-1/4"	4-1/4"	8"
Greater than 4" to 11" max.	6-1/4"	10"	8"

ALL DIMENSIONS SHOWN ARE IN INCHES

SECTION 600 - SERVICE EQUIPMENT SPECIFICATIONS

608 Combination Disconnect Device and Terminating Enclosure

- 608.1 The terminating compartment of the enclosure shall meet the requirements of Section 609, including enclosure dimensions, terminating facilities and facility clearances, and construction details.
- 608.2 A vertical clearance of three (3) inches minimum shall be maintained between the centerline of the top bolts of the terminating facilities to any obstruction.
- 608.3 The grounding electrode conductor may be installed in a fully enclosed, factory installed wireway located in either back corner of the pull box. The raceway shall not impede the Utility's required working space or reduce any specified clearances.
- 608.4 A full width and depth insulated rigid barrier shall be provided to **separate** the termination and main disconnect device compartments.
- 608.5 Termination enclosure covers shall be:
- a) Independent of other equipment and removable without disturbing adjacent panels.
 - b) Sealable or lockable, and provided with two lifting handles, and limited to a maximum of nine (9) square feet in area.
- 608.6 The main disconnect cover shall be sealable or lockable; the fuse access doors shall not be sealable.
- 608.7 The main disconnect cover and the termination enclosure cover shall meet the sealing and locking requirements of Section 305.
- 608.8 Terminating facilities for service conductors shall meet the requirements of Section 627.
- 608.9 A combination disconnect device and terminating enclosure shall only be used on a service with seven (7) or more meter socket positions. This device and enclosure **shall not** be used where there are six (6) or fewer meter socket positions.
- 608.10 The maximum rating for a combination disconnect device and terminating enclosure used in the Utility's service area shall be 1,200 amps. Refer to Section 303 for service ampacity rating details.
- 608.11 The preferred mounting height of a combination disconnect device and terminating enclosure is determined in most cases by the type and style of metering equipment it serves, especially where the equipment is configured with cross bus facilities related to modular metering.
- 608.12 The maximum mounting height for a combination disconnect device and terminating enclosure is ninety (90) inches. Mounting height is measured from the top of the combination disconnect device and terminating enclosure to the finished grade or standing surface immediately in front of the combination disconnect device and terminating enclosure.
- 608.13 No combination disconnect device and terminating enclosure shall be installed with the floor or bottom of the enclosure less than twelve (12) inches above the finished grade or standing surface immediately in front of the enclosure.
- 608.14 Main service disconnects installed on the source side (line-side, ahead of the meter sockets) of a multiple metering installation, whether residential application or commercial application, shall have factory designed and installed sealing and/or locking provisions to seal or lock all areas of the enclosure except for access for fuse replacement or switch operation.

SECTION 600 - SERVICE EQUIPMENT SPECIFICATIONS

608 Combination Disconnect Device and Terminating Enclosure

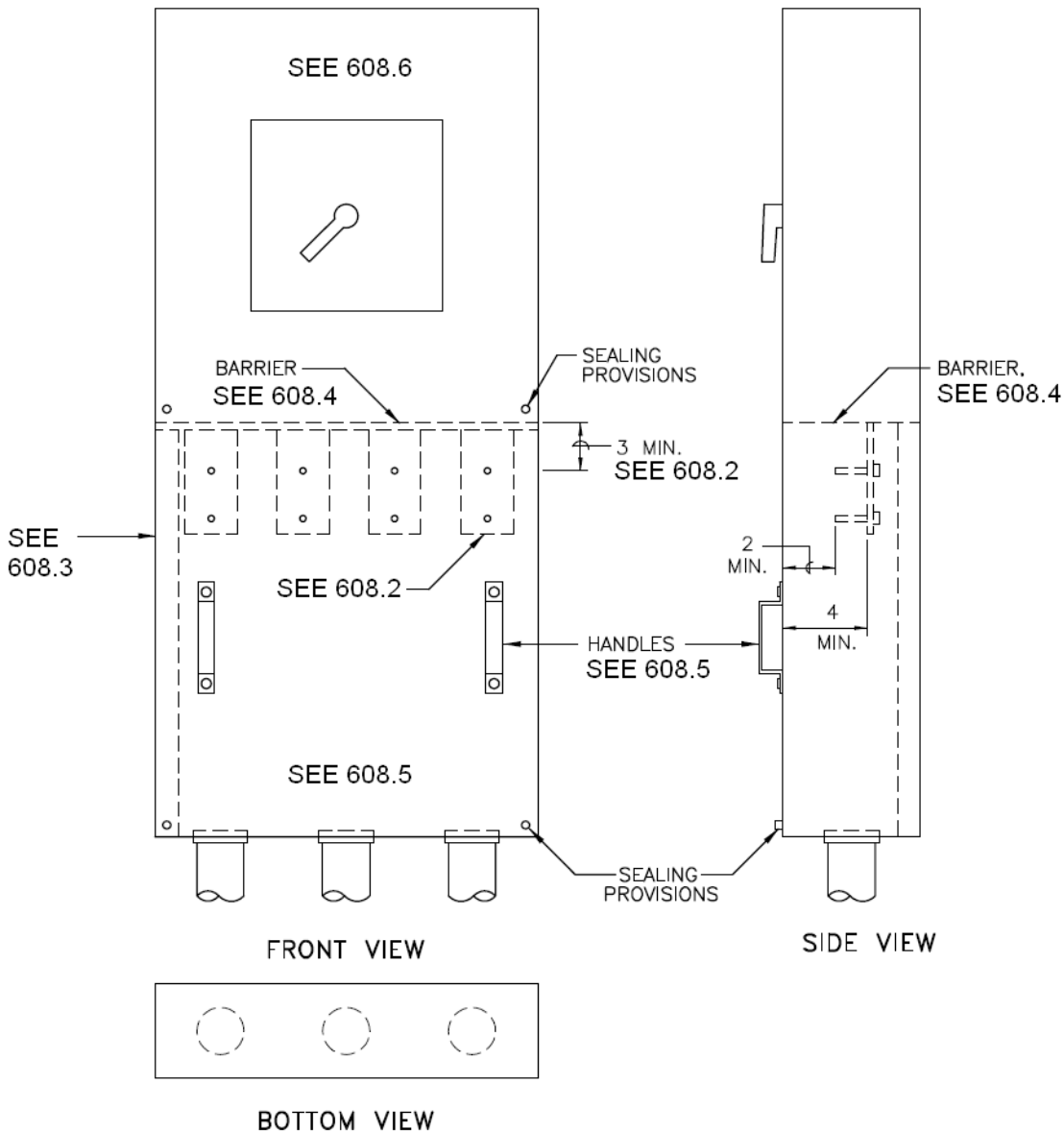

ALL DIMENSIONS SHOWN ARE IN INCHES

608.15 Except where otherwise specified in this book, no sealing and/or locking provisions for securing unmetered conductors or bus and no locking provisions for securing meter disconnects or main service disconnects may be placed behind any door or panel or concealed from view in any manner.

608.16 This service equipment specification is similar to EUSERC Drawing 315.

SECTION 600 - SERVICE EQUIPMENT SPECIFICATIONS

609 Wall-Mounted Pull Box with Terminating Facilities

- 609.1 Terminating facilities for service supply conductors shall be two (2) ½-inch steel bolts as shown. One (1) set of bolts shall be provided for terminations rated up to 400 amperes, two (2) sets of bolts for terminations rated from 401 to 800 amperes and three (3) sets of bolts for terminations rated from 801 to 1,200 amperes.
- 609.2 The terminating facilities of wall-mounted pull boxes shall meet the requirements of Section 627.
- 609.3 Terminating facilities shall be secured to prevent turning or bus misalignment when the cables are installed.
- 609.4 Pull box covers shall be removable, sealable or lockable, provided with two (2) lifting handles, and limited to a maximum size of nine (9) square feet in area.
- 609.5 Wall-mounted pull boxes with terminating facilities shall meet the sealing and locking requirements of Section 305.
- 609.6 The minimum pull box access opening ("W") is measured between the left side and right side return flanges.
- 609.7 The minimum distance for service conductor termination height ("X") is defined as the distance from the lowest bolt on the termination facility to the bottom of the termination enclosure.
- 609.8 Customer system grounding connections may be made inside a wall-mounted pull box with terminating facilities as long as such connections do not interfere with termination of the Utility's (line-side) service conductors or reduce specified clearances.
- 609.9 The maximum rating for wall-mounted pull boxes with terminating facilities used in the Utility's service area shall be 1,200 amps. Refer to Section 303 for service ampacity rating details.
- 609.10 The preferred mounting height of a wall-mounted pull box with terminating facilities in most cases is determined by the type and style of metering equipment it serves, especially where the pull box is configured with cross bus facilities related to modular metering.
- 609.11 The maximum mounting height for a wall-mounted pull box with terminating facilities is ninety (90) inches. Mounting height is measured from the top of the wall-mounted pull box to the finished grade or standing surface immediately in front of the wall-mounted pull box.
- 609.12 No wall-mounted pull box with terminating facilities shall be installed with the floor or bottom of the enclosure less than twelve (12) inches above the finished grade or standing surface immediately in front of the enclosure.
- 609.13 This service equipment specification is similar to EUSERC Drawing 343.

SECTION 600 - SERVICE EQUIPMENT SPECIFICATIONS

609 Wall-Mounted Pull Box with Terminating Facilities

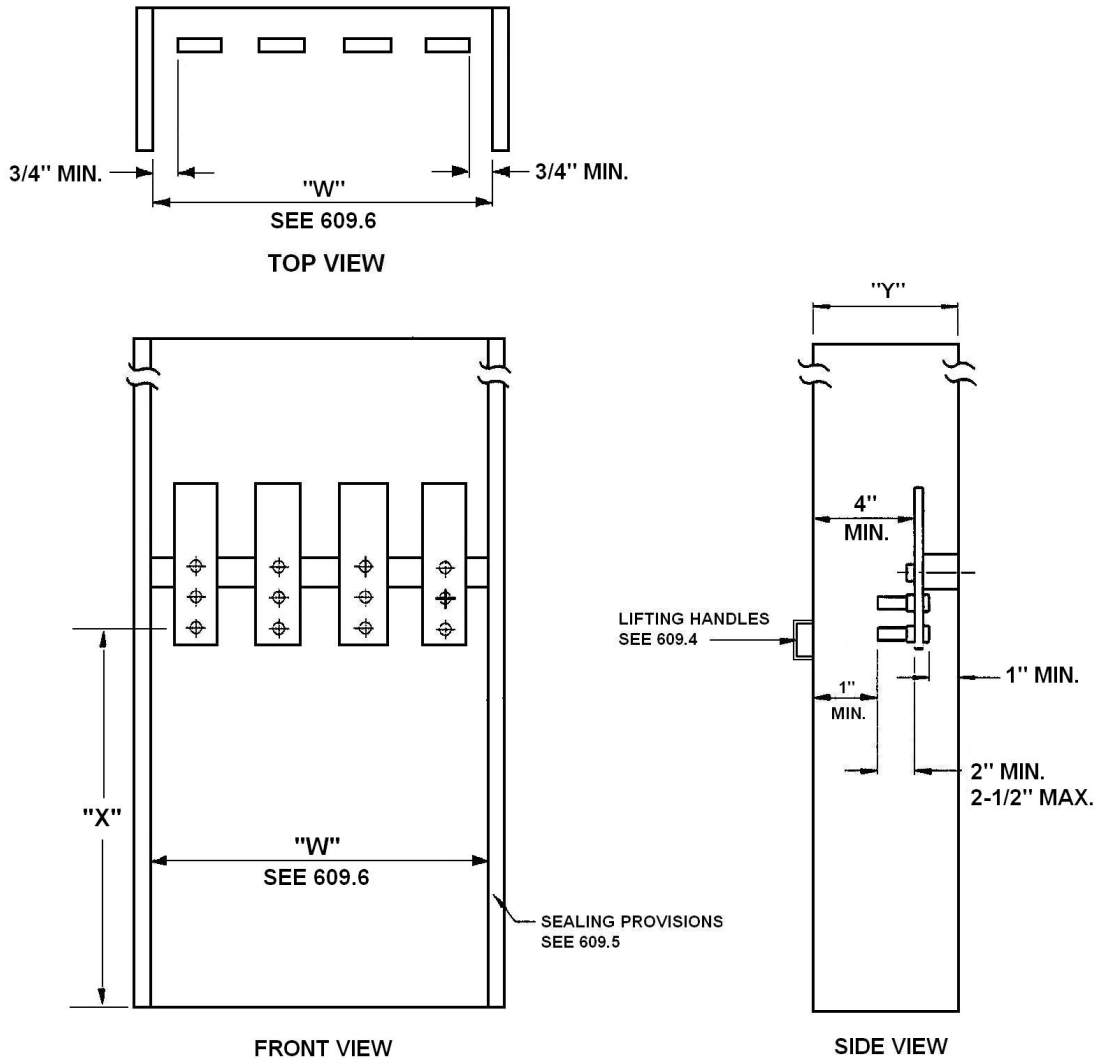

TABLE 1 (MINIMUM PULL BOX DIMENSIONS)

SERVICE AMPACITY	"W" (SEE 609.6)		"Y"	"X"
	3-WIRE	4-WIRE		
0 - 200	10-1/2"	14"	6"	11"
201 - 400	10-1/2"	14"	6"	22"
401 - 800	16-1/2"	22"	11"	26"
801 - 1,200	22-1/2"	30"	11"	26"

ALL DIMENSIONS SHOWN ARE IN INCHES

SECTION 600 - SERVICE EQUIPMENT SPECIFICATIONS

610 Single-Phase CT Mounting Base

- 610.1 Insulated supports shall be rated for the line voltage and shall have sufficient mechanical strength for the application.
- 610.2 The CT mounting base shall be designed to accept bar type CTs meeting the requirements of ANSI C12.11.
- 610.3 Two (2) 1/2-inch steel bolts shall be provided for each cable terminating position and each CT mounting position. The bolts shall extend from two (2) inches to two-and-one-half (2-1/2) inches from the mounting surface and be spaced on one-and-three-quarter (1-3/4) inch vertical centers.
- 610.4 Each terminating bolt and each CT mounting bolt shall be furnished with a spring washer and a nut. The spring washer may be either a cone-type (Belleville) or a split-ring washer and a flat washer. All parts shall be plated to prevent corrosion.
- 610.5 Termination bolts and CT mounting bolts must be secured in place. "Secured in Place" shall mean that the stud will not turn, back out, or loosen in any manner when tightening or loosening the terminal nuts (including cross threaded situations).
- 610.6 CT mounting bases shall have a 50,000 AIC rating.
- 610.7 CT mounting bases used in single-phase service applications shall have mounting provisions for two (2) CTs. Three-phase CT mounting bases (three CT mounting positions) shall not be used in single-phase service applications.
- 610.8 Hardware (Belleville cone type, split ring washers and/or flat washers) for attaching the bolt-type pads or bus stubs (for conductor termination and CT mounting) to the insulated supports of the CT mounting base shall be of a diameter sufficient to allow CT bus bars to lay flat and make full contact with the bolt-type pads or bus stubs.
- 610.9 Wire connectors used in conjunction with CT mounting bases on CT rated services rated from 226 amps to 800 amps shall use 2-hole pressure connectors (lugs), either compression type or set-screw type. The wire connector shall lay flat on the terminating facility on which it is mounted. The connector **shall not** be altered or modified in any way. It is recommended that wire connectors used on CT mounting bases have a main body width of two-and-one-eighth (2-1/8) inches or less.
- 610.10 The 2-hole pressure connectors (lugs), either compression type or set-screw type, used to terminate line-side and/or load-side conductors on CT mounting bases rated up to 800 amps, should not diminish the phase-to-phase or the phase-to-ground clearance. Where clearances are diminished, a minimum clearance of one-and-one-half (1-1/2) inches shall be maintained on phase-to-phase clearances and phase-to-ground clearances.
- 610.11 Wire connectors with a single mounting hole **shall not** be used on CT mounting bases rated up to 800 amps. One-hole pressure connectors (lugs), either compression type or set-screw type, are prohibited. This requirement applies to both the Utility's (line-side) terminations and customer's (load-side) terminations.
- 610.12 Pressure connectors (lugs), either compression type or set-screw type, **shall not** be altered or modified in any way. This requirement applies to both the Utility's (line-side) terminations and customer's (load-side) terminations.

(Continued on page 158)

SECTION 600 - SERVICE EQUIPMENT SPECIFICATIONS

610 Single-Phase CT Mounting Base

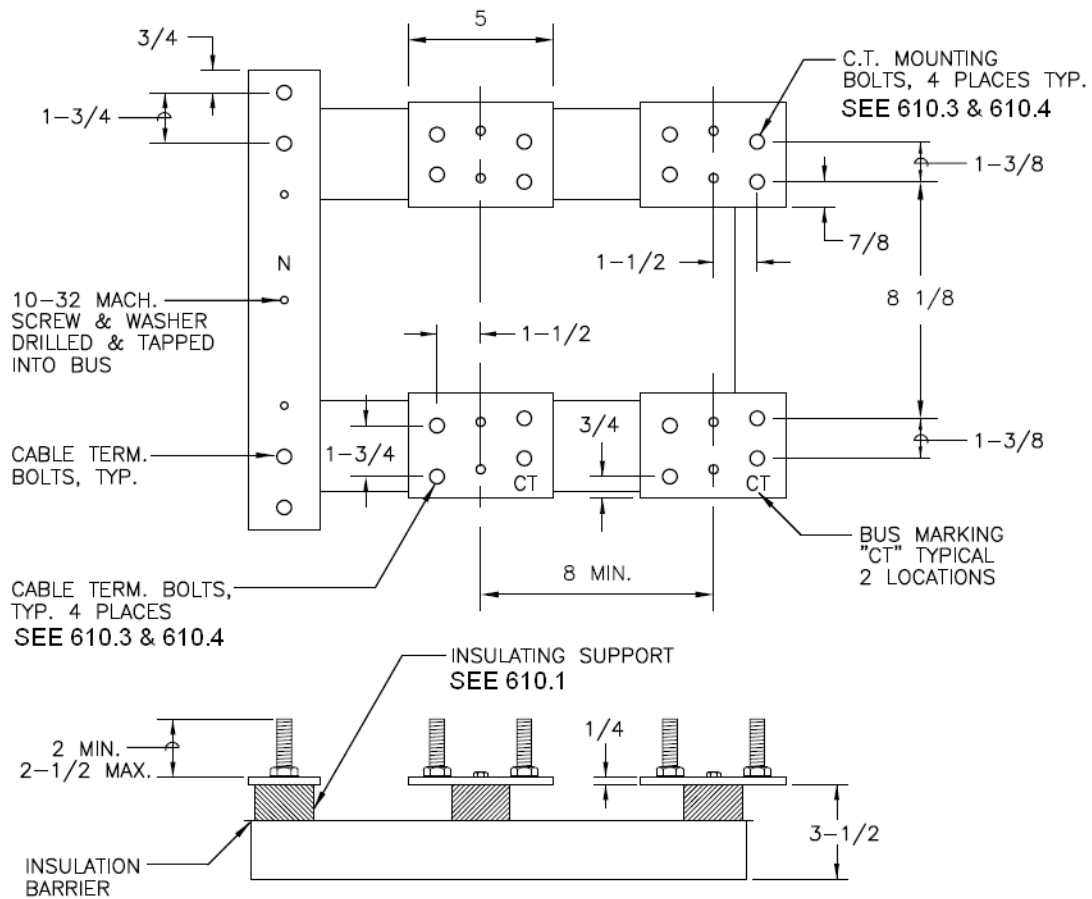

ALL DIMENSIONS SHOWN ARE IN INCHES

SECTION 600 - SERVICE EQUIPMENT SPECIFICATIONS

610 Single-Phase CT Mounting Base

- 610.13 A maximum of two (2) conductors per phase shall be allowed on any one (1) cable terminating position when using CT mounting bases with 1/2-inch terminating studs on 1-3/4 inch centers. This two-conductor per phase maximum limit applies to both the Utility's (line-side) and customer's (load-side) wire terminations.
- 610.14 Service installations that require three (3) or more conductors per phase shall use a CT mounting base with integral mechanical lugs for both the Utility's (line-side) and customer's (load-side) wire terminations.
- 610.15 Where CT mounting bases with integral mechanical lugs are used, an 800 amp rated unit is required regardless of the rating of the meter disconnect. An 800 amp rated CT mounting base with integral mechanical lugs provides three (3) conductor landing positions for each of the two (2) phases and three (3) conductor landing positions for the neutral conductors. A 400 amp rated CT mounting base with integral mechanical lugs provides three (3) conductor landing positions for each phase, but only one (1) landing position for the neutral conductors. Therefore, 400 amp rated CT mounting bases with integral mechanical lugs **are prohibited** from use on the Utility's system.
- 610.16 Customer designers and installers must contact the Utility's Engineering Division to verify the number of conductors per phase and the conductor size planned by the Utility for a particular service installation.
- 610.17 This service equipment specification is similar to EUSERC Drawing 328A.

SECTION 600 - SERVICE EQUIPMENT SPECIFICATIONS

RESERVED

SECTION 600 - SERVICE EQUIPMENT SPECIFICATIONS

611 Single-Phase CT Mounting Base with Integral Lugs

- 611.1 Insulated supports shall be rated for the line voltage and shall have sufficient mechanical strength for the application.
- 611.2 The CT mounting base shall be designed to accept bar type CTs meeting the requirements of ANSI C12.11.
- 611.3 Two (2) 1/2-inch steel bolts shall be provided for each CT mounting position. The bolts shall extend from two (2) inches to two-and-one-half (2-1/2) inches from the mounting surface and be spaced on one-and-three-quarter (1-3/4) inch vertical centers.
- 611.4 Each CT mounting bolt shall be furnished with a spring washer and a nut. The spring washer may be either a cone-type (Belleville) or a split-ring washer and a flat washer. All parts shall be plated to prevent corrosion.
- 611.5 CT mounting bolts must be secured in place. "Secured in Place" shall mean that the stud will not turn, back out, or loosen in any manner when tightening or loosening the terminal nuts (including cross threaded situations).
- 611.6 CT mounting bases shall have a 50,000 AIC rating.
- 611.7 CT mounting bases used in single-phase service applications shall have mounting provisions for two (2) CTs. Three-phase CT mounting bases (three CT mounting positions) shall not be used in single-phase service applications.
- 611.8 Hardware (Belleville cone type, split ring washers and/or flat washers) for attaching the bolt-type pads or bus stubs (for CT mounting) to the insulated supports of the CT mounting base shall be of a diameter sufficient to allow CT bus bars to lay flat and make full contact with the bolt-type pads or bus stubs.
- 611.9 Terminations for service conductors shall have three (3) conductor positions per phase and three (3) conductor positions for the neutral.
- 611.10 The terminations shall be aluminum-bodied mechanical lugs also referred to as integral mechanical lugs.
- 611.11 Each conductor position shall be rated to accept two (2) conductors. The integral mechanical lugs shall have a conductor range from No. 4 AWG through 600 KCMIL for one (1) conductor per position applications and a conductor range from No. 1 AWG through 250 KCMIL for two (2) conductors per position applications.
- 611.12 Service installations that require three (3) or more conductors per phase shall use a CT mounting base with integral mechanical lugs for both the Utility's (line-side) and customer's (load-side) wire terminations.
- 611.13 Where CT mounting bases with integral mechanical lugs are used, an 800 amp rated unit is required regardless of the rating of the meter disconnect. An 800 amp rated CT mounting base with integral mechanical lugs provides three (3) conductor landing positions for each of the two (2) phases and three (3) conductor landing positions for the neutral conductors. A 400 amp rated CT mounting base with integral mechanical lugs provides three (3) conductor landing positions for each phase, but only one (1) landing position for the neutral conductors. Therefore, 400 amp rated CT mounting bases with integral mechanical lugs **are prohibited** from use on the Utility's system.

SECTION 600 - SERVICE EQUIPMENT SPECIFICATIONS

611 Single-Phase CT Mounting Base with Integral Lugs

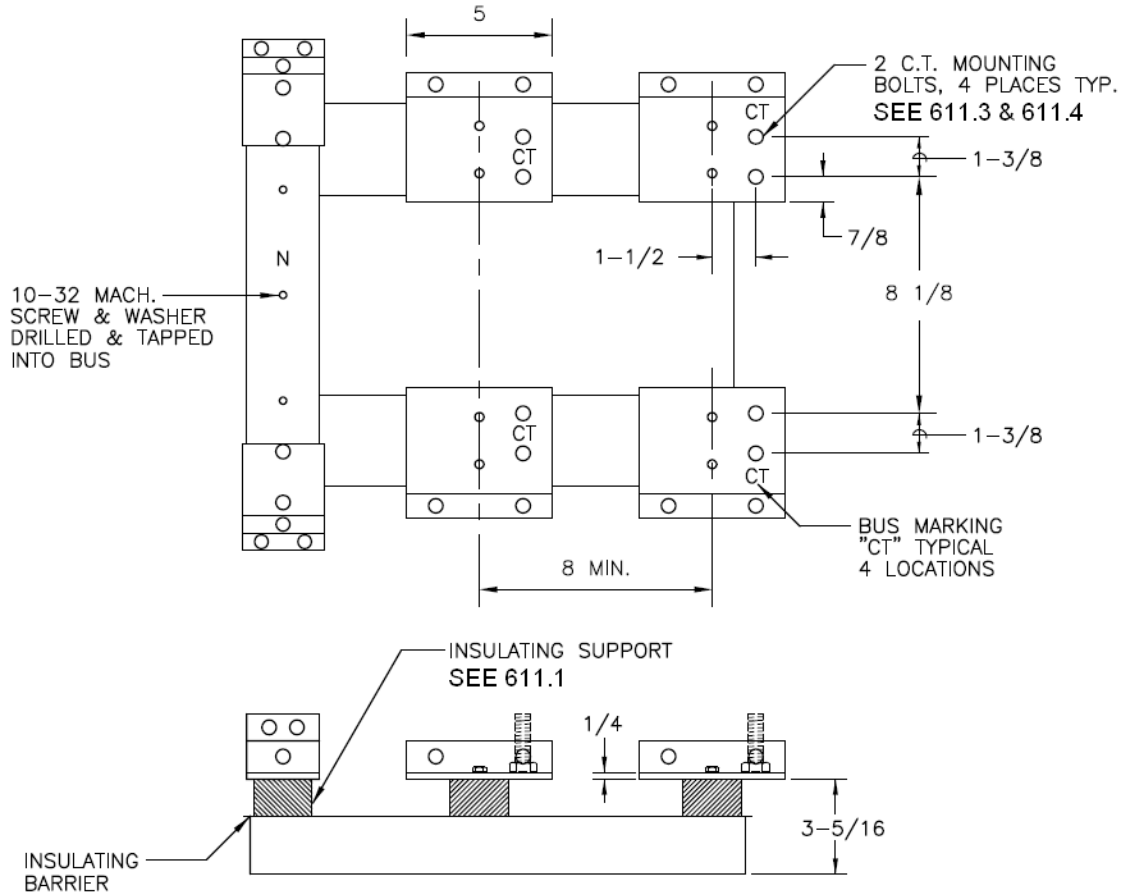

ALL DIMENSIONS SHOWN ARE IN INCHES

611.14 Customer designers and installers must contact the Utility's Engineering Division to verify the number of conductors per phase and the conductor size planned by the Utility for a particular service installation.

611.15 This service equipment specification is similar to EUSERC Drawing 328B.

SECTION 600 - SERVICE EQUIPMENT SPECIFICATIONS

612 Three-Phase CT Mounting Base

- 612.1 Insulated supports shall be rated for the line voltage and shall have sufficient mechanical strength for the application.
- 612.2 The CT mounting base shall be designed to accept bar type CTs meeting the requirements of ANSI C12.11.
- 612.3 Two (2) 1/2-inch steel bolts shall be provided for each cable terminating position and each CT mounting position. The bolts shall extend from two (2) inches to two-and-one-half (2-1/2) inches from the mounting surface and be spaced on one-and-three-quarter (1-3/4) inch vertical centers.
- 612.4 Each terminating bolt and each CT mounting bolt shall be furnished with a spring washer and a nut. The spring washer may be either a cone-type (Belleville) or a split-ring washer and a flat washer. All parts shall be plated to prevent corrosion.
- 612.5 Termination bolts and CT mounting bolts must be secured in place. "Secured in Place" shall mean that the stud will not turn, back out, or loosen in any manner when tightening or loosening the terminal nuts (including cross threaded situations).
- 612.6 CT mounting bases shall have a 50,000 AIC rating.
- 612.7 CT mounting bases used in three-phase service applications shall have mounting provisions for three (3) CTs.
- 612.8 Hardware (Belleville cone type, split ring washers and/or flat washers) for attaching the bolt-type pads or bus stubs (for conductor termination and CT mounting) to the insulated supports of the CT mounting base shall be of a diameter sufficient to allow CT bus bars to lay flat and make full contact with the bolt-type pads or bus stubs.
- 612.9 Wire connectors used in conjunction with CT mounting bases on CT rated services rated from 226 amps to 800 amps shall use 2-hole pressure connectors (lugs), either compression type or set-screw type. The wire connector shall lay flat on the terminating facility on which it is mounted. The connector **shall not** be altered or modified in any way. It is recommended that wire connectors used on CT mounting bases have a main body width of two-and-one-eighth (2-1/8) inches or less.
- 612.10 The 2-hole pressure connectors (lugs), either compression type or set-screw type, used to terminate line-side and/or load-side conductors on CT mounting bases rated up to 800 amps, should not diminish the phase-to-phase clearance or the phase-to-ground clearance. Where clearances are diminished, a minimum clearance of one-and-one-half (1-1/2) inches shall be maintained on phase-to-phase clearances and on phase-to-ground clearances.
- 612.11 Wire connectors with a single mounting hole shall not be used on CT mounting bases rated up to 800 amps. One-hole pressure connectors (lugs), either compression type or set-screw type, **are prohibited**. This requirement applies to both the Utility's (line-side) terminations and customer's (load-side) terminations.
- 612.12 Pressure connectors (lugs), either compression type or set-screw type, shall not be altered or modified in any way. This requirement applies to both the Utility's (line-side) terminations and customer's (load-side) terminations.

(Continued on page 164)

SECTION 600 - SERVICE EQUIPMENT SPECIFICATIONS

612 Three-Phase CT Mounting Base

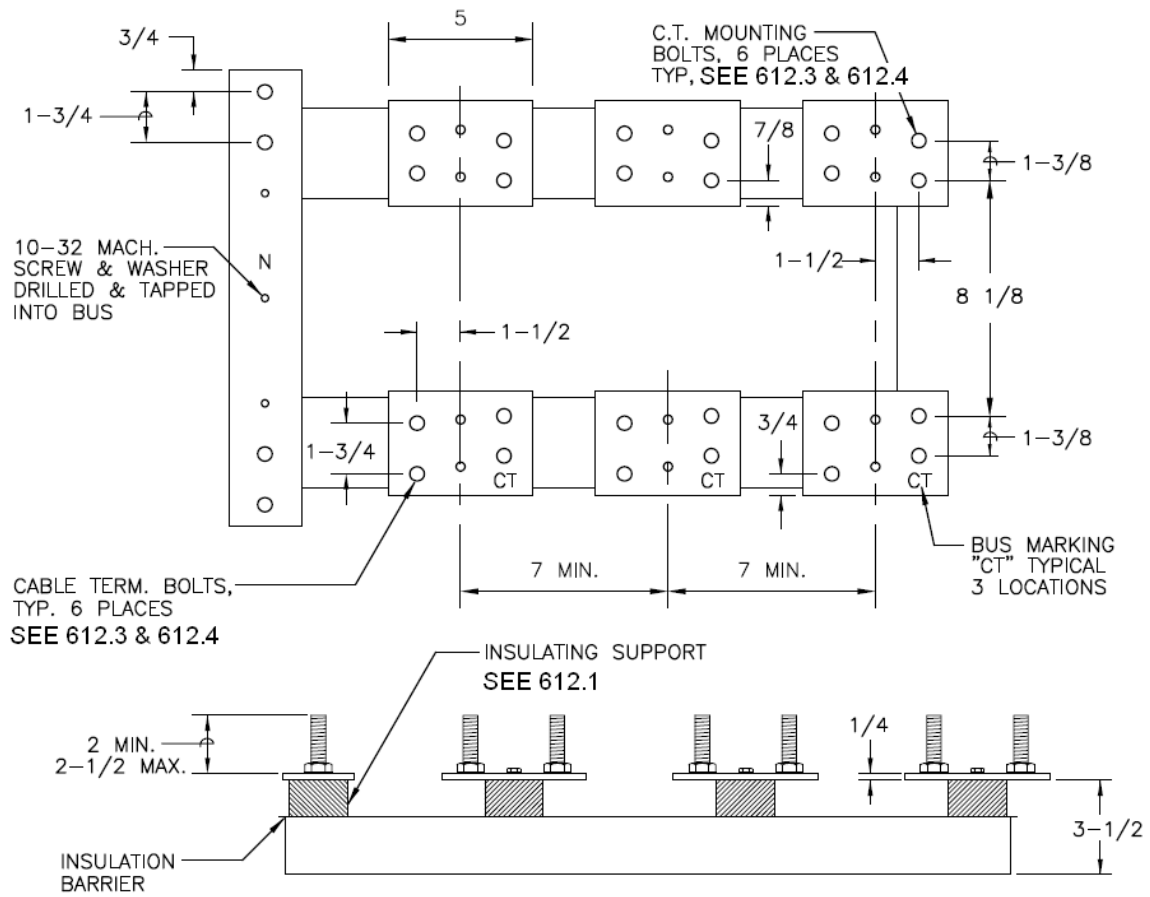

ALL DIMENSIONS SHOWN ARE IN INCHES

SECTION 600 - SERVICE EQUIPMENT SPECIFICATIONS

612 Three-Phase CT Mounting Base

- 612.13 A maximum of two (2) conductors per phase shall be allowed on any one (1) cable terminating position when using CT mounting bases with one-half (1/2)-inch terminating studs on one-and-three-quarter (1-3/4)-inch centers. This two-conductor per phase maximum limit applies to both the Utility's (line-side) and customer's (load-side) wire terminations.
- 612.14 Service installations that require three (3) or more conductors per phase shall use a CT mounting base with integral mechanical lugs for both the Utility's (line-side) and customer's (load-side) wire terminations.
- 612.15 Where CT mounting bases with integral mechanical lugs are used, an 800 amp rated unit is required regardless of the rating of the meter disconnect. An 800 amp rated CT mounting base with integral mechanical lugs provides three (3) conductor landing positions for each of the three (3) phases and three (3) conductor landing positions for the neutral conductors. A 400 amp rated CT mounting base with integral mechanical lugs provides three (3) conductor landing positions for each phase, but only one (1) landing position for the neutral conductors. Therefore, 400 amp rated CT mounting bases with integral mechanical lugs **are prohibited** from use on the Utility's system.
- 612.16 Customer designers and installers must contact the Utility's Engineering Division to verify the number of conductors per phase and the conductor size planned by the Utility for a particular service installation.
- 612.17 This service equipment specification is similar to EUSERC Drawing 329A.

SECTION 600 - SERVICE EQUIPMENT SPECIFICATIONS

RESERVED

SECTION 600 - SERVICE EQUIPMENT SPECIFICATIONS

613 Three-Phase CT Mounting Base with Integral Lugs

- 613.1 Insulated supports shall be rated for the line voltage and shall have sufficient mechanical strength for the application.
- 613.2 The CT mounting base shall be designed to accept bar type CTs meeting the requirements of ANSI C12.11.
- 613.3 Two (2) 1/2-inch steel bolts shall be provided for each CT mounting position. The bolts shall extend from two (2) inches to two-and-one-half (2-1/2) inches from the mounting surface and be spaced on one-and-three-quarter (1-3/4) inch vertical centers.
- 613.4 Each CT mounting bolt shall be furnished with a spring washer and a nut. The spring washer may be either a cone-type (Belleville) or a split-ring washer and a flat washer. All parts shall be plated to prevent corrosion.
- 613.5 CT mounting bolts must be secured in place. "Secured in Place" shall mean that the stud will not turn, back out, or loosen in any manner when tightening or loosening the terminal nuts (including cross threaded situations).
- 613.6 CT mounting bases shall have a 50,000 AIC rating.
- 613.7 CT mounting bases used in three-phase service applications shall have mounting provisions for three (3) CTs.
- 613.8 Hardware (Belleville cone type, split ring washers and/or flat washers) for attaching the bolt-type pads or bus stubs (for CT mounting) to the insulated supports of the CT mounting base shall be of a diameter sufficient to allow CT bus bars to lay flat and make full contact with the bolt-type pads or bus stubs.
- 613.9 Terminations for service conductors shall have three (3) conductor positions per phase and three (3) conductor positions for the neutral.
- 613.10 The terminations shall be aluminum-bodied mechanical lugs also referred to as integral mechanical lugs.
- 613.11 Each conductor position shall be rated to accept two (2) conductors. The integral mechanical lugs shall have a conductor range from No. 4 AWG through 600 KCMIL for one (1) conductor per position applications and a conductor range from No. 1 AWG through 250 KCMIL for two (2) conductors per position applications.
- 613.12 CT mounting bases used in three-phase applications shall have mounting provisions for three (3) CTs.
- 613.13 Service installations that require three (3) or more conductors per phase shall use a CT mounting base with integral mechanical lugs for both the Utility's (line-side) and customer's (load-side) wire terminations.
- 613.14 Where CT mounting bases with integral mechanical lugs are used, an 800 amp rated unit is required regardless of the rating of the meter disconnect. An 800 amp rated CT mounting base with integral mechanical lugs provides three (3) conductor landing positions for each of the three (3) phases and three (3) conductor landing positions for the neutral conductors. A 400 amp rated CT mounting base with integral mechanical lugs provides three (3) conductor landing positions for each phase, but only one (1) landing position for the neutral conductors. Therefore, 400 amp rated CT mounting bases with integral mechanical lugs **are prohibited** from use on the Utility's system.

SECTION 600 - SERVICE EQUIPMENT SPECIFICATIONS

613 Three-Phase CT Mounting Base with Integral Lugs

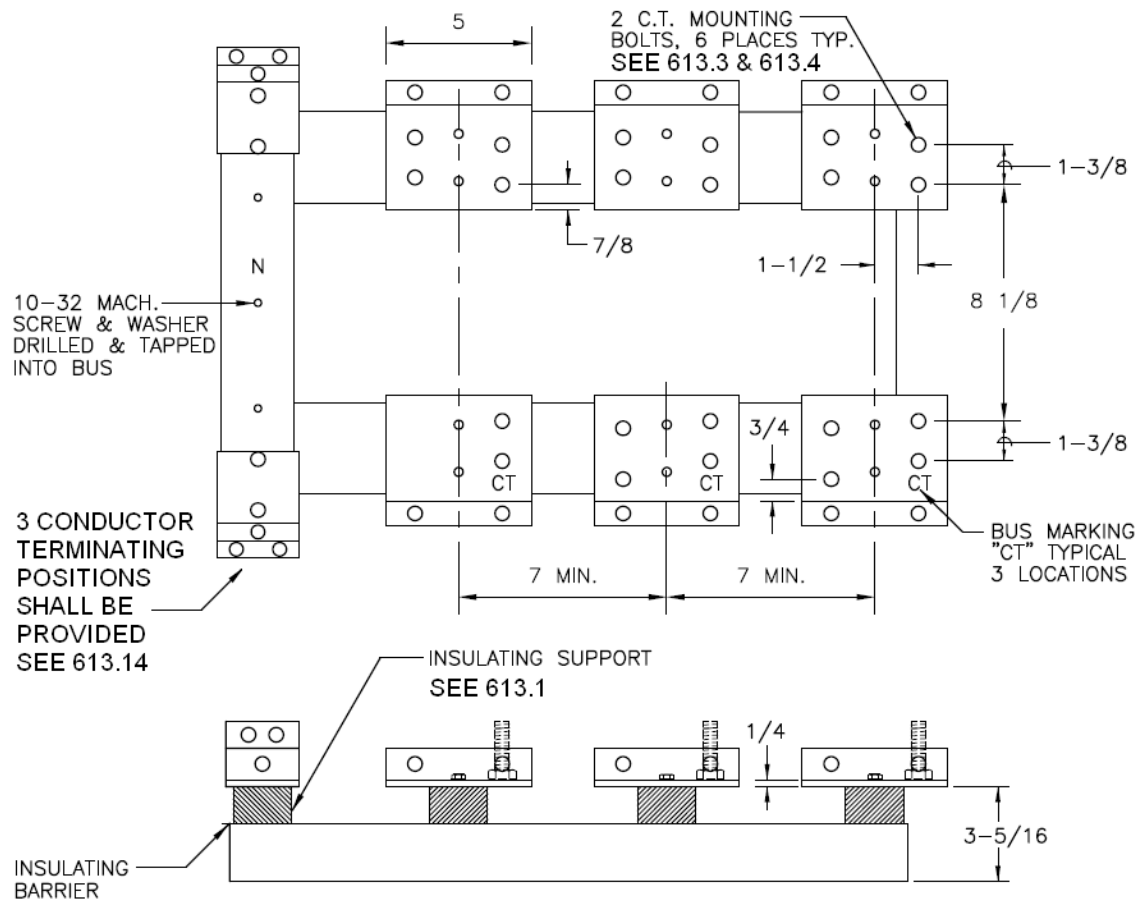

ALL DIMENSIONS SHOWN ARE IN INCHES

613.15 Customer designers and installers must contact the Utility's Engineering Division to verify the number of conductors per phase and the conductor size planned by the Utility for a particular service installation.

613.16 This service equipment specification is similar to EUSERC Drawing 329B.

SECTION 600 - SERVICE EQUIPMENT SPECIFICATIONS

614 CT Cabinet, Wall-Mounted, 201 Amps to 800 Amps

- 614.1 CT cabinets shall be designed to house CTs that meet ANSI C12.11.
- 614.2 CT cabinets shall be UL 414 listed and NEMA TYPE 3R rated.
- 614.3 CT cabinets shall have a hinged front cover for access to the CTs. The hinged front cover requirement applies to wall mounted CT cabinets in both single-phase and three-phase service applications.
- 614.4 CT cabinets with covers fastened by machine screws and/or threaded cover mounting studs **shall not** be used; they are prohibited.
- 614.5 The CT cabinet's hinged front cover shall be lockable and sealable. The cover shall accept a padlock with a minimum shackle diameter of five-sixteenths (5/16) inch. The CT cabinet shall meet the applicable parts of Section 305.
- 614.6 CT cabinets shall have a minimum of four (4) quarter-twenty (1/4-20) mounting studs on the back wall of the enclosure body spaced to accept a CT mounting base.
- 614.7 CT cabinets for use on services rated from 201 amps to 800 amps shall have provisions for the installation of CT mounting bases meeting the requirements of Sections 610, 611, 612, and 613.
- 614.8 **Cabinet Dimensions, Single-Phase, 201 to 400 Amps:** CT cabinets for single-phase services 201 to 400 amps shall have minimum dimensions of thirty-six (36) inches in height, thirty (30) inches in width, and eleven (11) inches in depth.
- 614.9 **Cabinet Dimensions, Single-Phase, 401 to 800 Amps:** CT cabinets for single-phase services 401 to 800 amps shall have minimum dimensions of thirty-six (36) inches in height, thirty-six (36) inches in width, and eleven (11) inches in depth.
- 614.10 **Cabinet Dimensions, Three-Phase, 201 to 600 Amps:** CT cabinets for three-phase services 201 to 600 amps shall have minimum dimensions of forty-eight (48) inches in height, thirty-six (36) inches in width, and eleven (11) inches in depth.
- 614.11 **Cabinet Dimensions, Three-Phase, 601 to 800 Amps:** CT cabinets for three-phase services 601 to 800 amps shall have minimum dimensions of forty-eight (48) inches in height, forty-eight (48) inches in width, and fourteen (14) inches in depth.
- 614.12 On three-phase CT rated services where circumstances require both the conduits for customer's (load-side) conductors and the conduits for the Utility's (line-side) conductors to land on the bottom or floor of the cabinet, the minimum cabinet dimensions shall be forty-eight (48) inches in height, forty-eight (48) inches in width, and fourteen (14) inches in depth.
- 614.13 The customer's (load-side) conductors **shall not** pass over the top of, in front of, or in any way restrict access to the Utility's (line-side) conductors or the CTs. Depending on the circumstances, a larger CT cabinet may be necessary to meet this requirement.
- 614.14 Placement of customer's (load-side) conduits is a critical part of meeting the requirement of Subsection 614.13.
- 614.15 Hinged CT cabinet doors **shall be** properly aligned and adjusted for ease of operation. Doors that require pounding, hammering, and/or prying to remove and or re-install are **not** acceptable. The Utility will not energize CT rated services with wall-mounted CT cabinets until it has been demonstrated that all hinged CT cabinet doors operate in an appropriate manner.

SECTION 600 - SERVICE EQUIPMENT SPECIFICATIONS

614 CT Cabinet, Wall-Mounted, 201 Amps to 800 Amps

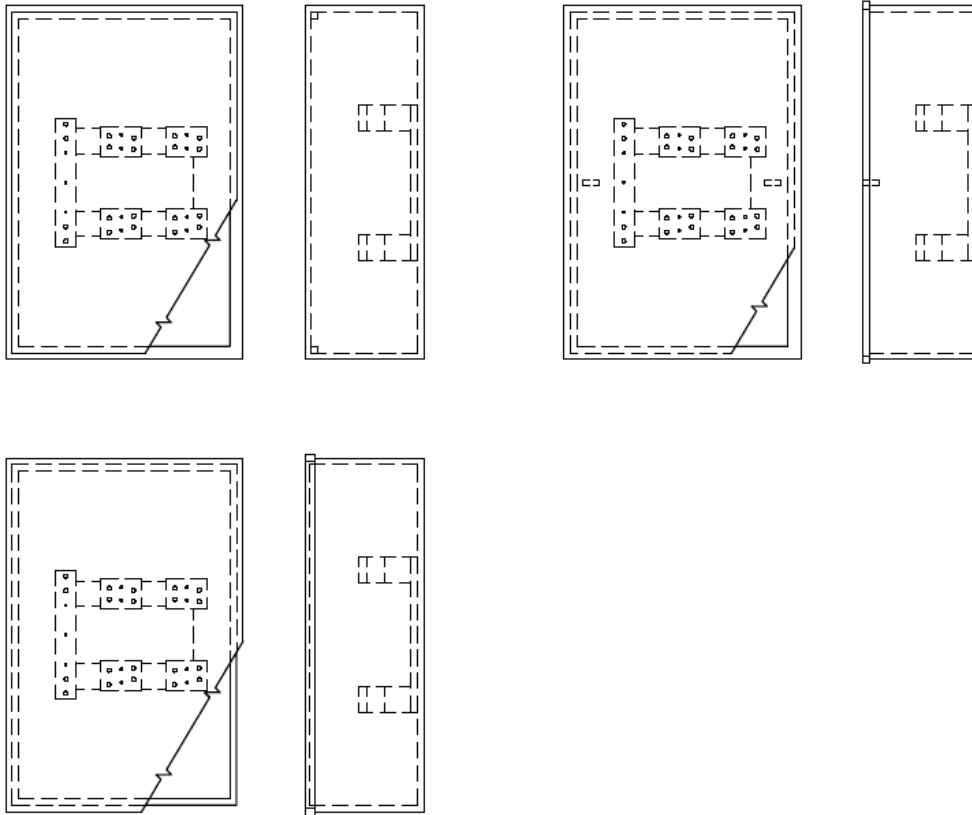

614.16 **The preferred mounting height for wall-mounted CT cabinets on services rated up to 800 amps is seventy (70) inches.** The maximum mounting height for wall-mounted CT cabinets on services rated up to 800 amps is eighty-four (84) inches. The minimum mounting height for wall-mounted CT cabinets on services rated up to 800 amps is sixty-four (64) inches. Mounting height is measured from the top of the CT cabinet to the finished grade or standing surface immediately in front of the CT cabinet.

614.17 No wall-mounted CT cabinet shall be installed with the floor or bottom of the enclosure less than sixteen (16) inches above the finished grade or standing surface immediately in front of the cabinet.

614.18 This service equipment specification is similar to EUSERC Drawing 316.

SECTION 600 - SERVICE EQUIPMENT SPECIFICATIONS

615 CT Cabinet, Wall-Mounted, 801 Amps to 2,500 Amps

- 615.1 CT cabinets shall be designed to house CTs meeting ANSI C12.11
- 615.2 CT cabinets shall be UL 414 listed and NEMA TYPE 3R rated.
- 615.3 CT cabinets shall consist of a main compartment and a side gutter compartment. The two compartments shall be joined together without gaps, open spaces, or other access points into the interior of either compartment.
- 615.4 The wireway between the main compartment and the side gutter compartment shall have rounded edges, a bushed opening, or other similar protection against abrasion of the line-side service conductors.
- 615.5 The wireway between the main compartment and the side gutter compartment shall be of sufficient size to maintain an appropriate wire bending radius for line-side service conductors. The size of the wireway opening between the main compartment and the side gutter compartment shall be no less than sixteen (16) inches in height and ten (10) inches in width on CT cabinets rated up to 1,200 amps and no less than nineteen (19) inches in height and no less than ten (10) inches in width on CT cabinets rated from 1,201 amps to 2,500 amps.
- 615.6 The CT cabinet may be configured with a left-hand side gutter compartment or a right-hand side gutter compartment for entry of the Utility's (line-side) service conductors.
- 615.7 The CT cabinet may be configured with **both** a left-hand side gutter compartment and a right-hand side gutter compartment. One side gutter would be for entry of line-side service conductors and the other side gutter would be for the exit of load-side conductors.
- 615.8 The CT cabinet shall have CT mounting provisions, line-side wire terminating facilities, and load-side wire terminating facilities.
- 615.9 The CT mounting provisions shall include CT supports and removable bus links meeting the requirements of Section 623 or the Utility approved equivalent mounting provisions.
- 615.10 The CT mounting provisions shall orient the body of the window-type CTs in a horizontal manner with the openings of the CT facing up and down and with the removable bus links oriented in a vertical manner. This method of CT mounting will place edges of the CT body side-to-side and will provide for the Utility's (line-side) conductors to land on the top of the CTs and the customer's (load-side) conductors to land on the bottom of the CTs.
- 615.11 The CT cabinet shall have wire terminating facilities meeting the requirements of Section 627 or the Utility approved equivalent terminating facilities.
- 615.12 Equivalent Terminating Facilities, General: In most cases, approved equivalent terminating facilities shall consist of manufacturer provided set screw-type pressure connectors (lugs), rated to accept copper or aluminum conductors, with a minimum wire size range from No. 2 AWG to 600 kcmil. If the lugs provided by the manufacturer have a single mounting hole, the lug body shall include an integral alignment tine or anti-camming ledge. In all other cases, the lugs provided by the manufacturer shall have two (2) mounting holes designed for a one-half (1/2)-inch stud size, spaced on one-and-three-quarter (1-3/4)-inch centers, and include all mounting hardware.

(Continued on page 172)

SECTION 600 - SERVICE EQUIPMENT SPECIFICATIONS

615 CT Cabinet, Wall-Mounted, 801 Amps to 2,500 Amps

Diagram shown without side gutter.

Diagram shown without CTs.

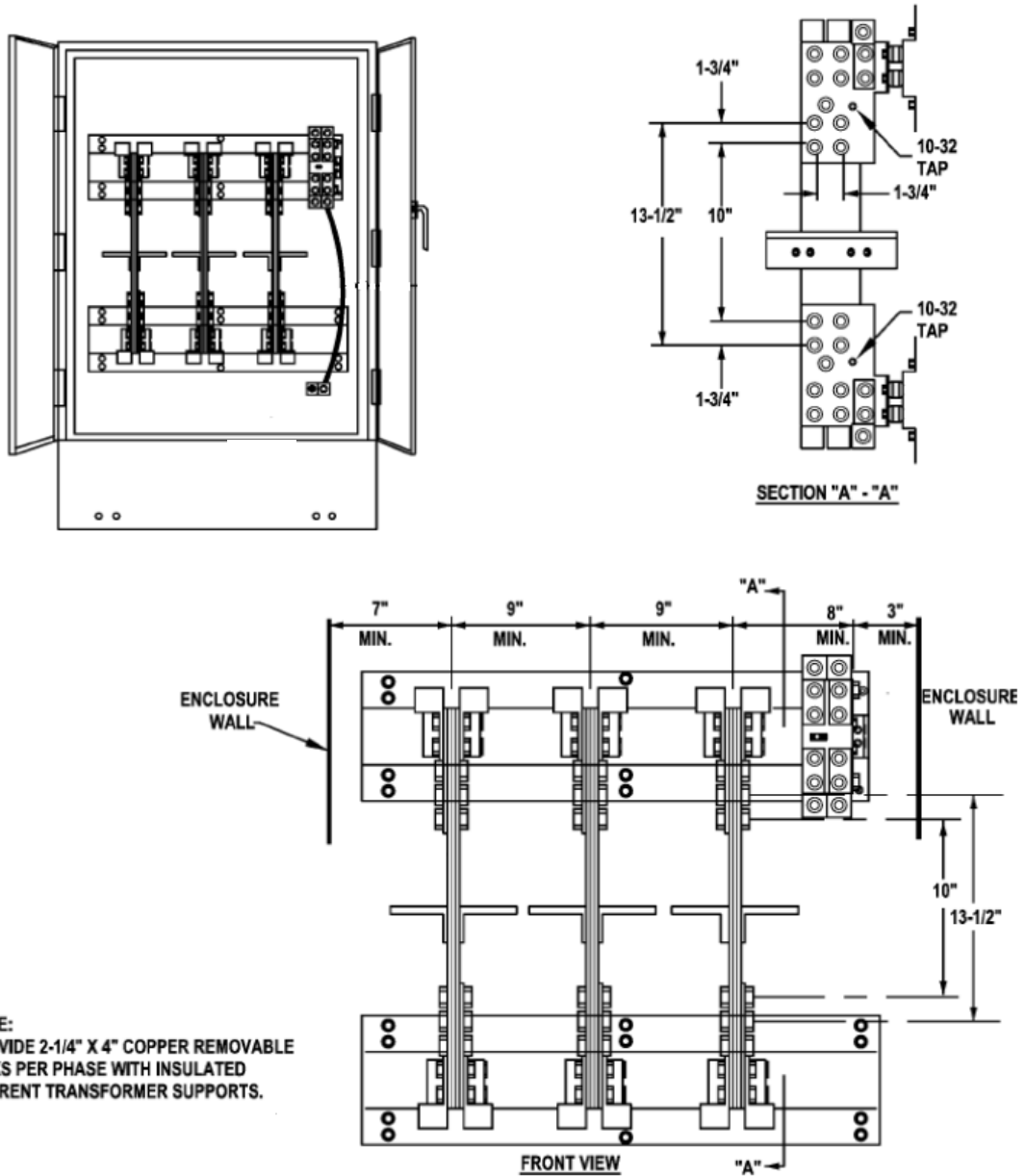

ALL DIMENSIONS SHOWN ARE IN INCHES

SECTION 600 - SERVICE EQUIPMENT SPECIFICATIONS

615 CT Cabinet, Wall-Mounted, 801 Amps to 2,500 Amps

- 615.13 Equivalent Terminating Facilities, Number of Lugs: The manufacturer shall provide approved lugs for each phase position and the neutral position in quantities specified as follows:
- Three (3) lugs for CT cabinets rated from 801 amps to 1,200 amps,
 - Four (4) lugs for CT cabinets rated from 1,201 amps to 1,600 amps,
 - Five (5) lugs for CT cabinets rated from 1,601 amps to 2,000 amps,
 - Seven (7) lugs for CT cabinets rated from 2,001 amps to 2,500 amps.
- 615.14 **Cabinet Dimensions, Three-Phase, 801 to 1,200 amps:** CT cabinets for three-phase services from 801 amps to 1,200 amps shall have minimum dimensions as follows:
- Main compartment shall be a minimum of sixty (60) inches in height, thirty-six (36) inches in width, and fourteen (14) inches in depth.
 - Side gutter compartment shall be a minimum of fifty (50) inches in height, fourteen (14) inches in width, and fourteen (14) inches in depth.
- 615.15 **Cabinet Dimensions, Three-Phase, 1,201 to 1,600 amps:** CT cabinets for three-phase services from 1,201 amps to 1,600 amps shall have minimum dimensions as follows:
- Main compartment shall be a minimum of sixty (60) inches in height, thirty-six (36) inches in width, and fourteen (14) inches in depth.
 - Side gutter compartment shall be a minimum of fifty (50) inches in height, twenty-four (24) inches in width, and fourteen (14) inches in depth.
- 615.16 **Cabinet Dimensions, Three-Phase, 1,601 to 2,500 amps:** CT cabinets for three-phase services from 1,601 amps to 2,500 amps shall have minimum dimensions as follows:
- Main compartment shall be a minimum of sixty-four (64) inches in height, forty (40) inches in width, and fourteen (14) inches in depth.
 - Side gutter compartment shall be a minimum of fifty (50) inches in height, twenty-four (24) inches in width, and fourteen (14) inches in depth.
- 615.17 The CT cabinet main compartment shall be the hinged cover type. Screw cover type cabinets **are prohibited**.
- 615.18 The side gutter compartment(s) of the CT cabinet may be the hinged cover type or the screw cover type.
- 615.19 The hinged cover of the CT cabinet's main compartment shall be lockable, accepting a padlock with a shackle diameter of five-sixteenths (5/16) inch, and shall meet the requirements of Section 305.
- 615.20 The customer's (load-side) conductors **shall not** pass over the top of, in front of, or in any way restrict access to the Utility's (line-side) conductors or the CTs. Depending on circumstances, a larger CT cabinet or side gutter compartment may be necessary to meet this requirement.

SECTION 600 - SERVICE EQUIPMENT SPECIFICATIONS

615 CT Cabinet, Wall-Mounted, 801 Amps to 2,500 Amps

- 615.21 Placement of customer's (load-side) conduits is a critical aspect of meeting the requirements of Subsection 615.20.
- 615.22 The conduit connecting the CT rated meter socket enclosure and the CT cabinet shall provide a minimum of three (3) inches of clear and unobstructed wiring space on the CT cabinet end. Possible obstructions such as the CT mounting base support brackets or customer's (load-side) conductors shall be positioned such that the three (3)-inch free wiring space dimension is maintained.
- 615.23 Hinged main compartment doors side gutter compartment panels, whether screw cover type or hinged door type, **shall be** properly aligned and adjusted for ease of operation. Doors and panels that require pounding, hammering, and/or prying to remove and or re-install **are not** acceptable. The Utility will not energize CT rated services with wall-mounted CT cabinets until it has been demonstrated that all hinged main compartment doors and all side gutter compartment panel covers operate in an appropriate manner.
- 615.24 **The preferred mounting height for wall-mounted CT cabinets on services rated up to 1,600 amps is eighty (80) inches.** The maximum mounting height for wall-mounted CT cabinets on services rated up to 1,600 amps is eighty-six (86) inches. The minimum mounting height for wall-mounted CT cabinets on services rated up to 1,600 amps is seventy-six (76) inches.
- 615.25 **The preferred mounting height for wall-mounted CT cabinets on services rated up to 2,500 amps is eighty-four (84) inches.** The maximum mounting height for wall-mounted CT cabinets on services rated up to 2,500 amps is ninety (90) inches. The minimum mounting height for wall-mounted CT cabinets on services rated up to 2,500 amps is eighty (80) inches.
- 615.26 No wall-mounted CT cabinet shall be installed with the floor or bottom of the enclosure less than sixteen (16) inches above the finished grade or standing surface immediately in front of the cabinet. Within the Chugach service area the bottom of the enclosure may be reduced to a twelve (12) inch clearance provided that the bottom of the access doors meet the sixteen (16) inch minimum clearance requirement.
- 615.27 There is no similar or equivalent EUSERC Drawing for this service equipment specification.

SECTION 600 - SERVICE EQUIPMENT SPECIFICATIONS

616 Standard Switchboard Service Section with CT Compartment

- 616.1 A socket meter panel with blank meter panel is shown in the following diagram. A fifteen (15)-inch hinged meter panel meeting the requirements of Section 618 shall be provided. The blank meter panel shall be constructed of twelve (12) gauge (minimum thickness) steel.
- 616.2 Meter panels shall be equipped with stops to prevent inward swinging beyond the front surface of the service section.
- 616.3 Hinges shall be readily interchangeable, left or right, on the job site.
- 616.4 Removable or hinged panels enclosing unmetered bus or cable shall be sealable.
- 616.5 For CT compartment requirements, see:
- a) 201 amps to 1,000 amps, Section 620.
 - b) 1,001 amps to 3,000 amps, Section 621.
 - c) 3,001 amps to 4,000 amps, Section 622.
- 616.6 When used as a utility terminating section in a bottom-fed service section, refer to requirements for a combination switchboard service section and pull section in Section 625.
- 616.7 The dimension shown in the diagram on the following page referencing Subsection 616.7 may be reduced if the service section is supplied from horizontal cross-bussing or bus duct.
- 616.8 The Utility requires switchboard service sections, including service termination sections, metering sections, and meter disconnect sections to be located outdoors on the exterior of the customer's building or structure. Refer to requirements for outdoor enclosures for switchboards in Section 619.
- 616.9 CT compartments in switchboard service sections shall have hinged front cover access doors (hinged meter panel and hinged blank panel) meeting the requirements of Section 618. The hinged meter panel and hinged blank panel which comprise the front cover access doors for the CT compartment **shall be lockable** and shall accept a padlock with a shackle diameter of not less than five-sixteenths (5/16) inch.
- 616.10 Switchboard service sections shall meet the general requirements of Section 310.
- 616.11 This service equipment specification is similar to EUSERC Drawing 325.

SECTION 600 - SERVICE EQUIPMENT SPECIFICATIONS

616 Standard Switchboard Service Section with CT Compartment

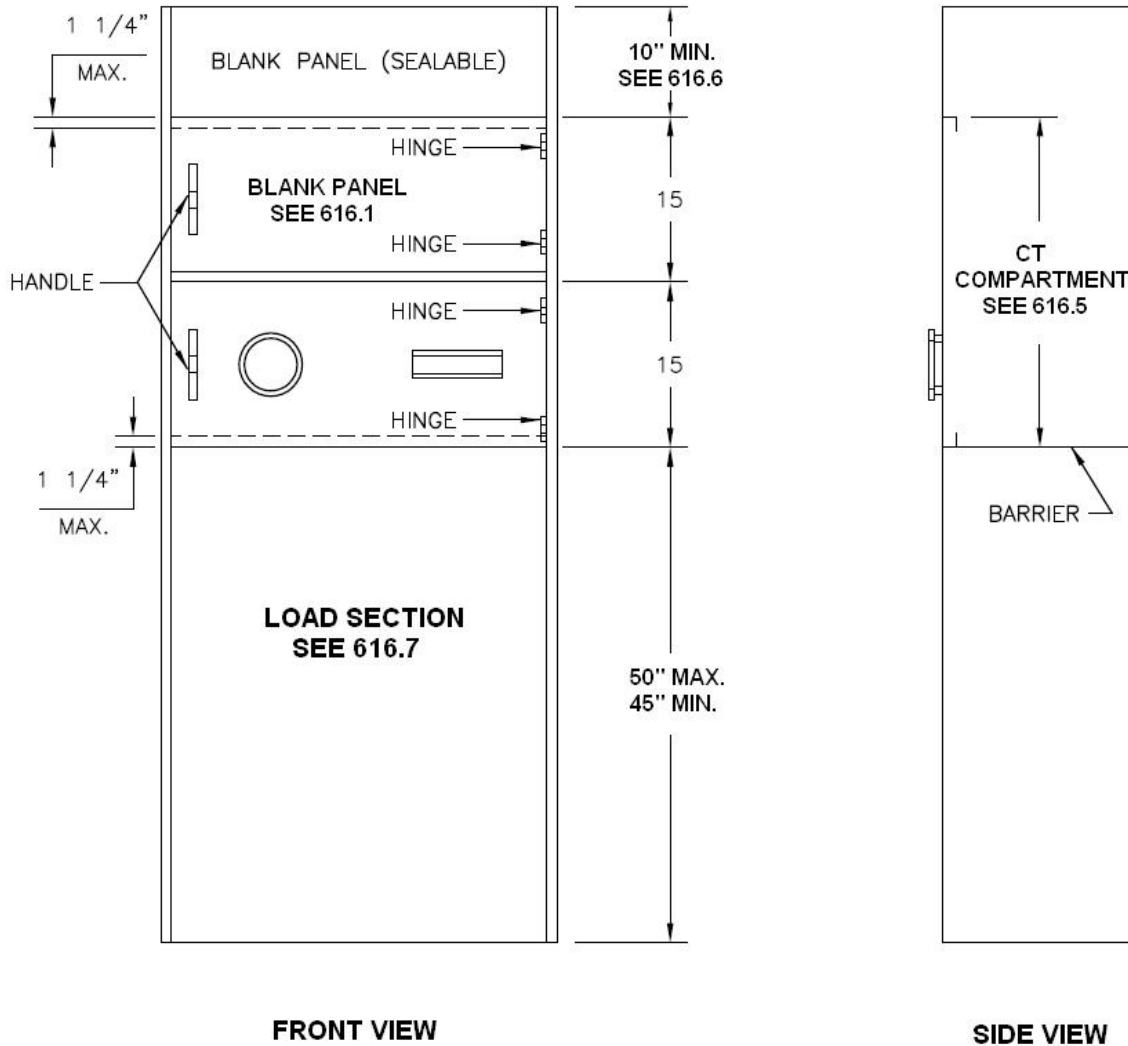

ALL DIMENSIONS SHOWN ARE IN INCHES

SECTION 600 - SERVICE EQUIPMENT SPECIFICATIONS

617 Standard Switchboard Service Section with CT Compartment and Filler Panel

- 617.1 A socket meter panel with blank meter panel is shown in the following diagram. A fifteen (15) inch hinged meter panel meeting the requirements of Section 618 shall be provided. The blank meter panel shall be constructed of twelve (12) gauge (minimum thickness) steel.
- 617.2 Filler panels shall be used where the service section width exceeds the meter panel width. Meter panels, either socket or blank, shall not be hinged to hinged filler panels. Non-hinged filler panels shall not extend into the required CT compartment access opening.
- 617.3 Meter panels and filler panels shall be equipped with stops to prevent inward swinging beyond the front surface of the service section.
- 617.4 Hinges shall be readily interchangeable, left or right, on the job site.
- 617.5 Removable or hinged panels enclosing unmetered bus or cable shall be sealable.
- 617.6 For CT compartment requirements, see:
- a) 201 amps to 1,000 amps, Section 620.
 - b) 1,001 amps to 3,000 amps, Section 621.
 - c) 3,001 amps to 4,000 amps, Section 622.
- 617.7 The ten (10) inch minimum vertical dimension shown in the following diagram may be reduced if the service section is supplied from horizontal cross-bussing or bus duct.
- 617.8 When used as a utility terminating section in a bottom-fed service section, refer to requirements for a combination switchboard service section and pull section in Section 625.
- 617.9 The Utility requires switchboard service sections, including service termination sections, metering sections, and meter disconnect sections to be located outdoors on the exterior of the customer's building or structure. Refer to requirements for outdoor enclosures for switchboards in Section 619.
- 617.10 CT compartments in switchboard service sections shall have hinged front cover access doors (hinged meter panel and hinged blank panel) meeting the requirements of Section 618. The hinged meter panel and hinged blank panel which comprise the front cover access doors for the CT compartment **shall be lockable** and shall accept a padlock with a shackle diameter of not less than five-sixteenths (5/16) inch.
- 617.11 Switchboard service sections shall meet the general requirements of Section 310.
- 617.12 This service equipment specification is similar to EUSERC Drawing 326.

SECTION 600 - SERVICE EQUIPMENT SPECIFICATIONS

617 Standard Switchboard Service Section with CT Compartment and Filler Panel

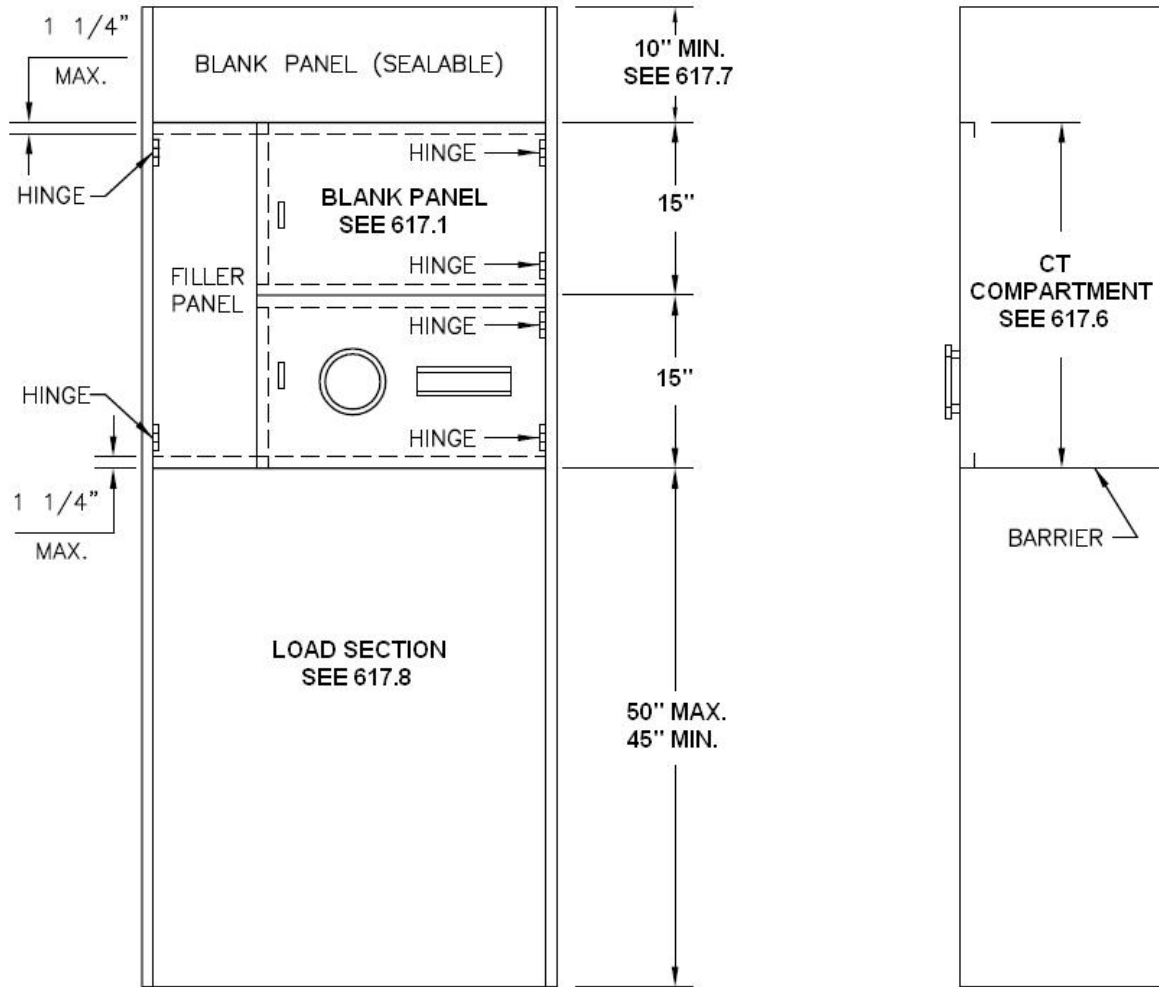

FRONT VIEW

SIDE VIEW

ALL DIMENSIONS SHOWN ARE IN INCHES

SECTION 600 - SERVICE EQUIPMENT SPECIFICATIONS

618 Switchboard Service Section 15-inch Hinged Meter Panel

618.1 The panel shall be constructed of twelve (12) gauge (minimum) steel and shall be hinged at the test switch side by the manufacturer. The panel shall be furnished with a meter socket, sealing ring, and a slotted opening and removable plate for the installation of a secondary test switch. The slotted opening and removable plate edges shall be smooth to prevent damage to meter wiring.

Note: When a cast meter mounting ring is provided, the screws used to attach to the meter panel shall provide a minimum one-eighth (1/8)-inch clearance between the screw heads and the block of the ring.

618.2 The removable plate shall be attached to the rear of the panel with screws that do not protrude through the face of the panel.

618.3 The meter socket shall be designed for back connection.

618.4 The panel shall be equipped with hinges. The hinges shall permit the panel to open to ninety (90) degrees, and shall be readily interchangeable, right or left, on the meter socket panel. For clevis or removable type hinges, the pin shall be removable from the top.

618.5 The panel shall be equipped with a handle on the unsupported end. The handle shall be interchangeable, right or left, on the meter socket panel and maintain a one (1) inch minimum clearance from the meter socket flange and slotted opening.

618.6 The panel shall support a twenty-five (25)-pound load applied at the unsupported end when fully opened with maximum sag of one-eighth (1/8) inch.

618.7 Stud and wing nut assemblies shall be sealable when used.

618.8 The meter socket shall be thirteen (13)-terminal in accordance with ANSI C12.10.

618.9 The hinged meter panel and hinged blank panel which comprise the front cover access doors for the switchboard service section's CT compartment shall be lockable and shall accept a padlock with a shackle diameter of not less than five-sixteenths (5/16) inch.

618.10 The positioning of the handle on the unsupported end of the fifteen (15)-inch hinged meter panel and its corresponding blank panel shall provide sufficient clearance for use of the handle and sufficient clearance for easily installing and removing the padlock from the locking provisions.

618.11 Locking provisions for the fifteen (15)-inch hinged meter panel and its corresponding hinged blank panel shall be OEM, provided and installed by the switchboard manufacturer. Field retrofitting and field fabrication of locking provisions for these panels **is not** acceptable.

618.12 The fifteen (15)-inch hinged meter panel, the hinged blank panel, and related components which comprise the front cover access doors for the switchboard service section's CT compartment shall meet the sealing and locking requirements of Section 305.

618.13 All switchboard service section fifteen (15)-inch hinged meter panels and related components shall meet the general requirements of Section 310.

618.14 This service equipment specification is similar to EUSERC Drawing 332.

SECTION 600 - SERVICE EQUIPMENT SPECIFICATIONS

619 Outdoor Enclosures for Switchboards

- 619.1 Hinged meter panels shall be capable of being opened ninety (90) degrees with the meter and test switch assembly in place, and provide the following clearances to any obstruction: eleven (11) inches at the meter socket and four (4) inches at the test switch slotted opening. See Section 618 for hinged meter panel construction details.
- 619.2 Meter panels, either socket or blank, shall not be hinged to a hinged filler panel. Non-hinged filler panels shall not extend into the required CT compartment access opening.
- 619.3 Enclosure doors providing access to utility compartments (i.e. metering sections and pull sections) shall be:
- a) Equipped with a device to secure the doors in the open position at ninety (90) degrees or more.
 - b) Secured in the closed position with a single, handle-operated latching system. When provided with a locking means, each door or set of doors shall be equipped with an approved double-locking device, accepting padlocks with a shackle diameter of five-sixteenths (5/16) inch, to allow access by both the Utility and the customer.
- 619.4 The dimension may be reduced if the service section is supplied from horizontal cross-bussing or bus duct.
- 619.5 Switchboard service sections and related components shall meet the general requirements of Section 310.
- 619.6 Seals and locks to secure panel covers and compartment doors of unmetered conductors or bus (utility's line-side) are permitted to be concealed by the outer enclosure doors of the outdoor enclosure of the switchboard service section. Seals and locks may not be concealed by panel covers and compartment doors of metered conductors or bus (customer's load-side).
- 619.7 Hinged outer doors **shall be** properly aligned and adjusted for ease of operation. Doors and panels that require **pounding, hammering, and/or prying** to open, close, operate, or remove, **are not acceptable**. The Utility will not energize switchboard service sections until it has been demonstrated that all doors and panel covers operate in an appropriate manner.
- 619.8 This service equipment specification is similar to EUSERC Drawing 354.

SECTION 600 - SERVICE EQUIPMENT SPECIFICATIONS

619 Outdoor Enclosures for Switchboards

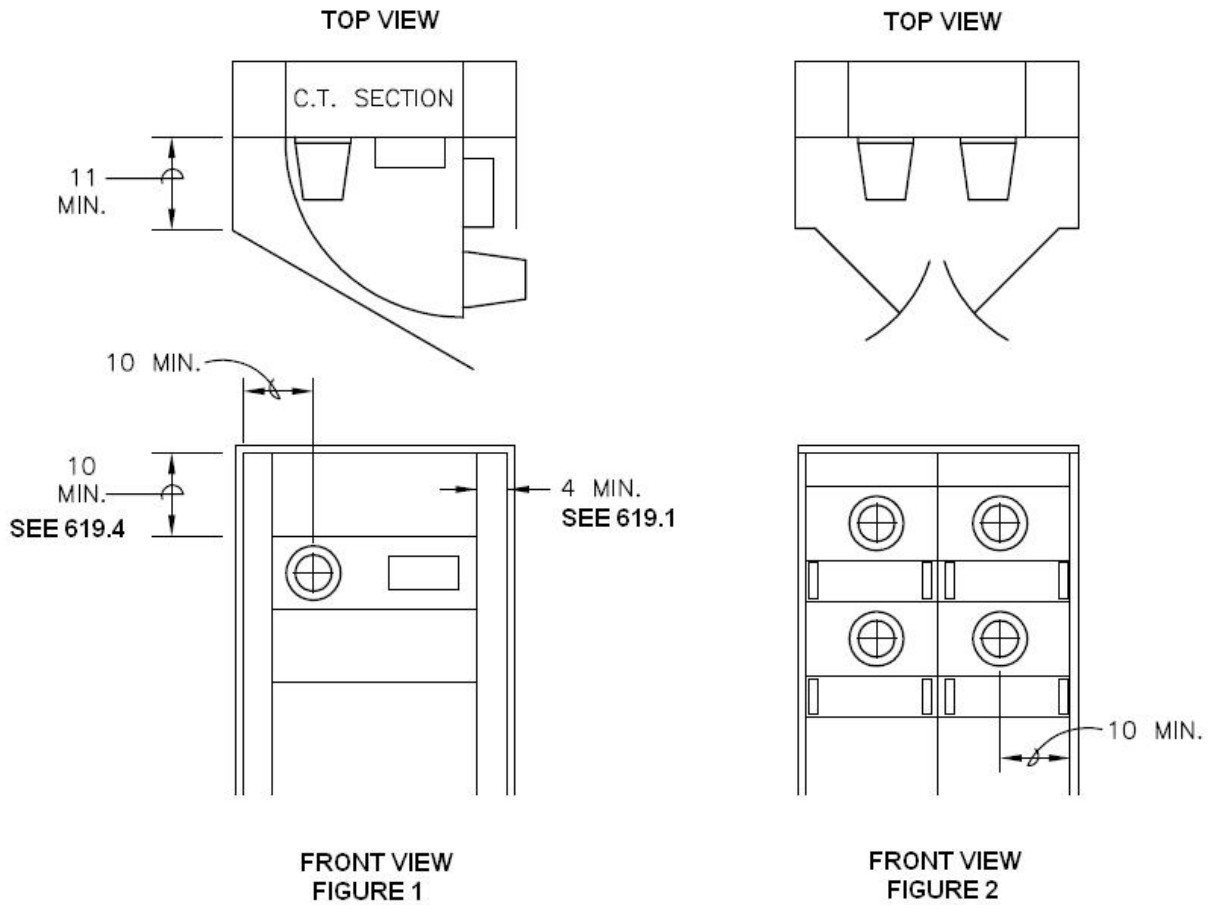

ALL DIMENSIONS SHOWN ARE IN INCHES

SECTION 600 - SERVICE EQUIPMENT SPECIFICATIONS

620 CT Compartment for Switchboards, 201 Amps to 1,000 Amps

- 620.1 Bus arrangements and supports shall be provided as shown in the following diagram, except the neutral bus may be located at either side or either side wall. Bus supports shall be constructed of a continuous bar of insulating material and shall be rigid to prevent misalignment of the bus units with the cables in place.
- 620.2 The bus units may be supplied from the top or bottom and shall be anchored to prevent turning. Bus units shall be constructed of rectangular bus and when laminated shall have no space between laminations. Bus dimensions shall be a minimum of one-quarter (1/4) inch x two (2) inches and a maximum of three-quarter (3/4) inch x two (2) inches.
- 620.3 Bus unit shall be provided with a fixed stud as shown in the following diagram for mounting the CTs. Each fixed stud shall consist of a one-half (1/2)-inch steel bolt and shall be provided with a spring washer and a nut. The spring washer may be either a cone-type (Belleville) washer or a split ring washer and a flat washer. All parts shall be plated to prevent corrosion. Each fixed stud shall be secured in place so that the stud will not turn, back out, or loosen in any manner when tightening or loosening the associated nuts (including cross threaded situations).
- 620.4 When the compartment is supplied from horizontal cross-bussing, the bussing shall pass through the compartment or in the sealed area above the compartment.
- 620.5 Except for conductors supplying the CT compartment, and the ground bus, no other conductors or devices shall be installed in or routed through the compartment or the sealed area above the compartment. The ground bus shall not infringe on utility compartment space or reduce any clearances. Customer connections to the ground bus shall not be allowed in the CT compartment.
- 620.6 A clear unobstructed work space shall be provided around the CT bus units from the barrier to the upper support bar.
- 620.7 Taps for attachment of meter wiring shall be provided on the neutral bus unit shown, or when the compartment is supplied from cross bussing, a tap may be provided on the neutral cross bus, or on a bus bar extension provided from the neutral cross bus. A 10-32 screw and washer shall be provided for the neutral bus. Tap locations shall be centered between phase bus units, or at either side, and shall be readily accessible under energized conditions and with the CTs in place.
- 620.8 The barrier shall be constructed of a rigid insulating material resistant to arc tracking, and shall be secured in place with a maximum deflection of one-half (1/2) inch from an applied force of twenty-five (25) pounds downward. Openings in the barrier (i.e., peripheral gaps around the barrier, cutouts around bus bars, and hole diameters provided for ventilation) shall not exceed three-eighths (3/8) inch. The barrier shall be attached with non-conductive fasteners.
- 620.9 A removable link shall be installed in the right side phase bus for 3-phase, 3-wire service.
- 620.10 The power leg (wild leg) bus for a 4-wire delta service shall be identified by an orange outer finish or by tagging or by other effective means.
- 620.11 Dimensions are measured to the inside edge of the compartment access opening.
- 620.12 CT compartment covers for switchboards (hinged meter panels) **shall be** lockable and shall accept a padlock with a shackle diameter of five-sixteenths (5/16) inch.
- 620.13 Switchboard service sections and related components shall meet the general requirements of Section 310.
- 620.14 This service equipment specification is similar to EUSERC Drawing 320.

SECTION 600 - SERVICE EQUIPMENT SPECIFICATIONS

621 CT Compartment for Switchboards, 1,001 Amps to 3,000 Amps

- 621.1 Bus arrangements and supports shall be provided as shown in the following diagram, except the neutral bus may be located at either side or on either side wall. Bus units shall be anchored so that busses will remain in position when section "B" is removed. For details of section "B" and the insulated CT support, see Section 623. Bus supports shall be constructed of a continuous bar of insulating material.
- 621.2 The bus units may be supplied from the top or bottom, and shall be constructed of rectangular bus. Maximum allowable bus size shall be four one-quarter (1/4)-inch x four (4)-inch bars spaced one-quarter (1/4) inch apart.
- 621.3 Bus units shall be insulated as shown and the insulating material shall be rated for the serving voltage. Round bus corners as necessary to prevent damage to insulation.
- 621.4 When the compartment is supplied from horizontal cross-bussing, the bussing shall pass through the compartment or in the sealed area above the compartment.
- 621.5 Except for bus supplying the CT compartment and the ground bus, no other conductors or devices shall be installed in, or routed through the compartment or the sealed area above the compartment. The ground bus shall not infringe on utility compartment space or reduce any clearances. Customer connections to the ground bus shall not be allowed in the CT compartment.
- 621.6 A clear unobstructed work space shall be provided around the CT bus units from the barrier to two (2) inches above the removable CT bus sections ("B").
- 621.7 Taps for attachment of meter wiring shall be provided. A tap shall be provided on each upper and lower phase bus unit with a 10-32 screw and washer provided for each phase bus in either the upper or lower position. A tap shall be provided on the neutral bus as shown, or when the compartment is supplied from cross-bussing, a tap may be provided on the neutral cross-bus, or on a bus bar extension provided from the neutral cross-bus. A 10-32 screw and washer shall be provided for the neutral bus. Tap locations shall be centered between phase bus units, or at either side, and shall be readily accessible under energized conditions and with CTs in place.
- 621.8 The barrier shall be constructed of a rigid insulating material resistant to arc tracking and shall be secured in place with a maximum deflection of one-half (1/2) inch from an applied force of twenty-five (25) pounds downward. Openings in the barrier (i.e., peripheral gaps around barrier, cutouts around bus bars, and hole diameters provided for ventilation) shall not exceed three-eighths (3/8) inch. The barrier shall be attached with non-conductive fasteners.
- 621.9 Dimensions are measured to the inside edge of the compartment access opening.
- 621.10 CT compartment covers for switchboards (hinged meter panels) **shall be** lockable and shall accept a padlock with a shackle diameter of five-sixteenths (5/16) inch.
- 621.11 Switchboard service sections and related components shall meet the general requirements of Section 310.
- 621.12 This service equipment specification is similar to EUSERC Drawing 322.

SECTION 600 - SERVICE EQUIPMENT SPECIFICATIONS

621 CT Compartment for Switchboards, 1,001 Amps to 3,000 Amps

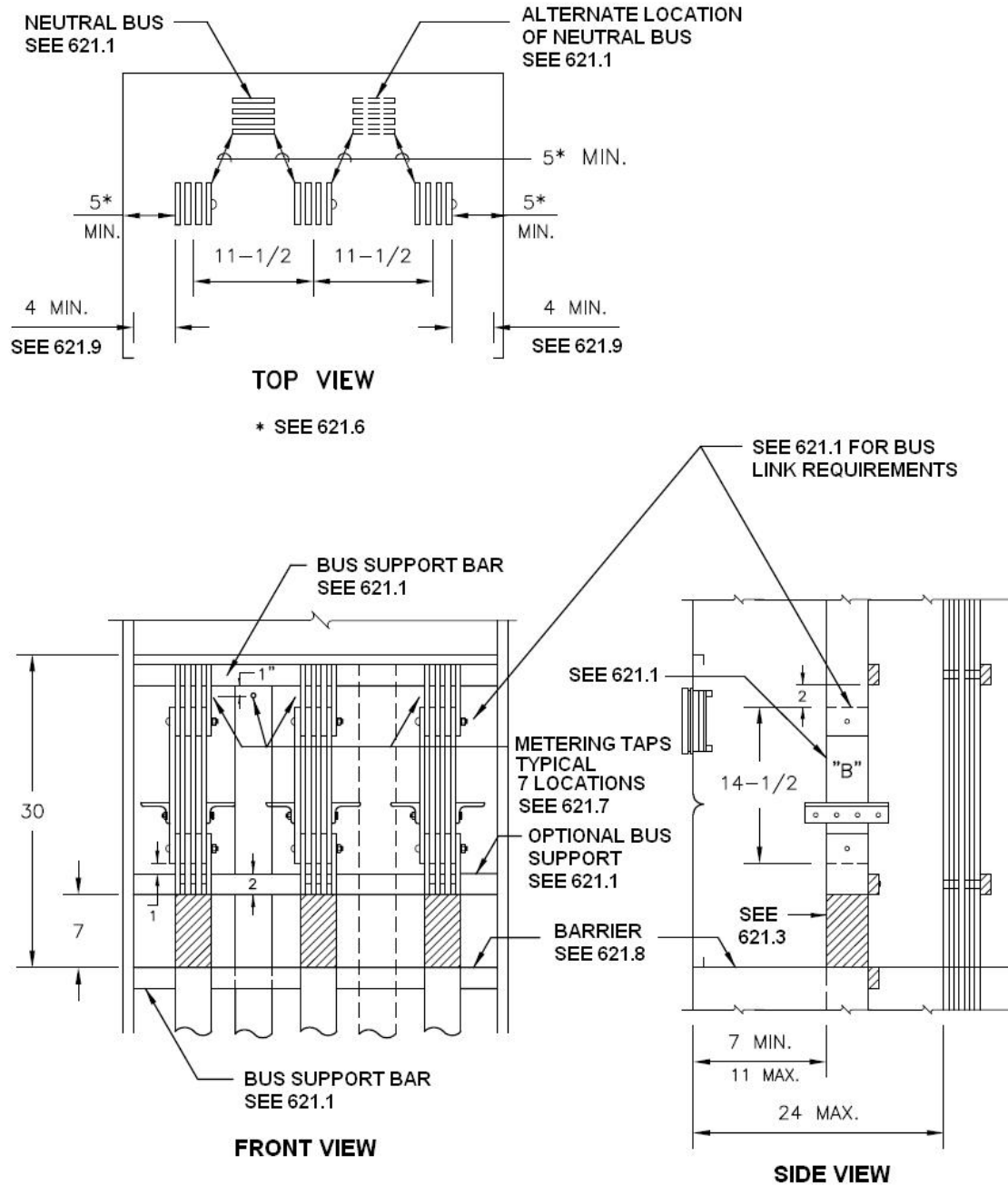

ALL DIMENSIONS SHOWN ARE IN INCHES

SECTION 600 - SERVICE EQUIPMENT SPECIFICATIONS

622 CT Compartment for Switchboards, 3,001 Amps to 4,000 Amps

- 622.1 Bus arrangements and supports shall be provided as shown in the following diagram, except the neutral bus may be located at either side or on either side wall. Bus units shall be anchored so that busses will remain in position when section "B" is removed. For details of section "B" and the insulated CT support, see Section 623 for 4-inch bus specifications and Section 624 for 5-inch bus specifications. Bus supports shall be constructed of a continuous bar of insulating material.
- 622.2 The bus units may be supplied from the top or bottom, and shall be constructed of rectangular bus. For maximum allowable bus sizes, see Table 1 on the following page.
- 622.3 Bus units shall be insulated as shown and the insulating material shall be rated for the serving voltage. Round bus corners as necessary to prevent damage to insulation.
- 622.4 When the compartment is supplied from horizontal cross-bussing, the bussing shall pass through the compartment or in the sealed area above the compartment.
- 622.5 Except for bus supplying the CT compartment and the ground bus, no other conductors or devices shall be installed in, or routed through the compartment or the sealed area above the compartment. The ground bus shall not infringe on utility compartment space or reduce any clearances. Customer connections to the ground bus shall not be allowed in the CT compartment.
- 622.6 A clear unobstructed work space shall be provided around the CT bus units from the barrier to two (2) inches above the removable CT bus sections ("B").
- 622.7 Taps for attachment of meter wiring shall be provided. A tap shall be provided on each upper and lower phase bus unit with a 10-32 screw and washer provided for each phase bus in either the upper or lower position. A tap shall be provided on the neutral bus as shown, or when compartment is supplied from cross-bussing, a tap may be provided on the neutral cross-bus, or on a bus bar extension provided from the neutral cross-bus. A 10-32 screw and washer shall be provided for the neutral bus. Tap locations shall be centered between phase bus units, or at either side, and shall be readily accessible under energized conditions and with CTs in place.
- 622.8 The barrier shall be constructed of a rigid insulating material resistant to arc tracking and shall be secured in place with a maximum deflection of one-half (1/2) inch from an applied force of twenty-five (25) pounds downward. Openings in the barrier (i.e., peripheral gaps around barrier, cutouts around bus bars, and hole diameters provided for ventilation) shall not exceed three-eighths (3/8) inch. The barrier shall be attached with non-conductive fasteners.
- 622.9 Dimensions are measured to the inside edge of the compartment access opening.
- 622.10 CT compartment covers for switchboards (hinged meter panels) **shall be** lockable and shall accept a padlock with a shackle diameter of five-sixteenths (5/16) inch.
- 622.11 Switchboard service sections and related components shall meet the general requirements of Section 310.
- 622.12 This service equipment specification is similar to EUSERC Drawing 324.

SECTION 600 - SERVICE EQUIPMENT SPECIFICATIONS

622 CT Compartment for Switchboards, 3,001 Amps to 4,000 Amps

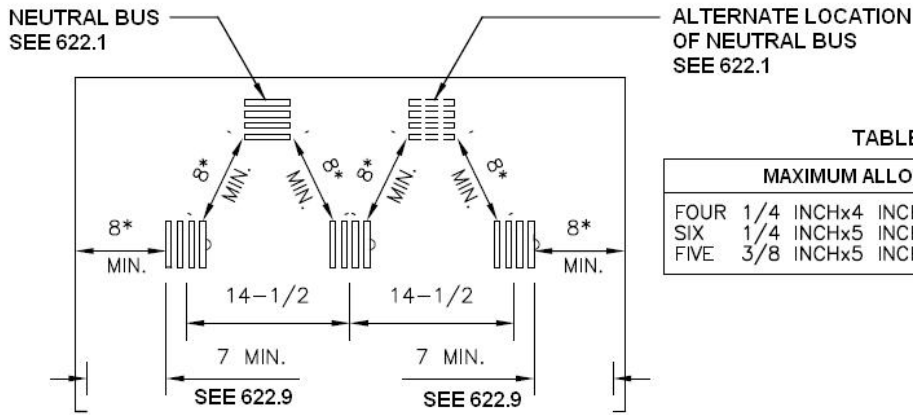

TOP VIEW

* SEE 622.6

TABLE 1

MAXIMUM ALLOWABLE BUS					
FOUR	1/4	INCHx4	INCH	BARS SPACED	1/4
SIX	1/4	INCHx5	INCH	BARS SPACED	1/4
FIVE	3/8	INCHx5	INCH	BARS SPACED	3/8

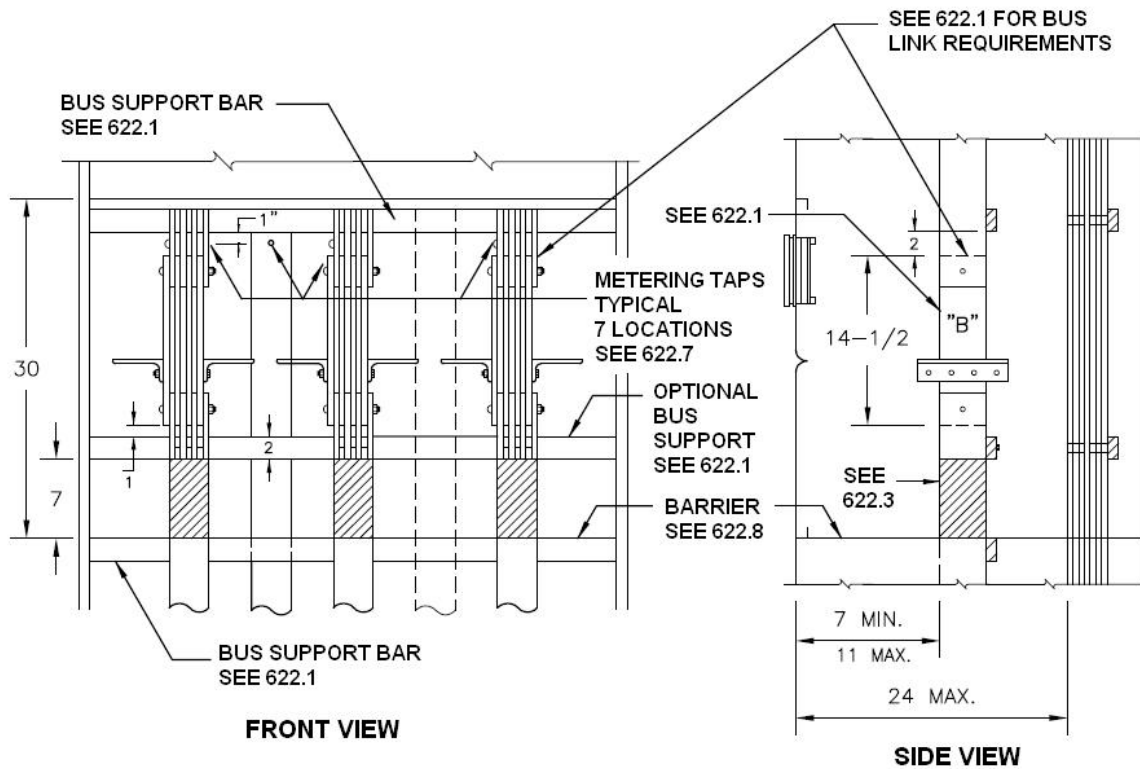

ALL DIMENSIONS ARE IN INCHES

SECTION 600 - SERVICE EQUIPMENT SPECIFICATIONS

623 Removable Bus Link and CT Support with 4-inch Bus

- 623.1 The manufacturer is required to secure the removable bus link to the upper and lower CT bus units using one-half (1/2)-inch hex-head bolts, nuts (as shown) with a spring washer and a nut. The spring washer may be either a cone-type (Belleville) or a split ring washer with a flat washer. Bolts shall be grade 5 (minimum) and washers (Belleville or flat) shall be two-and-one-quarter (2-1/4) inches (minimum).
- 623.2 Drill and tap two holes as shown in the following diagram on the outer bus units for 1/4-inch x 20 cap screws.
- 623.3 CTs shall be centered on the bus and shall be attached to the insulated supports at a minimum of two (2) locations.
- 623.4 This service equipment specification is similar to EUSERC Drawing 330.

SECTION 600 - SERVICE EQUIPMENT SPECIFICATIONS

623 Removable Bus Link and CT Support with 4-inch Bus

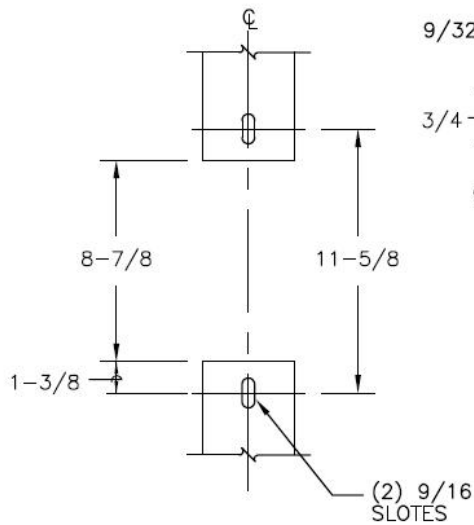

DETAIL "A"
DRILLING AND SPACING OF BUS

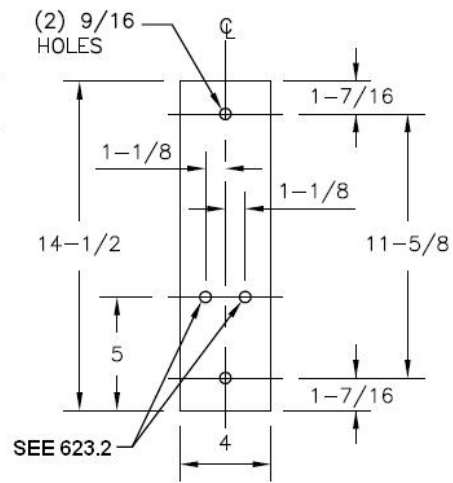

DETAIL "B"
1/4x4 LINK
(SAME MATERIAL AS BUS)

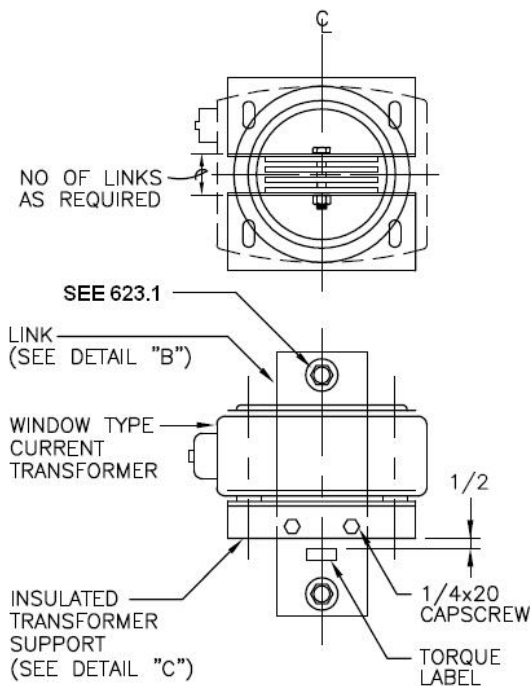

REMOVABLE LINK
(FURNISHED BY MANUFACTURER)

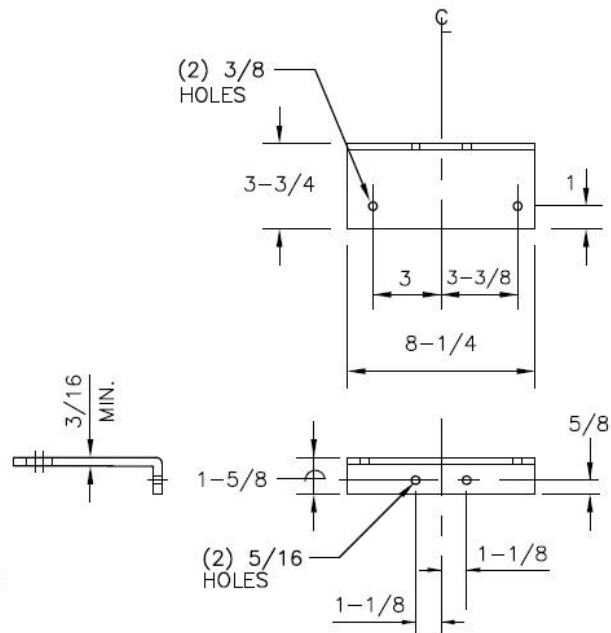

DETAIL "C"
INSULATED SUPPORT FOR
CURRENT TRANSFORMER
(MATERIAL: INSULATING, NON-TRACKING)

ALL DIMENSIONS SHOWN ARE IN INCHES

SECTION 600 - SERVICE EQUIPMENT SPECIFICATIONS

624 Removable Bus Link and CT Support with 5-inch Bus

- 624.1 The manufacturer is required to secure the removable bus link to the upper and lower CT bus units using one-half (1/2)-inch hex-head bolts, nuts (as shown) with a spring washer and a nut. The spring washer may be either a cone-type (Belleville) or a split ring washer with a flat washer. Bolts shall be grade 5 (minimum) and washers (Belleville or flat) shall be two-and-one-quarter (2-1/4) inches (minimum).
- 624.2 Drill and tap two holes as shown in the following diagram on the outer bus units for 1/4-inch x 20 cap screws.
- 624.3 CTs shall be centered on the bus and shall be attached to the insulated supports at a minimum of two (2) locations.
- 624.4 This service equipment specification is similar to EUSERC Drawing 331.

SECTION 600 - SERVICE EQUIPMENT SPECIFICATIONS

624 Removable Bus Link and CT Support with 5-inch Bus

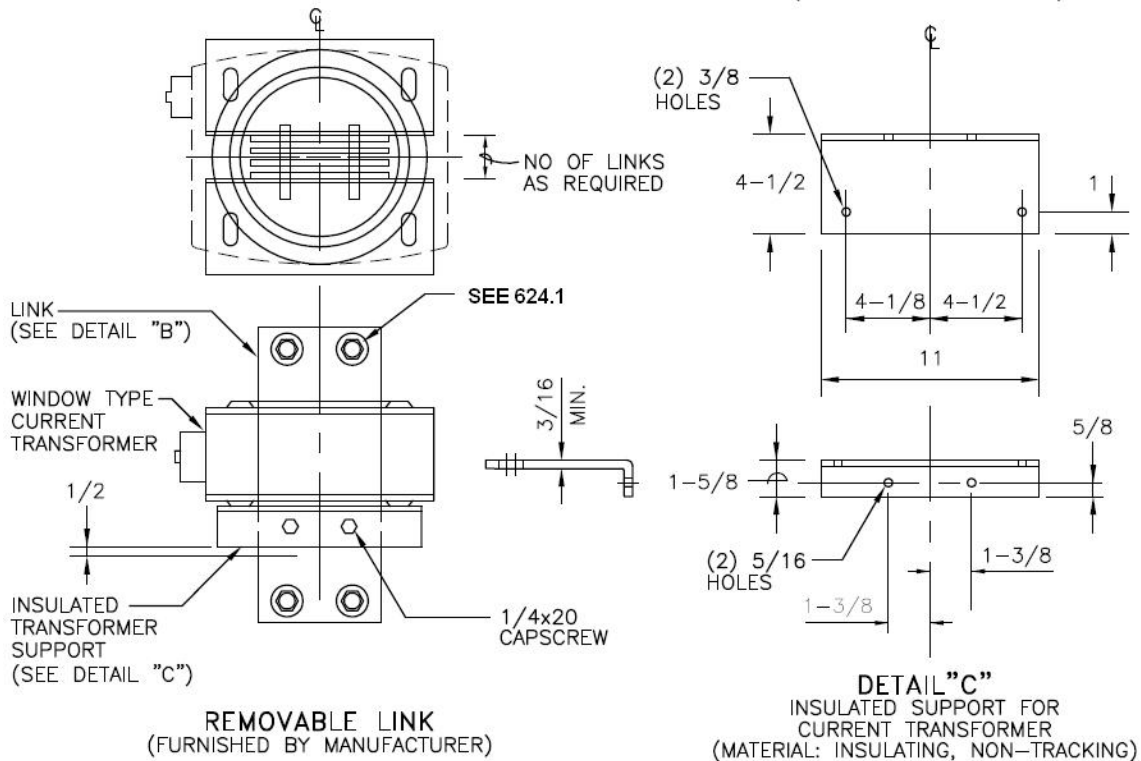
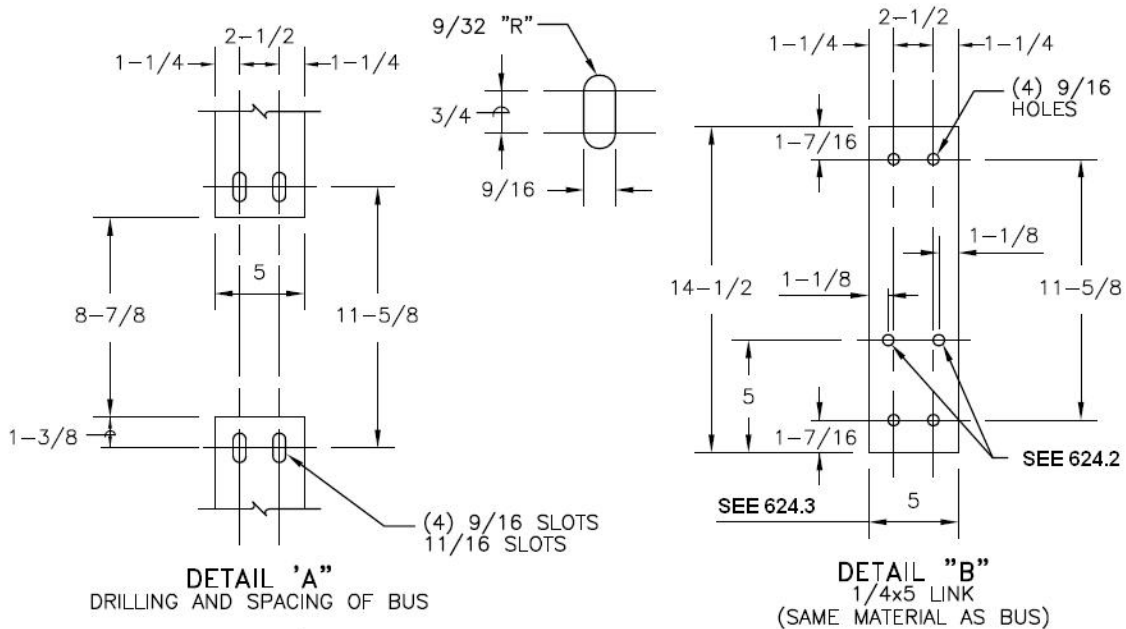

ALL DIMENSIONS SHOWN ARE IN INCHES

SECTION 600 - SERVICE EQUIPMENT SPECIFICATIONS

625 Combination Switchboard Service Section and Pull Section

- 625.1 The pull section may supply either a CT compartment or a main service disconnect device.
- 625.2 Pull section covers shall be:
- a) Independent of other equipment and removable without disturbing adjacent panels.
 - b) Sealable, provided with two (2) lifting handles, and limited to a maximum of nine (9) square feet in area.
- 625.3 The panel shall be equipped with terminating facilities complying with Section 627. Terminating facilities shall be secured to prevent misalignment and shall be rigid without the installation of CTs.
- 625.4 The clearance from the energized bus to the pull section removable access covers may be reduced if a safety barrier is provided by the manufacturer. For additional clearance and barrier requirements, see Subsection 627.12.
- 625.5 A vertical clearance of three (3) inches minimum shall be maintained between the centerline of the top bolts of the terminating facilities to any obstruction.
- 625.6 When the upper section is:
- a) A CT compartment, see Sections 616 and 617 for additional service section requirements.
 - b) A main service disconnect device:
 - 1) A full width and depth, insulated rigid barrier shall be provided to separate the pull section and main service disconnect compartment.
 - 2) The main service disconnect cover shall be sealable.
- 625.7 Sealing provisions for removable covers shall consist of two drilled stud and wing-nut assemblies located on opposite sides of the cover. Hinged covers shall be sealed on the unsupported side.
- 625.8 The minimum pull access opening (W) is measured between the left side and right side return flanges.
- 625.9 Refer to Section 626, Table 1, on page 195 for terminating height ("X" dimension) requirements.
- 625.10 Switchboard service sections and related components shall meet the general requirements of Section 310.
- 625.11 This service equipment specification is similar to EUSERC Drawing 327.

SECTION 600 - SERVICE EQUIPMENT SPECIFICATIONS

625 Combination Switchboard Service Section and Pull Section

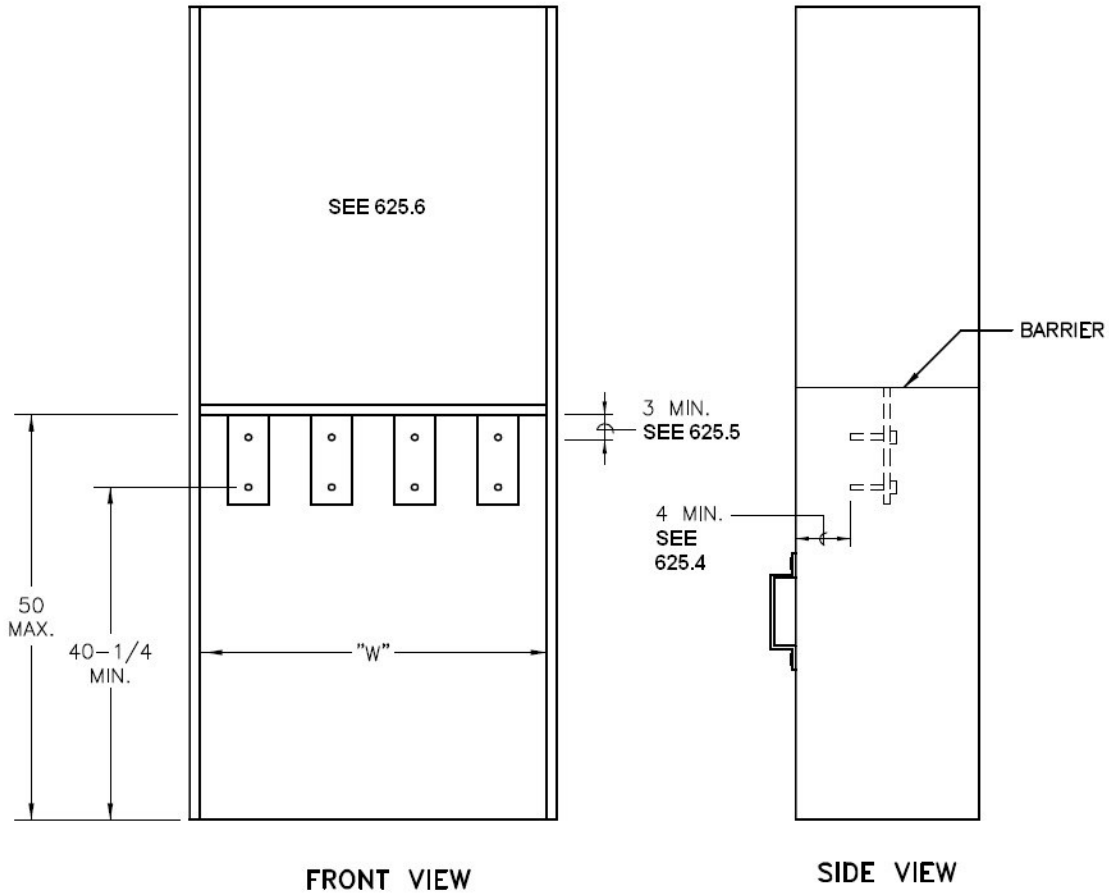

TABLE 1 - MINIMUM DIMENSIONS

SWITCHBOARD RATING (AMPERES)	MINIMUM ACCESS OPENING DIMENSION (W) - SEE 625.8	
	3-WIRE	4-WIRE
BELOW 400	CONSULT WITH THE UTILITY	
400 - 800	24	24
801 - 1200	24	30
1201 - 2000	30	35

ALL DIMENSIONS SHOWN ARE IN INCHES

SECTION 600 - SERVICE EQUIPMENT SPECIFICATIONS

626 Underground Service Termination - Switchboard Service Section

- 626.1 A switchboard pull section as shown on the following page in Figure 1, a separate (non-attached) termination enclosure as shown in Figure 2, or a combination switchboard service section and pull section (bottom feed) as shown in Figure 3 shall be provided for underground services.
- 626.2 Bus bars or cables may extend from the pull section into switchboard service sections rated up to 800 amps. Bus bars are required when the service section rating exceeds 800 amperes or multiple metering is supplied.
- 626.3 When the service section is supplied from a switchboard pull section as shown in Figure 1, the bus bars or cables shall enter through the side or back of the sealable section above the CT compartment, or by means of horizontal cross-bussing in back of the metering compartment.
- 626.4 When horizontal cross-bussing exits the switchboard pull section below the terminating facilities, the lowest cross-bus unit and the transition bussing supplying the cross-bus units shall not be less than two (2) feet above the bottom of the enclosure or more than eight (8) inches from the back of the enclosure.
- 626.5 The minimum pull section access opening (W) is measured between the left side and right side return flanges.
- 626.6 All switchboard service sections shall be "front only accessible" such that all line connections can be made from the front of the switchboard.
- 626.7 All terminating enclosures (i.e. pull boxes and pull sections) shall have full front access. Cover panels shall be removable, sealable, provided with two (2) lifting handles, and limited to a maximum of nine (9) square feet in area.
- 626.8 Sealing provisions shall consist of two (2) drilled stud and wing nut assemblies on opposite sides of the panels.
- 626.9 See Section 627 for construction details and clearance requirements for terminating facilities in pull boxes and pull sections.
- 626.10 Ground bus, when provided, shall be located at the rear of the terminating enclosure.
- 626.11 CT compartments shall have hinged front cover access doors. The hinged front cover access doors for the CT compartment shall be lockable and shall accept a padlock with a shackle diameter of five-sixteenths (5/16) inch.
- 626.12 Except where otherwise specified in this book, the term "Standing Surface" as used in this service equipment specification on the following page refers to the surface on which the switchboard service section is mounted (e.g. concrete base or pad).
- 626.13 Switchboard service sections and related components shall meet the general requirements of Section 310.
- 626.14 This service equipment specification is similar to EUSERC Drawing 345.

SECTION 600 - SERVICE EQUIPMENT SPECIFICATIONS

626 Underground Service Termination - Switchboard Service Section

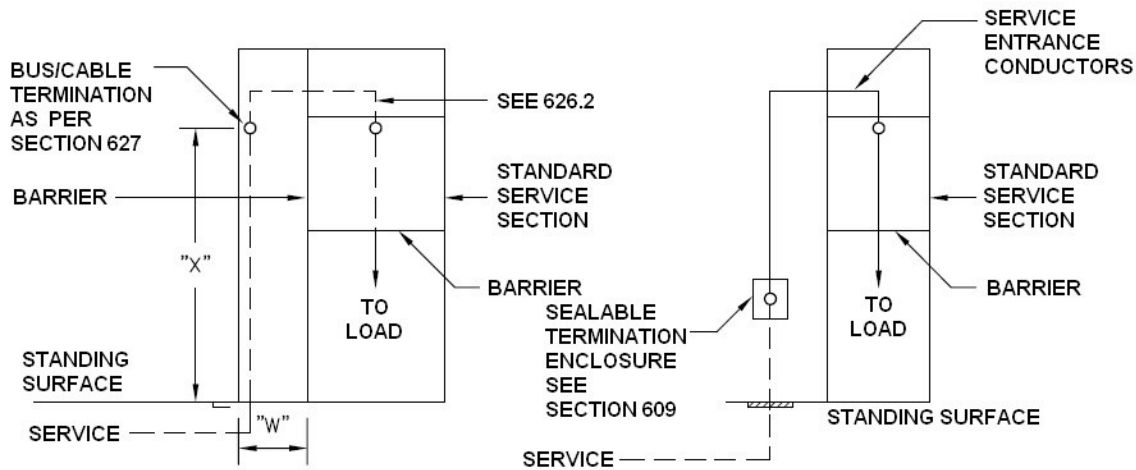

FIGURE 1
SWITCHBOARD
PULL SECTION

FIGURE 2
1200 AMP MAXIMUM

SEPARATE TERMINATION
ENCLOSURE

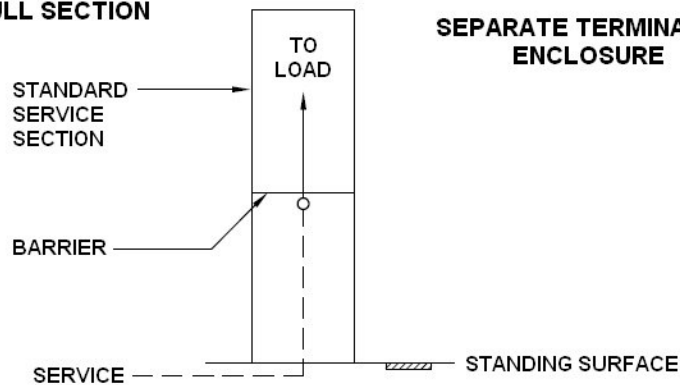

FIGURE 3
2000 AMP MAXIMUM
SEE SECTION 625 FOR PULL SECTION REQUIREMENTS

BOTTOM FEED PULL SECTION

TABLE 1 MINIMUM PULL BOX DIMENSIONS - SEE 626.5

SWITCHBOARD RATING (AMPERES)	MINIMUM ACCESS OPENING DIMENSION (W) - SEE 626.4		TERMINATION HEIGHT (X)
	3-WIRE	4-WIRE	
BELOW 400	CONSULT WITH THE UTILITY'S ENGINEERING DIVISION		
400 - 800	24	24	42 MIN. - 72 MAX.
801 - 1200	24	30	
1201 - 2000	30	35	
2001 - 3000	----	42	60 MIN. - 72 MAX.
3001 - 4000	----	44	60 MIN. - 72 MAX.

ALL DIMENSIONS SHOWN ARE IN INCHES

SECTION 600 - SERVICE EQUIPMENT SPECIFICATIONS

627 Underground Service Terminating Facilities in Pull Boxes or Pull Sections

627.1 One (1) landing position is required for each 400 amperes of service capacity or fraction thereof (i.e. one (1) position for up to 400 amperes, two (2) positions for 401 through 800 amperes, three (3) positions for 801 through 1,200 amperes, etc.). Each landing position shall consist of two (2) one-half (1/2)-inch steel bolts. The bolts shall extend from two (2) inches to two-and-one-half (2-1/2) inches from the mounting surface and be spaced on one-and-three-quarter (1-3/4) inch vertical centers. When multiple landing positions per phase are required, the horizontal spacing between bolt positions shall be two (2) inches as a minimum.

EXCEPTION: Edgewise terminating facilities may consist of nine-sixteenths (9/16) inch holes having the same spacing as specified for the one-half (1/2)-inch bolts as stated above and in Figure 1. The unobstructed working space shall be provided on both sides of the termination bus (see Figure 3).

627.2 Each terminating bolt shall be provided with a spring washer and a nut. The spring washer may be either a cone-type (Belleville) washer or a split ring washer and a flat washer. All parts shall be plated to prevent corrosion. "NOTE: When Belleville washers are used, the manufacturer shall provide a label with the required torque setting. This label shall be in a readily visible location within the compartment that the washers are being utilized." Terminating bolts shall not be used to secure the termination bus in place.

627.3 Termination bolts must be secured in place. "Secured in place" shall mean that the stud will not turn, back out, or loosen in any manner when tightening or loosening terminal nuts (including cross threaded situations).

627.4 In the terminal mounting area, which is defined as the area of the terminating facilities shown in Figure 1, a clear space (barrel of proximity) of one-and-one-half (1-1/2) inches minimum is required around any terminating facility including its bolts and bolt heads, any other bus, any other terminating facility, or any grounded surface. The one-and-one-half (1-1/2) inch minimum clear space may be reduced to one (1) inch as measured to the back of the pull section. The one-and-one-half (1-1/2) inch minimum clear space may also be reduced to one (1) inch when measured to any fully insulated horizontal buss behind the terminating facility. The neutral terminating facility may have a minimum clearance of one (1) inch from any grounded surface except:

- a) The minimum clearance to the back of the pull section may be reduced to one (1) inch.
- b) The minimum clearance to any fully insulated bus behind the terminating facility may be reduced to one (1) inch.
- c) The neutral terminating facility may have a minimum clearance from any grounded surface.

627.5 Each terminating facility shall have an unobstructed working space, accessible from the front of the pull section as viewed from the access compartment opening, in front of the entire mounting surface as shown in Figure 4.

EXCEPTION: For terminating facilities with bolts facing the access opening as shown in Figure 2 the required one-and-one-half (1-1/2) inch side clearance (bus to access opening return flange) may be reduced to three-quarters (3/4) inch.

(Continued on page 198)

SECTION 600 - SERVICE EQUIPMENT SPECIFICATIONS

627 Underground Service Terminating Facilities in Pull Boxes or Pull Sections

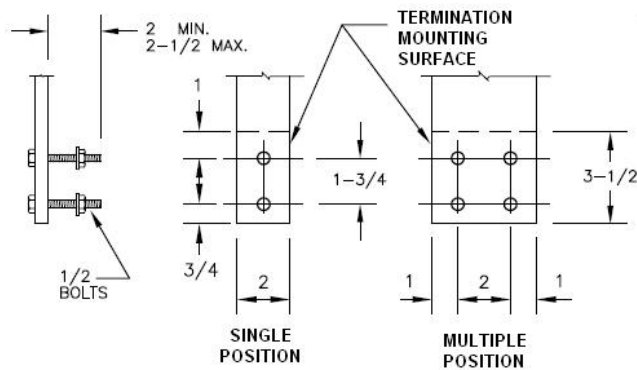

FIGURE 1
TERMINATING BOLT AND DRILLING DETAIL
OF TERMINATING FACILITIES

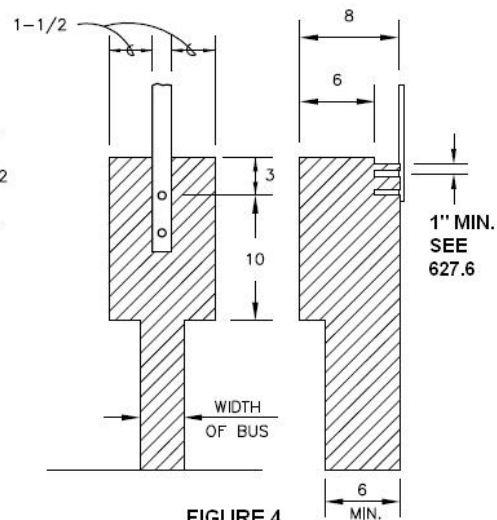

FIGURE 4
REQUIRED UNOBSTRUCTED WORKING
SPACE FOR ALL TERMINATIONS.

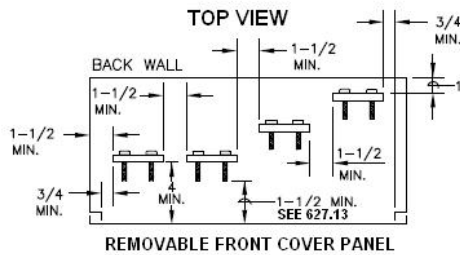

FIGURE 2
SPACING REQUIREMENTS FOR TERMINATING
FACILITIES (SIDE-BY-SIDE OR STAGGERED)

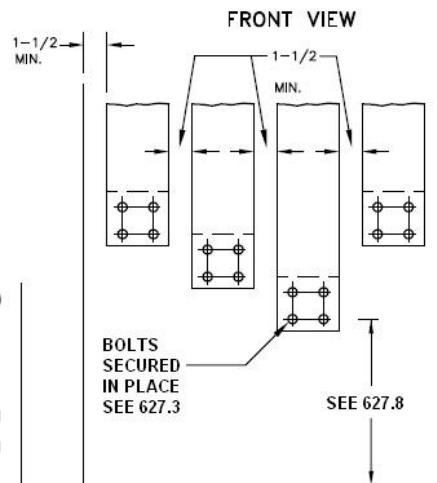

FIGURE 5
SPACING REQUIREMENTS FOR
TOP TO BOTTOM STAGGER
OF TERMINATING FACILITIES

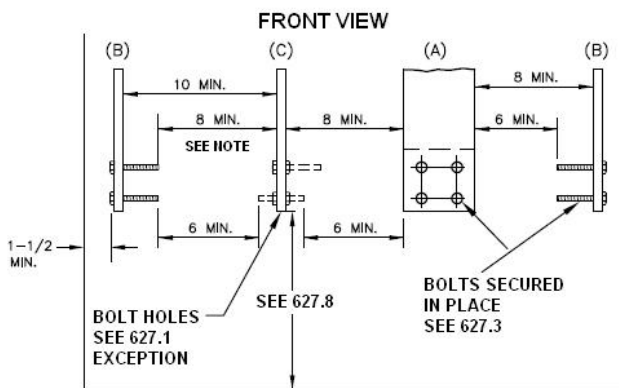

FIGURE 3
SPACING REQUIREMENTS FOR TERMINATING FACILITIES
ACCESSIBLE FROM (A) FRONT ONLY, (B) ONE SIDE ONLY,
OR (C) FROM EITHER SIDE. SEE 627.3 AND 627.4

NOTE:

4-INCH MIN. REQUIRED (ASSURE 1-INCH MIN.
CLEARANCE FROM BODY OF TERMINATING LUG
TO FRONT PANEL WHEN PRESENT

EXCEPTION: SEE 627.4 AND 627.5

ALL DIMENSIONS SHOWN ARE IN INCHES

SECTION 600 - SERVICE EQUIPMENT SPECIFICATIONS

627 Underground Service Terminating Facilities in Pull Boxes or Pull Sections

- 627.6 The clearance directly above and measured from the center of the top termination bolt may be reduced to one (1) inch to either an insulated surface or bus of the same potential.
- 627.7 No more than one (1) termination facility may be mounted along any sidewall.
- 627.8 See Sections 606, 609, and 626 for the minimum distance from the lowest bolt on the termination facility to the bottom of the termination enclosure.
- 627.9 Terminating facilities shall be secured to prevent turning or bus misalignment when the cables are installed.
- 627.10 The neutral terminating facility shall be permanently identified in clearly visible block lettering reading either "neutral" or "N".
- 627.11 For 120/240 volt, 3-phase, 4-wire, delta services, the power leg ("wild leg" measuring 208 volts to ground) shall be identified with an orange color.
- 627.12 Cross bussing of a different phase or potential installed behind or below any terminating position shall be fully insulated or barriered. Insulating barriers shall be rigid, non-flammable, rated for line voltage, resistant to puncture or damage by impact, and attached with non-conductive fasteners.
- 627.13 For switchboard pull sections, the minimum clearance from any energized part to a removable access cover panel shall be four (4) inches. This clearance may be reduced to one-and-one-half (1-1/2) inches when a safety barrier is provided by the manufacturer. The safety barrier shall be:
- a) Be constructed of a rigid insulating material, resistant to damage by impact or puncture, with a minimum thickness of one-eighth (1/8) inch.
 - b) Extend a minimum of ten (10) inches below terminating bus and extend upward to cover all energized parts that infringe into the four (4)-inch minimum clearance dimension, and be removable. Note: Brackets and associated hardware used to mount the safety barrier shall not extend into the provided access opening.
 - c) Have a sign affixed to the barrier reading "WARNING: THE BARRIER MUST BE INSTALLED BEFORE REPLACING PULL SECTION COVERS". Additional signs shall be affixed to the exterior of each section access cover reading "DO NOT REPLACE PULL SECTION COVERS UNTIL SAFETY BARRIER IN PLACE."
- 627.14 This service equipment specification is similar to EUSERC Drawing 347.

SECTION 600 - SERVICE EQUIPMENT SPECIFICATIONS

RESERVED

SECTION 700 - PAD MOUNT TRANSFORMER SPECIFICATIONS

700 ML&P Construction Standard EC11

701.1 ML&P's Construction Standard EC11 addresses pad-mount transformer clearances and the concrete mounting bases for pad-mount transformers and their clearance distances from buildings, structures, or non-utility equipment. Within the Chugach service area the following adjustments to EC11 apply:

The row one (0-100) clearances apply to pad-mounted transformers 500 kVA and smaller.

The row two (150-1000) clearances apply to 750-2000 kVA pad-mounted transformers.

The row three (1500+) clearances apply to 2500 kVA pad-mounted transformers.

Where these clearances cannot be met a deflector wall may be constructed (consult with Chugach Engineering for details). In all cases a minimum horizontal clearance between the pad-mount transformer and structures, or non-utility equipment is ten-feet in front (door/access side) and three-feet to other sides.

701.2 The installation guidelines and specifications in Construction Standard EC11 are general in nature and represent typical service applications. The Utility strongly recommends that their customers consult with the Utility's Engineering Division for specific details regarding pad-mount transformers and concrete bases for pad-mount transformers. Within the Chugach service area the maximum distance between the transformer and the service entrance is based on the size of the service and conduit installation requirements (services rated above 800A are typically limited to maximum of sixty feet and services rated above 1600A are typically limited to thirty feet).

701.3 The information presented in this section is for design purposes of customer-owned buildings, facilities, or structures.

701.4 The Utility will furnish and install pad-mount transformers in all cases involving service at secondary voltage levels. Within the Chugach service area an exception applies to Applicant construction projects only.

701.5 Under most circumstances, the Utility will furnish and install the concrete mounting bases for pad-mount transformers.

SECTION 700 - PAD MOUNT TRANSFORMER SPECIFICATIONS

700 ML&P Construction Standard EC11

REVISION: 2	DATE: 4/15/2009	SECTION SUPVR: <i>Mark Condit 5/6/09</i>
REVISED BY: MCS		OPS. MGR: <i>Robert Williams 5/11/09</i>
DRAWN BY: WHF		CHIEF ENGR: <i>[Signature]</i>

(#) = Material Item #

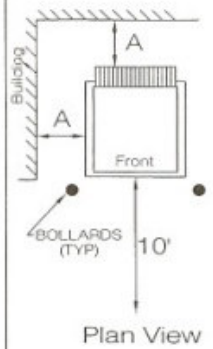

Ten feet of clearance in front of the transformer allows linemen enough space to open the doors and work the elbows with a hotstick.

See Table 1 for clearances of Pad Mounted Transformer to buildings based on transformer kVA.

If the transformer is not in an area protected from damage, ML&P will place bollards 1 foot diagonally off the corners of the transformer pad.

TABLE 1
Clearance of Pad Mounted Transformers from Buildings

XFMR SIZE (kVA)	DISTANCE A (Ft)		
	To Combustible Surfaces, or to a Door or Window	To Non-Combustible Surface	To 2 Hour Fire-rated Surfaces
0-100	10	6	3
150-1000	20	10	5
1500 +	30	20	10

NOTE: Use not less than 10 feet clearance to windows and non-fire resistant doors, but do not reduce the clearance to fire-resistant doors that may be required for exit in a emergency.

Contact the Engineering Department for which pad size you will require. Standard transformer pad sizes are:

- 48 in. x 48 in. (1φ)
- 72 in. x 72 in. (3φ)
- 94 in. x 80 in. (3φ)

Maximum distance of the transformer from the service location is 100 feet for 1φ & 60 feet for 3φ. Contact the Engineering Department for details.

Clearances must meet all municipal, state, and federal requirements.

*Information based on CLAPP RESEARCH, Inc's DANESC UPDATE VOL 10, NUMBER 4

 <p>MUNICIPALITY OF ANCHORAGE, ALASKA</p>	<p>MUNICIPAL LIGHT & POWER</p> 	<p>SHEET 1 OF 1</p> <p>PAD MOUNT TRANSFORMER CLEARANCES</p> <p>CONSTRUCTION STANDARD EC11</p>
--	--	---

APPENDICES

Meter Socket Quick Reference Guide - Self-Contained Single-Phase For all Underground Residential Services rated up to 100 amps

4-Terminal, Single-Phase, 3-Wire, 120/240 Volts, 100 Amp Rated

e.g. - Similar or equal to Cooper B-Line U1M1R (residential only) (1M1R in Chugach service area)

e.g. - Similar or equal to Cooper B-Line U1M1RP (residential only) (1M1RP in Chugach service area)

e.g. - Similar or equal to Milbank U3585-O-100 (residential only)

e.g. - Similar or equal to Siemens MM0406L1125SEC (residential only)

Notes:

1. All residential combination meter panels installed in the Utility's service area shall meet the requirements of Section 601. The products listed above were known to meet this service equipment specification at the time of publication of the Utility's 2015 Electric Service Requirements. Within the Chugach service area 100 amp rated meter panels are not approved for underground feed services (the OH version of the listed equipment is acceptable for overhead service installations outside of the MOA underground surcharge area only).
2. The Utility does not specify AIC ratings for meter panel and service disconnects. The Utility considers determination of AIC ratings of these meter panel and service disconnect devices to be the responsibility of the designer and/or installer. The Utility expects and requires the designer and/or installer of the equipment to evaluate a given electric service installation and install a disconnect device with an AIC rating appropriate for the circumstances.
3. The catalog numbers listed above typically represent the lowest available AIC rating for a particular product.

APPENDICES

Meter Socket Quick Reference Guide - Self-Contained Single-Phase

For all Underground Residential Services rated up to 200 amps

4-Terminal, Single-Phase, 3-Wire, 120/240 Volts, 200 Amp Rated

e.g. - Similar or equal to Cooper B-Line U2M2R (residential only)

e.g. - Similar or equal to Cooper B-Line U2M2RP (residential only)

e.g. - Similar or equal to Milbank U3584-O-200 (residential only)

e.g. - Similar or equal to Milbank U3585-O-2/100 (residential only) (Not approved at Chugach)

e.g. - Similar or equal to Milbank U3665-O-200 (residential only) (Not approved at Chugach)

e.g. - Similar or equal to Siemens MM0406L1200SEC (residential only)

Notes:

1. All residential combination meter panels installed in the Utility's service area shall meet the requirements of Section 601. The products listed above were known to meet this service equipment specification at the time of publication of the Utility's 2015 Electric Service Requirements. Within the Chugach service area a supplemental list of acceptable meter panels that don't meet the minimum dimensional requirements (refer to subsection 601.14) but were evaluated and approved for use is available at www.chugachelectric.com or the Chugach Engineering Division.
2. The Utility does not specify AIC ratings for meter panel and service disconnects. The Utility considers determination of AIC ratings of these meter panel and service disconnect devices to be the responsibility of the designer and/or installer. The Utility expects and requires the designer and/or installer of the equipment to evaluate a given electric service installation and install a disconnect device with an AIC rating appropriate for the circumstances.
3. The catalog numbers listed above typically represent the lowest available AIC rating for a particular product.

APPENDICES

Meter Socket Quick Reference Guide - Self-Contained Single-Phase

For all Commercial, Industrial, and Non-Residential Services

4-Terminal, Single-Phase, 3-Wire, 120/240 Volts

For 100 amp Services

e.g. - Similar or equal to Cooper B-Line Cat. No. U214MTB.

e.g. - Similar or equal to Milbank Cat. No. U214MTB.

For 200 amp Services

e.g. - Similar or equal to Cooper B-Line Cat. No. U224MTB.

e.g. - Similar or equal to Milbank Cat. No. U224MTB.

4-Terminal, Single-Phase, 3-Wire, 480 Volts

For 100 amp Services

e.g. - Similar or equal to Cooper B-Line Cat. No. U214MTB-MS-15.

e.g. - Similar or equal to Milbank Cat. No. U214MTB-48.

For 200 amp Services

e.g. - Similar or equal to Cooper B-Line Cat. No. U224MTB-MS-15.

e.g. - Similar or equal to Milbank Cat. No. U224MTB-48.

Notes:

1. All combination safety socket panels with factory installed test-block bypass facilities and service disconnects installed in the Utility's service area shall meet the requirements of Section 602. The products listed above were known to meet this service equipment specification at the time of publication of the Utility's 2015 Electric Service Requirements.
2. The Utility does not specify AIC ratings for meter panel and service disconnects. The Utility considers determination of AIC ratings of these meter panel and service disconnect devices to be the responsibility of the designer and/or installer. The Utility expects and requires the designer and/or installer of the equipment to evaluate a given electric service installation and install a disconnect device with an AIC rating appropriate for the circumstances.
3. The catalog numbers listed above typically represent the lowest available AIC rating for a particular product.

APPENDICES

Meter Socket Quick Reference Guide - Self-Contained Network For All Commercial, Industrial, and Non-Residential Services

5-Terminal, Network, 3-Wire, 120/208 Volts

For 100 amp Services

e.g. - Similar or equal to Cooper B-Line Cat. No. U214MTB with Cat. No. 50371 5th jaw kit.

e.g. - Similar or equal to Milbank Cat. No. U214MTB with Cat. No. 105J 5th jaw kit.

For 200 amp Services

e.g. - Similar or equal to Cooper B-Line Cat. No. U224MTB with Cat. No. 50371 5th jaw kit.

e.g. - Similar or equal to Milbank Cat. No. U224MTB with Cat. No. 105J 5th jaw kit.

Notes:

1. All combination safety socket panels with factory installed test-block bypass facilities and service disconnects installed in the Utility's service area shall meet the requirements of Section 602. The products listed above were known to meet this service equipment specification at the time of publication of the Utility's 2015 Electric Service Requirements.
2. The Utility does not specify AIC ratings for meter panel and service disconnects. The Utility considers determination of AIC ratings of these meter panel and service disconnect devices to be the responsibility of the designer and/or installer. The Utility expects and requires the designer and/or installer of the equipment to evaluate a given electric service installation and install a disconnect device with an AIC rating appropriate for the circumstances.
3. The catalog numbers listed above typically represent the lowest available AIC rating for a particular product.

APPENDICES

Meter Socket Quick Reference Guide - Self-Contained Three-Phase For All Commercial, Industrial, and Non-Residential Services

7-Terminal, Three-Phase, 4-Wire, 120/208 Volts

For 100 amp Services

e.g. - Similar or equal to Cooper B-Line Cat. No. U217MTB.

e.g. - Similar or equal to Milbank Cat. No. U217MTB.

For 200 amp Services

e.g. - Similar or equal to Cooper B-Line Cat. No. U227MTB.

e.g. - Similar or equal to Milbank Cat. No. U227MTB.

7-Terminal, Three-Phase, 4-Wire, 277/480 Volts

For 100 amp Services

e.g. - Similar or equal to Cooper B-Line Cat. No. U217MTBMS15.

e.g. - Similar or equal to Milbank Cat. No. U217MTB-48/22.

For 200 amp Services

e.g. - Similar or equal to Cooper B-Line Cat. No. U227MTBHMS15.

e.g. - Similar or equal to Milbank Cat. No. U227MTB-48/22.

Notes:

1. All combination safety socket panels with factory installed test-block bypass facilities and service disconnects installed in the Utility's service area shall meet the requirements of Section 602. The products listed above were known to meet this service equipment specification at the time of publication of the Utility's 2015 Electric Service Requirements.
2. The Utility does not specify AIC ratings for meter panel and service disconnects. The Utility considers determination of AIC ratings of these meter panel and service disconnect devices to be the responsibility of the designer and/or installer. The Utility expects and requires the designer and/or installer of the equipment to evaluate a given electric service installation and install a disconnect device with an AIC rating appropriate for the circumstances.
3. The catalog numbers listed above typically represent the lowest available AIC rating for a particular product.

APPENDICES

Meter Socket Quick Reference Guide - CT Rated

Single-Phase and Three-Phase

For All Services Rated 201 Amps and Above

6-Terminal, Single-Phase, 3-Wire, 120/240 Volts

For All Services Above 200 amps

e.g. - Similar or equal to Cooper B-Line Cat. No. 12146.

e.g. - Similar or equal to Milbank Cat. No. UC3436-XL.

13-Terminal, Three-Phase, 4-Wire, 120/208 Volts and 277/480 Volts

For All Services Above 200 amps

e.g. - Similar or equal to Cooper B-Line Cat. No. 121413.

e.g. - Similar or equal to Milbank Cat. No. UC3433-XL.

Note: All CT rated meter sockets installed in the Utility's service area shall meet the requirements of Section 605. The products listed above were known to meet this service equipment specification at the time of publication of the Utility's 2015 Electric Service Requirements.

APPENDICES

CT Cabinet Quick Reference Guide - Single-Phase

Single-Phase CT Service from 201 amps to 400 amps

Size: 30"W x 36"H x 11"D

e.g. - Similar or equal to Cooper B-Line Cat. No. 303611HRTCT CT enclosure with a Cat. No. 6019-HA or a Cat. No. 6019-HEL mounting base.

e.g. - Similar or equal to Erickson Cat. No. 687-1-LE CT enclosure with Cat. No. CT-1312 interior.

e.g. - Similar or equal to Milbank Cat. No. CT303611-HC CT enclosure with a Cat. No. K4797 or a Cat. No. or a Cat. No. K4729 mounting base.

Single-Phase CT Service from 401 amps to 800 amps

Size: 36"W x 36"W x 11"D

e.g. - Similar or equal to Cooper B-Line Cat. No. 363611HRTCT CT enclosure with a Cat. No. 6019-HE or a Cat. No. 6019-HEL mounting base.

e.g. - Similar or equal to Milbank Cat. No. CT363611 - HC with a Cat. No. K4797 or a Cat. No. K4729 mounting base.

Note: All wall-mounted CT cabinets and CT mounting bases installed in the Utility's service area shall meet the requirements of the appropriate service equipment specifications as set forth in this book. The products listed above were known to meet their respective service equipment specification at the time of publication of the Utility's 2015 Electric Service Requirements.

APPENDICES

CT Cabinet Quick Reference Guide - Three-Phase

Three-Phase CT Service from 201 amps to 600 amps

Size: 36"W x 48"H x 11"D

e.g. - Similar or equal to Cooper B-Line Cat. No. 364811HRTCT CT enclosure with a Cat. No. 6067-HA or a Cat. No. 6067-HEEL mounting base for 400 amp rated services, and a Cat. No. 6067-HEE or a 6067-HEEL mounting base for 600 amp rated services.

e.g. - Similar or equal to Milbank Cat. No. CT364811-HC CT enclosure with a Cat. No. K4798 or a Cat. No. K4722 mounting base for 400 amp and 600 amp rated services.

Three-Phase CT Service from 601 amps to 800 amps

Size: 48"W x 48"H x 14"D

e.g. - Similar or equal to Cooper B-Line Cat. No. 484814DD-HRTCT CT enclosure with a Cat. No. 6067-HEE or a Cat. No. 6067-HEEL mounting base.

e.g. - Similar or equal to Milbank Cat. No. CT484814-HC CT enclosure with a Cat. No. K4798 or a Cat. No. K4722 mounting base.

Three-Phase CT Service from 801 amps to 1200 amps

Size: 50"W x 60"H x 14"D with hinged door

e.g. - Similar or equal to Erickson Cat. No. CT-124-MLP-SG CT enclosure with Cat. No. CT-1327 interior.

Three-Phase CT Service from 1201 amps to 1600 amps

Size: 60"W x 60"H x 14"D with hinged door

e.g. - Similar or equal to Erickson Cat. No. CT-164-MLP-SG CT enclosure with Cat. No. CT-1335 interior.

Three-Phase CT Service from 1601 amps to 2000 amps

Size: 64"W x 64"H x 14"D with hinged door

e.g. - Similar or equal to Erickson Cat. No. CT-204-MLP-SG CT enclosure with Cat. No. CT-1338 interior.

Note: All CT cabinets and CT mounting bases installed in the Utility's service area shall meet the requirements of the appropriate service equipment specifications as set forth in this book. The products listed above were known to meet their respective service equipment specification at the time of publication of the Utility's 2015 Electric Service Requirements.

APPENDICES

Glossary

AC: The abbreviation for alternating current.

ACCESS, ACCESSIBLE: “Access” means capability of being reached quickly for operating, reading, repairing, removing, testing, inspecting, or installing meters, transformers, switches, conductors, electrical enclosures, and related equipment without requiring those for whom access is required to climb over or remove obstacles, to unlock doors, to dismantle fences or gates, and so forth. Accessible equipment is not guarded by architectural enhancements, dogs, elevation, locks, parked vehicles, structures, or other impediments.

ACCESS OPENING: The minimum opening of a pull section or termination enclosure required for utility work access. This opening is measured from the edge of flange to the edge of flange; not from sidewall to sidewall.

AIC: As used in this book is defined as the Ampere Interrupting Capacity (AIC), sometimes referred to as the Ampere Interrupting Rating (AIR) of meter disconnects, service disconnects, main service disconnects, and other service entrance equipment. AIC ratings are sometimes applied to the mechanical bracing of conductors or bus of service entrance equipment such as CT mounting bases or switchboard service sections. Also see INTERRUPTING RATING.

AEIC: Association of Edison Illuminating Companies.

AMPACITY: The current expressed in amperes that an electric conductor can carry continuously under specified conditions of use without exceeding its temperature rating.

AMPERE (Amp): The practical unit of electric current. One (1) ampere is the current caused to flow through a resistance of one (1) ohm by one (1) volt.

ANSI: American National Standards Institute.

APPROVED: As used in these requirements, the term “approved” means authorized, sanctioned, permitted, or specified by the Utility. In most cases, the approval will be in written or published form.

AUTOMATIC BYPASS: A device within a meter socket that automatically operates upon removal of the meter from the socket allowing current to flow from the Utility’s (line-side) socket clips to the customer’s (load-side) socket clips with the meter removed from the socket.

AWG: American Wire Gage, a term used to measure wire size.

BILLING METERING: Electricity meters, recorders and associated devices used by the Utility to measure electric energy consumed by the customer as necessary to implement a given rate schedule.

BONDING (BONDED): The permanent joining of metallic parts to form an electrically conductive path which will assure electrical continuity and the capacity to conduct safely any current likely to be imposed.

BREAKER: Customer’s circuit breaker. See CIRCUIT BREAKER.

BUS, LAMINATED: More than one bus bar per phase, connected in parallel.

BUS, LIVE: Bus bars which are normally energized.

BUS, REMOVABLE LINK: Used in a CT compartment to link the line and load bus together. This removable section of bus is designed to allow the installation or removal of CTs.

APPENDICES

Glossary

BUS STUBS: The part of a bus bar reserved for the termination of conductors.

BUSHINGS: Plastic or nylon rings that attach to the ends of conduit to protect the electrical cable from sharp edges.

BYPASS: A device which shunts current around the meter socket so the meter can be removed without interrupting service to the customer. Also see TEST-BLOCK BYPASS.

CAPTIVE SCREWS: Screws used to attach removable metering panel covers on switchboards or enclosures and designed to stay attached to the panel cover when the panel cover is removed.

CHUGACH: Chugach Electric Association.

CIRCUIT BREAKER: A device designed to open and close a circuit by non-automatic means and to open the circuit automatically on a predetermined over-current without damage to itself when properly applied within its rating.

CLEARANCE, BARREL OF PROXIMITY: The clearance described by an imaginary barrel around a termination facility measured from the sides, top, bottom, front, and back of the terminating surface to a grounded surface or other terminating facility. Includes the studs or bolts when in place.

CLEARANCE, RADIAL: The clearance required around a termination facility measured from the sides, top and bottom of the termination surface area. See CLEARANCE, BARREL OF PROXIMITY.

COMMERCIAL SERVICE PEDESTAL: A free standing meter enclosure, typically used for commercial service applications such as street lighting load centers or traffic signal load centers, usually including a customer distribution panel, lighting contactors, photo cells, etc. Commercial service pedestals are mounted by bolting to a suitable concrete base. Also see METER PEDESTAL.

CONDUCTORS, LINE-SIDE (SUPPLY-SIDE): See CONDUCTORS, UN-METERED.

CONDUCTORS, LOAD-SIDE: See CONDUCTORS, METERED.

CONDUCTORS, METERED: Conductors transmitting electrical energy that has been previously recorded by the Utility's billing meter.

CONDUCTORS, UN-METERED: Conductors transmitting electrical energy that has **not** been recorded by the Utility's billing meter.

CONDUIT: A listed or approved pipe with a smooth interior surface to permit easy drawing in of electrical conductors.

CONTINUOUS LOAD: A load where the maximum current is expected to continue for three hours or more.

CONNECTOR, PRESSURE: A device that establishes a connection between two or more conductors or between one or more conductors and a terminal by means of mechanical pressure and without the use of solder.

CORFLO: A flexible duct made of synthetic material used as a conduit for electric cables. Corflo is used by the Utility to install underground service temporarily above ground. The Utility limits the use of corflo in above ground applications to secondary (less than 600 volts) service applications (corflo in above ground 480 volt applications is limited to restricted access areas that are not accessible to the public).

APPENDICES

Glossary

CT: An acronym for Current Transformer. The term CT and the phrase “Current Transformer” are synonymous terms. See CURRENT TRANSFORMER.

CT POLARITY: The instantaneous direction of current flow in the primary and secondary windings of the CT. Polarity markings are so placed that when the primary current is flowing into the marked primary terminal H1, the secondary current is flowing out of the marked secondary terminal X1. These markings enable the secondary of the CT to be connected to the meter with the proper phase relationships.

CT RATED METER: An electricity meter used in conjunction with current transformers to accurately measure and register all the electrical energy consumed in the circuit to which it is connected.

CURRENT: See AMPERE.

CURRENT TRANSFORMER: An instrument transformer designed for the measurement of current. It is used to reduce primary current by a known ratio to within the range of a transformer rated kilowatt-hour meter. Current transformers are often referred to by the acronym CT.

CUSTOMER: Any person, persons, corporation, etc. or their designated representative, for whom the electric service and meter installation is provided.

DISCONNECT DEVICE: A device whereby the conductors of a circuit can be disconnected from their source of supply (IEEE 100-1984).

DISCONNECTING MEANS: A device or group of devices or other means by which the conductors of a circuit can be disconnected from their source of supply.

DRIP LOOP: A downward loop in the customer’s conductors adjacent to the Utility’s conductors to prevent water from entering the service mast at the weatherhead.

EASEMENT: Refer to definition in Section 207.

EI: Edison Electric Institute.

ELECTRODE: A solid electric conductor through which an electric current enters or leaves. As used in this book, the term refers to a grounding electrode. See GROUNDING ELECTRODE.

ENCLOSURE: Box-like structure designed to enclose and protect utility service conductors or equipment.

EUSERC: Electric Utility Service Equipment Requirements Committee (EUSERC), an organization composed of utility representatives from the western region of the United States that works to promote uniform electric service requirements and the design and engineering of metering and service equipment.

FILLER PANEL: The panel used on a switchboard in conjunction with a meter panel to effect a cover over the total instrument transformer enclosure opening.

FREQUENCY: The number of cycles occurring in a given interval of time (usually one second) in an electric current. Frequency is commonly expressed in hertz.

GIS: An acronym for Gas Insulated Switchgear (GIS). As used in this book, the term GIS refers to medium-voltage switchgear used on distribution system voltages from 4,160 volts to 34,500 volts.

APPENDICES

Glossary

GRANDFATHER CLAUSE: A clause in which a rule or requirement which creates an exemption from a more recent rule or requirement or where an old rule or requirement continues to apply to some existing situations while a new rule or requirement applies to all future situations. See Subsection 301.13.

GROUND: A conducting connection, whether intentional or accidental, between an electric circuit or equipment and earth.

GROUNDED: As used in this book, it means intentionally connected to earth through a ground connection or connections of sufficiently low impedance and having sufficient current-carrying capacity to prevent the buildup of voltages that may result in undue hazards to connected equipment or to persons.

GROUNDING CONDUCTOR: A conductor used to connect any equipment device, or wiring system, with a grounding electrode or electrodes.

GROUNDING ELECTRODE: A conductor embedded in the earth, used for maintaining ground potential on conductors connected to it and for dissipating current conducted to it into the earth.

GROUNDING LUG: A lug designed for terminating the customer's grounding wire.

GUYING: Cables or braces used to relieve the strain of overhead conductors on masts and poles.

HANDLES, LIFTING: Handles attached to meter and service equipment panels to aid in the panel removal/replacement, and open/close operation. They are to be non-folding grasp type designed to provide full secure attachment and the ability to withstand stress of a seventy-five (75) pound load.

HERTZ (Hz): The term denoting cycles per second. See FREQUENCY.

HIGH LEG: In a three-phase, 4-wire delta service, the phase conductor having a higher voltage to ground than the other two phases is known as the "high leg". It is sometimes referred to as the "wild leg".

IEEE: Institute of Electrical and Electronics Engineers.

IMC: Intermediate metallic conduit.

INSTRUMENT TRANSFORMER: A transformer that reproduces in its secondary circuit a definite and known ratio of the current or voltage of its primary circuit, with the phase relationship substantially preserved.

INSTRUMENT TRANSFORMER COMPARTMENT: See TRANSFORMER COMPARTMENT.

INSULATING BARRIER: A barrier of non-conductive material within an enclosure, compartment, switchboard, etc., that effectively prevents electrical energy within conductors or bus bars from accidentally contacting ground or neutral or contacting phase-to-phase in an uncontrolled manner.

INTERRUPTING RATING: As defined by the NEC, interrupting rating is the highest current at rated voltage that a device is intended to interrupt under standard test conditions

ISOLATING BARRIER: A partition of either conductive or non-conductive material used to mechanically isolate energized equipment from outside elements and/or to mechanically isolate compartments or sections from other integral sections or compartments of the enclosure.

LINE-SIDE CONDUCTOR: A service conductor delivering electrical power to the customer which has not been recorded by the Utility's meter.

APPENDICES

Glossary

LOAD-SIDE CONDUCTOR: Any conductor delivering electrical power to the customer which has been recorded by the Utility's meter.

LOCKABLE: Accepting a padlock with a shackle diameter of five-sixteenths (5/16) inch.

LUGS: Used to terminate cable conductors on termination facilities.

LUGS, RANGE-TAKING: Lug designed to accept more than one size cable within a specified range.

MAIN SERVICE DISCONNECT: A circuit breaker, fused switch, or other approved disconnecting means installed on the supply (line) side of an installation of seven (7) or more meter sockets.

METER DISCONNECT: A circuit breaker, fused switch, or other approved service disconnecting means with overcurrent protection that controls all of, and only the energy registered by its related meter.

METER HEIGHT: Meter height is the distance measured from the center axis of the installed meter to the standing surface immediately in front of the meter.

METER JAW: A spring-loaded receptacle inside a meter socket which captures the terminals (blades) of a meter and connects the meter terminals to the service conductors.

METER PANEL: Panel used exclusively for mounting meter sockets and associated equipment.

METER PEDESTAL: Free standing meter enclosure, typically used for commercial applications. Installed by bolting to a concrete base. Also see COMMERCIAL SERVICE PEDESTAL.

METER SEQUENCE: The sequential relation between the service switch and the billing meter in a series arrangement. The term NEW SEQUENCE means a meter-switch-fuse sequence. OLD SEQUENCE means a switch-fuse-meter sequence.

METER SOCKET: The mounting device consisting of meter jaws, connectors, and enclosure for accommodating socket-type meters.

ML&P: Municipal Light & Power.

MOA: Municipality of Anchorage.

MOA INSPECTION AREA: The entire Anchorage Bowl except portions of the Upper Hillside that include; Stuckagain Heights, Glen Alps, Bear Valley and Potter Heights.

MULTIPLE METERING: Prefabricated service entrance equipment consisting of a service termination section and two (2) or more meter sockets.

NEC: The most recent State adopted publication of the National Electrical Code.

NEMA: National Electrical Manufacturers Association

NESC: The most recent State adopted publication of the National Electrical Safety Code

NET METERING: Metering for the receipt and delivery of electricity between a producer and the Utility pursuant to RCA rules. Over a given time frame (typically a month) the difference between these two values yields either NET consumption or surplus. See Section 214.

APPENDICES

Glossary

NETWORK METERING: A single-phase load served by a three-phase 4-wire wye connected power source using a 2-element, 3-wire meter in Form 12S configuration.

NEUTRAL: The grounded conductor in a single-phase 3-wire, or three-phase, 4-wire system.

NON-TRACKING: Insulating material with dielectric characteristics sufficient to resist carbonizing or deterioration when subject to rated voltage and design conditions.

OEM: For the purposes of this book, OEM refers to the Original Equipment Manufacturer (OEM).

PLUMB: In this case referring to the meter socket enclosure. To have the sides and front of the meter socket enclosure perfectly vertical from both the front and side views.

POINT OF COMMON COUPLING: The transfer point for electricity between the electrical conductors of the Utility and the electrical conductors of the customer.

POINT OF INTERCONNECTION: The point where the load or customer's conductors or those of their respective agents meet the Utility's electric power system (point of ownership change).

POLARITY, CT: See CT POLARITY.

POTENTIAL TRANSFORMER (PT): See VOLTAGE TRANSFORMER (VT).

POWER FACTOR: The ratio of active power to apparent power (watts divided by volt-amperes). Power factor has no units; it is commonly expressed as a percentage. For example, if active power is 96 kW and apparent power is 100 KVA, the power factor is 96%.

PRIMARY: Service voltage greater than 600 volts.

PRIMARY METERING CABINET: A high voltage enclosure designed to house instrument transformers and to terminate high voltage line side service conductors and high voltage load-side conductors.

PULL BOX: An enclosure used for pulling service conductors.

PULL SECTION: The compartment in a customer's switchboard where the Utility's service conductors are terminated.

RACEWAY: An enclosed channel designed expressly for holding wire, cables or bus bars. If designated for line-side conductors, it shall be sealable. The intermixing of line-side and load-side conductors in the same raceway is **not** permitted.

RCA: Regulatory Commission of Alaska.

RETURN FLANGE: A flange inside and around an opening. Typically used around pull box or pull section openings. The flange surface is in the plane of, and used for cover attachment.

RISER CONDUIT: That section of conduit provided by the customer that interfaces with the conduit of the Utility's service lateral to the customer's service entrance equipment. The riser conduit includes the section that transitions from the horizontal to the vertical. See Section 520.

RMC: Rigid metal conduit.

APPENDICES

Glossary

SAFETY SOCKET: Meter socket with test-block bypass facilities.

SEALABLE: Normally, the provisions for the installation of the Utility's wire security seals. Other devices such as padlocks may be specified for sealing. See Section 305.

SECONDARY: Service voltage less than 600 volts.

SELF-CONTAINED METER: A meter that carries the entire load current and is energized at line voltage.

SERVICE: Electric service from the Utility's electric distribution system to the electrical equipment of the customer's facilities.

SERVICE DISCONNECT: A circuit breaker, fused switch, or other approved disconnecting means by which the service conductors can be disconnected from the utility source of supply. The term "Service Disconnect" can be used to describe a disconnect device installed on the supply (line) side of more than six meters also referred to as a main service disconnect. The term "Service Disconnect" can also be used to describe a meter disconnect which controls all of, and only the energy registered by its related meter. See MAIN SERVICE DISCONNECT and see METER DISCONNECT.

SERVICE EQUIPMENT: As used in this book, the term "service equipment" refers to meter sockets, meter socket enclosures, meter panels, multi-meter panels, service conductor termination compartments, pull boxes for service conductors, pull sections for service conductors, CT cabinets, CT compartments of switchboards, bus spacers, service disconnects, meter disconnects, main service disconnects, grounding electrodes, grounding electrode conductors, and any other equipment or enclosures related to the supply and metering of electric service from the Utility's system to a customer's premises. For the purposes of this book, the terms "service equipment" and "service entrance equipment" are synonymous terms.

SHUNT TRIP: As used in this book, the term refers to the equipment required to remotely control a circuit breaker or other similar service disconnect device. See Subsection 306.7.

SUB-METERING: A watt-hour meter or meters installed downstream from the Utility's billing meter by a customer. See Section 213.

SWITCH: A device for making, breaking, or changing the connections in an electric circuit.

SWITCHBOARD: A large single panel, frame, or assembly of panels on or in which are mounted switches, over-current and other protective devices, busses, instrument transformers and meters. Switchboards used in the Utility's service area shall be "front only accessible".

SWITCHBOARD SERVICE SECTION: That part of a switchboard provided specifically for termination of the Utility's service conductors and CTs, when required. The revenue meters, bypass facilities, and service switch or breaker may also be located in this area. However, the metered conductors may pass through this section only from the point of attachment with the CTs or the load-side meter terminals to the service switch or breaker. The CT compartment of this section **shall be isolated** from the customer's switch or breakers.

SWITCHBOARD, STANDARD: An electrical switchboard of minimum dimensions of height, width, and depth with hinged meter panels, and standard size CT compartment when required.

TERMINATING FACILITIES: Bolt-type pads, bus stubs, or range-taking lugs provided by the customer for the sole purpose of attaching the utility's unmetered service conductors to the customer's service equipment.

APPENDICES

Glossary

TEST-BLOCK BYPASS: An assembly used in conjunction with a self-contained meter socket designed to allow the utility to de-energize the meter socket without disconnecting electric service to the customer.

TEST SWITCH: An arrangement of small knife switches connected in the secondary current transformer circuit between the instrument transformers and associated meters and metering devices. The test switch is used by the Utility to isolate the metering from the instrument transformers. Also referred to as a meter test switch.

TEST SWITCH PERCH: A bracket designed for the mounting of the Utility's meter test switch.

TRANSFORMER COMPARTMENT: A designated area provided within a switchboard for the Utility's exclusive use to install CTs.

TYPICAL: Exhibiting the traits or characteristics peculiar to a class or group, a representative example.

UTILITY: Municipal Light & Power and Chugach Electric Association.

VISIBLE OPEN: As used in this book, the term refers to an electrical disconnect device where an actual physical break in the electric circuit is observable without resorting to extraordinary means.

VOLT: The practical unit of electromotive force, or potential difference. One (1) volt will cause one (1) ampere to flow when impressed across a one (1) ohm resistor.

VOLTAGE TRANSFORMER (VT): An instrument transformer designed for the measurement of voltage. It is used to reduce primary voltage by a known ratio to within the range of a transformer rated kilowatt-hour meter.

WATT: The practical unit of active power which is defined as the rate at which energy is delivered to a circuit. It is the power expended when a current of one (1) ampere flows through a resistance of one (1) ohm. A watt represents a unit of real electric power as contrasted with a volt-ampere which represents a unit of apparent power.

WATTHOUR: The practical unit of electric energy which is expended in one (1) hour when the average power during the hour is one (1) watt.

WATTHOUR METER, CT RATED: An electricity meter used in conjunction with current transformers to accurately measure and register all the electrical energy consumed in the circuit to which it is connected. The unit of measurement is the kilowatt-hour.

WATTHOUR METER, SELF-CONTAINED: An electricity meter that measures and registers all the electrical energy consumed in the circuit in which it is connected and does not require instrument transformers. The unit of measurement is the kilowatt-hour.

UL: Underwriters Laboratory.

APPENDICES

EUSERC/ELECTRIC SERVICE REQUIREMENTS DRAWING CROSS REFERENCE

EUSERC Drawing Numbers similar to ESR Service Equipment Specifications:

EUSERC 301.....	Drawing 601.....	Drawing 601.....	EUSERC 301
EUSERC 304.....	Drawing 602.....	Drawing 602.....	EUSERC 304
EUSERC 305A.....	Drawing 602.....	Drawing 602.....	EUSERC 305A
EUSERC 306.....	Drawing 603.....	Drawing 603.....	EUSERC 306
EUSERC 308.....	Drawing 604.....	Drawing 604.....	EUSERC 308
EUSERC 315.....	Drawing 608.....	Drawing 605.....	EUSERC 339
EUSERC 316.....	Drawing 614.....	Drawing 606.....	EUSERC 342
EUSERC 320.....	Drawing 620.....	Drawing 607.....	EUSERC 353
EUSERC 322.....	Drawing 621.....	Drawing 608.....	EUSERC 315
EUSERC 324.....	Drawing 622.....	Drawing 609.....	EUSERC 343
EUSERC 325.....	Drawing 616.....	Drawing 610.....	EUSERC 328A
EUSERC 326.....	Drawing 617.....	Drawing 611.....	EUSERC 328B
EUSERC 327.....	Drawing 625.....	Drawing 612.....	EUSERC 329A
EUSERC 328A.....	Drawing 610.....	Drawing 613.....	EUSERC 329B
EUSERC 328B.....	Drawing 611.....	Drawing 614.....	EUSERC 316
EUSERC 329A.....	Drawing 612.....	Drawing 615.....	NA
EUSERC 329B.....	Drawing 613.....	Drawing 616.....	EUSERC 325
EUSERC 330.....	Drawing 623.....	Drawing 617.....	EUSERC 326
EUSERC 331.....	Drawing 624.....	Drawing 618.....	EUSERC 332
EUSERC 332.....	Drawing 618.....	Drawing 619.....	EUSERC 354
EUSERC 339.....	Drawing 605.....	Drawing 620.....	EUSERC 320
EUSERC 342.....	Drawing 606.....	Drawing 621.....	EUSERC 322
EUSERC 343.....	Drawing 609.....	Drawing 622.....	EUSERC 324
EUSERC 345.....	Drawing 626.....	Drawing 623.....	EUSERC 330
EUSERC 347.....	Drawing 627.....	Drawing 624.....	EUSERC 331
EUSERC 353.....	Drawing 607.....	Drawing 625.....	EUSERC 327
EUSERC 354.....	Drawing 619.....	Drawing 626.....	EUSERC 345
.....	Drawing 627.....	EUSERC 347

Index

A	
Access, Accessible.....	10, 15, 16, 27, 210
Ampacity Ratings, General.....	20
AIC Ratings.....	31, 202, 203, 204, 207, 210
Application for Service.....	4
Automatic Transfer Switch.....	12, 120
Approved.....	14, 18, 210
B	
Bonded, Bonding.....	23, 37, 210
Breaker.....	25, 31, 210
Bypass.....	19, 20, 32, 134, 138, 211
C	
Changes in Requirements.....	1
Character of Service.....	3
Clearance, Meters.....	19, 130
Clearance, Overhead Conductors.....	64
Clearance, Transformers.....	10, 184
Codes and Ordinances.....	1
Combination Disconnect Device and Terminating Enclosure.....	152
Commercial Hinged-Top Service Pedestal.....	74, 132
Complaints, Service.....	2
Conduit, Rigid Metal.....	126
Connection, Service Conductor.....	9
Coordination Responsibilities.....	2
Corflo.....	6, 7
CT Cabinet Dimensions.....	104, 108, 114, 168, 172
CT Compartment Dimensions.....	183, 185, 187
CT Metering Installation Guidelines and Specifications.....	102, 106, 110, 116
CT Mounting Base.....	156, 160, 162, 166
CT Polarity.....	40, 44, 212
CT Rated Metering Requirements, General.....	37
CT Supports (Mounting Provisions).....	188, 190
Customer Facilities.....	8
Customer Sub-Metering for Resale of Electricity.....	13
D	
Delivery, Point of.....	8
Disconnection.....	2
Disconnect Device Requirements.....	25
E	
Easements.....	8
Electrical Generators and Transfer Equipment.....	11, 120
Electric Service Extensions to Permanent Facilities.....	6
Electric Service Extensions to Temporary Facilities.....	7
F	
Fire Alarm and Fire Pump Equipment.....	48
G	
Gas Service Equipment.....	17
Generators.....	11, 120
GIS.....	30, 212
Grandfather Clause.....	15, 213
Grounding and Bonding Requirements.....	23

Index

H

Height, Bussed Gutters.....	88
Height, CT Cabinets	38, 39, 104, 108, 112
Height, Meter Sockets	19, 36, 38, 39, 45, 132, 136, 144, 146, 160
High Voltage (Primary) Metering Requirements, General	46
Hinged Meter Panel.....	178

I

Identification of Meter Sockets.....	36, 37, 78, 84, 88, 92, 96,100
Inspection Requirements	50
Interconnection and NET Metering.....	13

L

Labeling of Meter Sockets	36, 37, 78, 84, 88, 92, 96,100
Line Extension.....	4
Load Control and Pulse Metering.....	47
Location, Meters and Service Equipment	15
Locking Requirements	24, 25, 26, 29, 30

M

Main Service Disconnect	25, 26, 27, 28
Meter Access Requirements.....	15
Meter Disconnects.....	25, 27, 28, 31, 33, 37, 42
Meter Location.....	15
Meter Sequence	18
Meter Socket Height.....	19, 36, 37, 38, 45, 132, 136, 144, 146
Meter Socket Side Clearance Requirements.....	19, 130
Metering and Service Equipment Location	15
Metering and Service Equipment Requirements, General	18
Multiple Metering Requirements, General	33
Multiple Metering, Residential, 6-Meter Maximum	78
Multiple Metering, Commercial, 6-Meter Maximum.....	82, 86
Multiple Metering, Self-Contained and CT Rated.....	90
Multiple Metering, Switchboard Style, 7-Meter Minimum	94
Multiple Metering, Wall-Mounted Style, 7-Meter Minimum	98

N

National Electric Code	1
Natural Gas Service Clearance Requirements	17
NEC	1, 214
Network Metering	3, 33, 205, 215
NET Metering	13, 214

O

Overhead Services to Buildings or Structures	52
Overhead Services Attached to Poles.....	56
Overhead Temporary Construction Service.....	60
Overhead Conductor Clearances.....	64

P

Pad Mount Transformer Clearances	10, 200
Point of Delivery	8
Primary Metering.....	46
Pulse Metering	47
Purpose.....	1

R

Residential Meter Socket Requirements	31, 32, 132
Right of Way.....	8, 10
Rigid Metal Conduit	126

Index

S

Safety Sockets	32, 134
Scope.....	14
Sealing and Locking Requirements.....	24
Self-Contained Metering Requirements, General	31
Service Area.....	iv,v,1
Service Complaints.....	2
Service Conductor Connection	9
Service and Meter Disconnect Requirements.....	25
Service Equipment Definition.....	18, 216
Service Extensions, Permanent	6
Service Extensions, Temporary	7
Service Facilities on Customer's Premises.....	10
Service Feasibility.....	5
Service Riser Conduit Requirements	126
Side Clearance Requirements	19, 130
Single-Phase CT Service, Wall-Mounted, 201 Amps to 800 Amps	102
Sub-Metering for Resale of Electricity	13
Shunt Trip.....	28
Switchboard Service Sections, 201 Amps to 4,000 Amps.....	116
Switchboard Service Section Requirements, General	42

T

Tampering.....	10
Temporary Service Extensions	7
Temporary Service Installation Guidelines and Specifications	60, 66
Test-block Bypass Facilities.....	19, 20, 32, 35, 134, 138, 144
Transfer Switches.....	11, 120
Transformer Clearances	10, 200
Types of Service.....	3

U

Underground Ordinance	3, 6
Underground Service, Wall-Mounted, Up to 200 Amps.....	68
Underground Service, Post-Mounted	70
Underground Temporary Construction Service.....	66
Undesirable Service Characteristics.....	11
Unusual Conditions	48

V

Visible Open.....	30, 217
-------------------	---------

W

Working Space and Clearance Requirements.....	130
---	-----

RESERVED

The mission of ML&P is to provide service with competitive, safe, reliable energy.

The mission of Chugach Electric is through superior service, safely provide reliable and competitively priced energy.

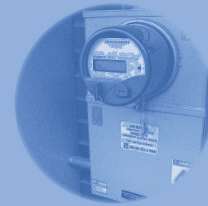
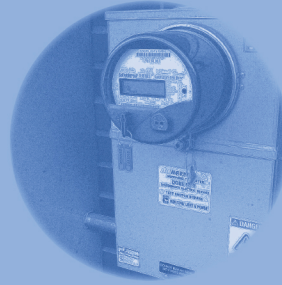
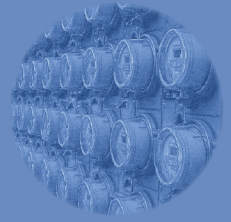
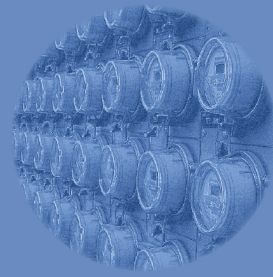
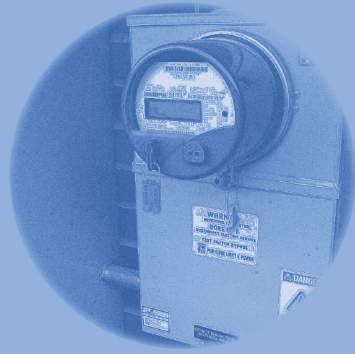

Chugach Electric
5601 Electron Drive
Anchorage, AK 99518
907-563-7494
www.chugachelectric.com

Municipal Light & Power
1200 East 1st Avenue
Anchorage, AK 99501
907-279-7671
www.mlandp.com